

Maxi-Lift Inc.

ELEVATOR BUCKETS & BOLTS

Complete Product Catalog



AGRICULTURAL INDUSTRIAL

800.527.0657



MAXILIFT.COM

2013

MAXI-LIFT® FAMILY HISTORY

Our Commitment to You



Our Promise to You

A lot of things can happen over 40 plus years. For Maxi-Lift, it has been an amazing metamorphosis, in our business, our products and our services. We started out with a few plastic elevator buckets and a tireless work ethic, and this little company has grown into a world leader in elevator components. Through all of this growth, our core values have remained. Commitment to Innovation, Quality and Integrity drive our business every day.

- **Innovation** - Product development to make our customers' equipment more efficient, more reliable and safer.
- **Quality** - Our manufacturing procedures and operations are designed to give our customers reassurance that they get our best effort and product every time.
- **Integrity** - Above all else, the consistent integrity in our actions, values and principles keep us true to our core values, never accepting anything less.

We work hard every day to continue improving, growing and serving. Our promise is to keep these values at the center of everything we do, for you, and for ourselves.

Sincerely,

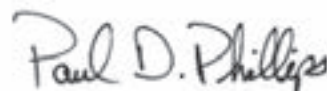

Paul Phillips
President

MAXI-LIFT CATALOG INDEX

Products, Accessories & Engineering Information

SECTION I - OVERVIEW

| | |
|---------------------------|-----|
| LETTER FROM OUR PRESIDENT | 2 |
| MAXI-LIFT: GLOBAL LEADERS | 4-5 |
| PRODUCT LINES | 6-7 |
| HOW TO ORDER | 8 |

SECTION II - AGRICULTURAL ELEVATOR BUCKETS

| | |
|------------------------------------|-------|
| NEW PRODUCTS | 10-11 |
| TIGER-TUFF MAXIMUM DUTY | 12-19 |
| TIGER-CC MAXIMUM DUTY | 20-25 |
| HD-MAX HEAVY DUTY | 26-31 |
| CC-MAX HEAVY DUTY | 32-37 |
| DURA-BUKET STANDARD DUTY | 38-42 |
| STANDARD DUTY STEEL, STEEL DIGGERS | 43-45 |
| 3 FOR FREE FORM | 46 |

SECTION III - INDUSTRIAL ELEVATOR BUCKETS

| | |
|--|-------|
| MAXI-TUFF AA | 48-54 |
| MAXI-TUFF MF | 55-57 |
| TIGER-TUFF INDUSTRIAL | 58-63 |
| TIGER-CC INDUSTRIAL | 64-69 |
| DI-MAX DUCTILE IRON | 70-73 |
| STEEL DIGGER AA | 74 |
| WELDED STEEL AA, MF, AC, ACS, SC, LF, HF, CUSTOM | 75-82 |

SECTION IV - PARTS & ACCESSORIES

| | |
|--|-------|
| ELEVATOR BOLTS, NUTS, WASHERS, SPACERS | 84-85 |
| TITAN BELT SPLICE | 86-87 |
| MAXI-SPLICE FASTENING SYSTEM | 88-89 |
| SCREW CONVEYOR HANGER BEARINGS | 90 |
| UHMW SHEETING | 91 |
| DRAG FLIGHTS | 92-93 |
| MIGHTY-MAX FENCE FEEDER | 94 |

SECTION V - ENGINEERING INFORMATION

| | |
|-------------------------------|---------|
| HOW TO CALCULATE CAPACITY | 96 |
| BUCKET SPEED CHARTS | 97-99 |
| PUNCHING CHARTS | 100-103 |
| BUCKET ELEVATOR QUESTIONNAIRE | 104-105 |
| BULK MATERIAL DENSITY CHARTS | 106-109 |
| CONTACT INFO | 110 |
| SOUTHWEST AGRI-PLASTICS, INC. | 111 |



Maxi-lift Inc.®

At Maxi-Lift, we are defined by our strong brands, innovative products, technical expertise and friendly customer service. These are just a few of the many reasons our customers consider us the global leaders in plastic and metal elevator buckets.

GLOBAL LEADERS

Maxi-Lift manufactures and sells elevator buckets to customers in over 70 countries, and our client list continues to grow. We have stocking distributors throughout the world and our products fulfill the diverse needs of our clients. Our products are used on rice farms in Guyana, elevator upgrades in Romania, new feed plants in China, large river and port projects in North America, cement facilities in Mexico, and the largest soybean processing plants in Argentina. The Maxi-Lift name is known internationally for outstanding products and services. This is why we are proud to call ourselves the global leaders in the industry.

BUCKETS WORTHY OF THE MAXI-LIFT NAME

Our customers demand the toughest, longest lasting buckets, which is why we manufacture the strongest brand names in the world, **TIGER-TUFF, TIGER-CC, MAXI-TUFF, CC-MAX, and HD-MAX**. It's no surprise that the largest agricultural and industrial Fortune 500 companies ask for Maxi-Lift buckets by name.

NOT ALL BUCKETS ARE CREATED EQUALLY

With the last 15 years spent developing and introducing five new product lines of elevator buckets, we can say that we manufacture the toughest buckets in the world-buckets that will outlast, out perform and carry more than our competitors. Maxi-Lift makes **over 700 different bucket sizes, shapes and materials**, designed to give our customers **longer life, better reliability, and a lower total cost of ownership**.



Take a close look; while many buckets look similar, the fact remains that only Maxi-Lift gives you the reliability, performance, and value that you can measure. When looking for elevator buckets, don't be fooled by imitations. Our products consistently demonstrate the long-term value that is associated with the Maxi-Lift name.

ENGINEERING, UPGRADING, AND TROUBLESHOOTING IS OUR BUSINESS

Maxi-Lift's free technical service can help you, no matter what type of problem you may be facing. We can help you design, analyze, evaluate, or validate the technical details of your bucket elevators. Maxi-Lift is here to help you solve your elevator problems. We specialize in troubleshooting existing elevators, assessing upgrade capacity for new demands, and verifying your existing elevator setup. No problem is too big or too small for our team. Contact us today to find out more about our technical services.

OUR BUSINESS IS BUILT ON OUR CUSTOMERS

Our customers are the life blood of our business, and our long-term relationships are integral to our success. Not only do we develop, train and inspire our own team to grow, we want our relationships to grow as well. By working together and listening, we can solve your needs, provide better reliability, and lower the cost of operation.

Don't simply take our word for it, see the difference yourself! Contact Maxi-Lift today to receive free samples, engineering support, or to place an order. Join our thousands of Maxi-Lift customers, you too will love the results!

MAXI-LIFT: SUPERIOR PRODUCTS. MAXIMUM PERFORMANCE.

AGRICULTURAL PRODUCT LINES

Products, Materials & Applications

MAXIMUM DUTY



TIGER-TUFF Pg 16, **TIGER-CC** Pg 22
Polyethylene - Food Grade Applications



TIGER-TUFF Pg 18, **TIGER-CC** Pg 24
Nylon - Hot, Abrasive Applications



TIGER-TUFF Pg 19, **TIGER-CC** Pg 25
Urethane - Sticky, abrasive applications

HEAVY DUTY



HD-MAX Polyethylene
Food Grade Applications - Pg 28



HD-MAX Nylon
Hot, Abrasive Applications - Pg 30



HD-MAX Urethane
Sticky, Abrasive Applications - Pg 31

HEAVY DUTY



CC-MAX Polyethylene
Food Grade Applications - Pg 34



CC-MAX Nylon
Hot, Abrasive Applications - Pg 36



CC-MAX Urethane
Sticky, Abrasive Applications - Pg 37

STANDARD DUTY



DURA-BUKET Polyethylene
Food Grade Applications - Pg 40



STANDARD DUTY STEEL CC
Fabricated Steel - Pgs 43-44



STANDARD DUTY CC DIGGER
Clears Packed Materials - Pg 45

ACCESSORIES



Elevator Bolts & Accessories
Pgs 84-85



TITAN Pgs 86-87 & **MAXI-SPLICE** Pgs 88-89
Belt Fastening Systems



Screw Conveyor Hanger Bearings - Pg 90



Drag Flights, Custom UHMW Parts - Pgs 92-93

INDUSTRIAL PRODUCT LINES

Products, Materials & Applications

MAXIMUM DUTY



MAXI-TUFF AA Nylon
Hot, Abrasive Applications - Pg 52



MAXI-TUFF AA Urethane
Sharp Cutting Applications - Pg 53



MAXI-TUFF AA Polyethylene
Food Grade Applications - Pg 54

MAXIMUM DUTY



TIGER-TUFF Pgs 58-63, **TIGER-CC** Pgs 64-69
Industrial Buckets



DI-MAX AA
Ductile Iron Elevator Buckets - Pgs 70-72



DI-MAX AC
Ductile Iron Elevator Buckets - Pg 73

MAXIMUM DUTY



MAXI-TUFF MF (Medium Front)
Nylon: Hot, Abrasive Applications - Pgs 56-57



MAXI-TUFF MF (Medium Front)
Urethane: Sharp Cutting Applications - Pgs 56-57



MAXI-TUFF MF (Medium Front)
Polyethylene: Food Grade Applications - Pgs 56-57

FABRICATED STEEL



AA FABRICATED STEEL
Centrifugal Discharge - Pg 75



MF, HF & LF FABRICATED STEEL
Continuous Style - Pgs 78-80



SC FABRICATED STEEL
Super Capacity - Pg 77

FABRICATED STEEL



AC FABRICATED STEEL
Powdery Applications - Pg 76



ACS FABRICATED STEEL
Saddle Bag Style - Pg 81



CUSTOMIZED FABRICATED STEEL
Made To Order - Pg 82

HOW TO ORDER BUCKETS

Measuring, Style, Venting & Material Options

STEP 1. Measure Your Elevator Bucket

Most manufacturers identify part sizes by molding dimensions into the bottom of the elevator bucket.

LENGTH = 12 7/8"

The bucket length is measured at the back mounting surface. Lay the bucket on its back for actual measurement dimensions.



PROJECTION = 8 7/8"

Projection is measured vertically to the lip, as it would project from the belt or chain.



DEPTH = 8 1/4"

Depth is measured for the overall side profile dimension.



STEP 2. Select Your Bucket Style

There are two main categories of elevator buckets; agricultural and industrial. Our agricultural buckets are located on pages 12-45 and the industrial buckets are on pages 48-82. More styles are available online at maxlift.com.

TIGER-TUFF MAXIMUM DUTY: AGRICULTURAL



TIGER-CC MAXIMUM DUTY: AGRICULTURAL



HD-MAX HEAVY DUTY: AGRICULTURAL



CC-MAX CC-STYLE: AGRICULTURAL



MAXI-TUFF HEAVY DUTY: INDUSTRIAL



STEP 3. Choose Your Bucket Material

Buckets are available in the following materials, plus ductile iron and steel for industrial applications.

| | POLYETHYLENE | NYLON | URETHANE | FDA NYLON |
|------------------------------|--|--|---|---|
| Color | | | | |
| Application | Grain & Food Products | Hot, high impact, abrasive dense products | Heavy abrasion, sticky materials | Hot, high impact, abrasive food grade products |
| Temperature Range | -120° F to + 180° F (210° F Intermittent) | -60° F to + 300° F (350° F Intermittent) | -60° F to + 180° F (210° F Intermittent) | -60° F to + 300° F |
| FDA Approved Material | Yes | No | Yes | Yes |
| Comments | Economical, high density polyethylene. FDA approved material for handling food grade products. | Best for high heat applications, with tough impact and abrasion needs. | Most flexible and abrasion resistant. Resists product sticking and sharp cutting particles. | Best for high heat food grade applications, with tough impact and abrasion needs. |

STEP 4. Pick Your Bucket Vent Pattern (Call for Industrial Bucket venting recommendations)

Venting an elevator bucket aids in bucket fill and discharge with light, fluffy materials. Lightweight, fluffy materials, and those that are extremely dense or flow poorly can be difficult to handle in bucket elevators at high speeds. Because these materials tend to trap air when being handled by an elevator bucket, it is necessary to provide air relief to assist in their filling and discharge. Materials in this category might be various flours, meals, feed mash or screenings. As these materials enter the bucket, air is released through a series of vent holes in the bottom of the bucket allowing for a more complete fill. These vent holes also allow air to re-enter the bucket, which facilitates full release of product into the discharge. **Standard hole diameter is equal to the size of the bolt mounting holes. Anything different is considered a custom vent.**

#1 VENT - Same holes in body as bolt mounting holes.

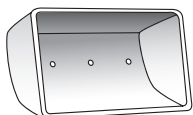

#2 VENT - One row of holes on 1-1/8" centers

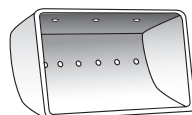

#3 VENT - Two rows of holes on 1-1/8" centers

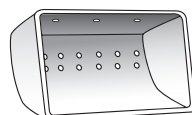

#4 VENT - Same as #3, plus three holes in each end cap.

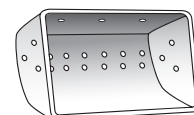

CUSTOM VENT - Ventated as required

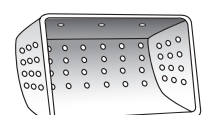

STEP 5. Contact Maxi-Lift For Quote

MAXI-LIFT

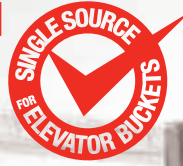

AGRICULTURAL ELEVATOR BUCKETS

UPGRADE TO THE TOUGHEST
ELEVATOR BUCKETS

- **TIGER-TUFF**
MAXIMUM DUTY
- **TIGER-CC**
MAXIMUM DUTY
- **HD-MAX**
HEAVY DUTY
- **CC-MAX**
HEAVY DUTY
- **DURA-BUKET**
STANDARD DUTY

MAXI-LIFT



NEW PRODUCTS

Never Content To Rest On Yesterday's Success



13 NEW SIZES!

THE MAXI-LIFT TITAN

UPGRADE TO THE ULTIMATE BELT SPLICE

Introducing the Maxi-Lift **TITAN**, the Ultimate Elevator Belt Splice. **TITAN's** innovative design, maximum duty solid aluminum construction and superior quality materials make other splices obsolete for heavy elevator belts. The **TITAN** sets a new standard for splice performance. The **TITAN** is constructed of a central aluminum vice-grip section which is bracketed by two exterior solid aluminum clamps.

See Pages 86-87 for Details.

TIGER-TUFF IS GROWING!

MORE SIZES MAKE THE TIGER LINE EVEN BETTER

How do you improve on the toughest elevator buckets on the market? Make more of them of course. Maxi-Lift is proud to announce that we have expanded our line of **TIGER-TUFF** Maximum Duty Elevator Buckets. We have added thirteen new sizes in all, bringing the total number to 30 SIZES, in standard and low profiles, available in five different materials... *that's 300 different TIGERS to choose from!*

See Page 12-19 for Details.

NEW PRODUCTS

Continually Striving To Bring You Better Products

MAXI-SPLICE BELT FASTENER

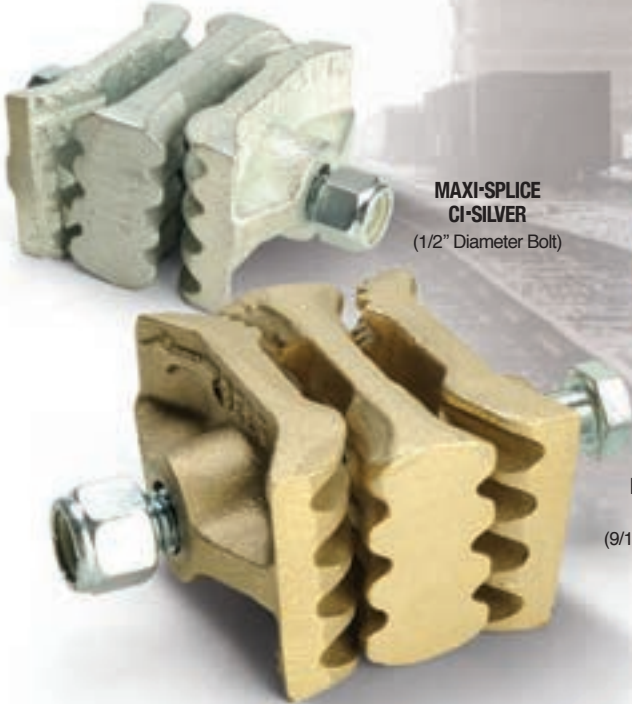

MAXI-SPLICE
CI-SILVER
(1/2" Diameter Bolt)

MAXI-SPLICE
AB BRONZE
(9/16" Diameter Bolt)



**14 NEW
SIZES!**

MAXI-SPLICE MAXIMIZED

TIGER-CC ROOAAARS!

THE AB MAXI-SPLICE GETS AN UPGRADE

BIGGER, BADDER, AND BETTER THAN EVER.

Our AB Maxi-Splice, our best selling model, is now even better. This non-sparking version of the Maxi-Splice is now supplied with a 9/16" diameter bolt, replacing the 1/2" diameter bolt. This increase in bolt size provides nearly 30% more bolt tensile strength. This upgrade gives the user the added security when splicing together that important elevator belt.

Our new **TIGER-CC** is taking elevator bucket and elevator design to new heights. These monster buckets redefine standards for high capacity bucket elevators with never before seen sizes and configurations. Maxi-Lift continues to push the envelope to address the demands of our customers. The next generation has arrived, and it's all **TIGER**.

See Page 88-89 for Details.

See Page 20-25 for Details.

TIGER-TUFF® MAXIMUM DUTY

High Speed Centrifugal Discharge 210 - 900 FPM

THE MAXI-LIFT TIGER-TUFF



TIGER-TUFF
MAXIMUM DUTY ELEVATOR BUCKETS®

UPGRADE TO THE TOUGHEST ELEVATOR BUCKET

THICKER. TOUGHER. LASTS LONGER:
WHEN YOU DON'T HAVE TIME FOR DOWN-TIME

DESIGNED FOR THE TOUGHEST APPLICATIONS:
PORT FACILITIES, RIVER TERMINALS, ETHANOL
AND PROCESSING PLANTS

ENGINEERED FOR ULTIMATE RELIABILITY:
THE THICKEST FRONT LIP AND CORNERS GIVE
LONGEST BUCKET LIFE



© The color orange, as applied to buckets, is a registered trademark of Maxi-Lift, Inc.

FEATURES & BENEFITS

- Thicker Corners
- Thicker Walls, Heavy Front Lip for Digging
- Cleaner Discharge
- High Impact & Abrasion Resistant
- Non-Corrosive, Non-Sparking
- Extends Bucket Life
- Increases Elevator Capacity
- Lowers Elevator Maintenance
- Decreases Elevator Down Time



Heavy Front Lip



Reinforced Corners



Thick Back Wall



Maximum Duty Design

TIGER-TUFF® MAXIMUM DUTY

On Location / Installation



TIGER-TUFF® MAXIMUM DUTY





High Speed Centrifugal Discharge 210 - 900 FPM



TIGER-TUFF

MAXIMUM DUTY ELEVATOR BUCKETS®

AVAILABLE MATERIALS

| | POLYETHYLENE | NYLON | URETHANE | FDA NYLON |
|------------------------------|--|--|--|--|
| Color |  Orange |  Tan |  Green |  White |
| Application | Grain & Food Products | Hot, high impact, abrasive dense products | Heavy abrasion, sticky materials | Hot, high impact, abrasive food grade products |
| Temperature Range | -120° F to + 180° F (210° F Intermittent) | -60° F to + 300° F (350° F Intermittent) | -60° F to + 180° F (210° F Intermittent) | -60° F to + 300° F |
| FDA Approved Material | Yes | No | Yes | Yes |
| Comments | Economical, high density polyethylene. FDA approved material for handling food grade products. | Best for high heat applications, with tough impact and abrasion needs. | Most flexible and abrasion resistant. Resists product sticking and sharp cutting particles. | Best for high heat food grade applications, with tough impact and abrasion needs. |

APPLICATIONS



FOOD
Barley, Beans, Corn, Cotton Seed, Coffee, Flour, Grains, Nuts, Rice, Sunflower, Oats, Salt, Sugar, Wheat, etc.



FEED
Bone Meal, Pellets, Meat Scrap, etc.



OTHER
Seeds, Grass Seed, Fertilizer, Perlite, Potash, Sawdust, Minerals, etc.

TIGER-TUFF®: PROFILES

Which Bucket is Right For You?



TIGER-TUFF® STANDARD PROFILE

The **TIGER-TUFF** is the original maximum duty elevator bucket, designed and engineered to increase bucket life and reduce breakage. This will reduce down time and lower maintenance costs. The **TIGER-TUFF** bucket has the thickest lip, back wall and corners to extend the life of the bucket. The most common applications include grain, fertilizers, pellets, corn, wheat, soybeans and other agricultural and light industrial applications. This is the best bucket for high volume applications. The recommended belt width for a single row of buckets is actual bucket width plus 2".

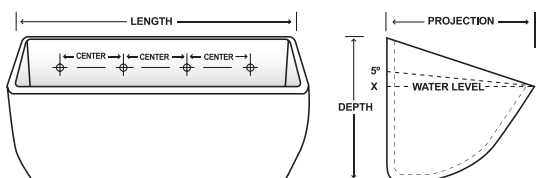

TIGER-TUFF® LOW PROFILE

The **TIGER-TUFF Low Profile** has all of the benefits of the original **TIGER-TUFF** bucket, with a reduced height modification for closer vertical spacing on the belt. The low profile system allows more buckets per foot of elevator belt. When upgrading to **TIGER-TUFF Low Profile** buckets, horsepower requirements must be evaluated due to increased capacity.

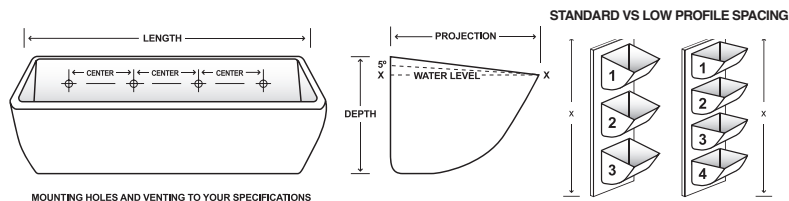

OTHER CONSIDERATIONS

ENGINEERING: Please see Section 5 of catalog for detailed engineering, speed and capacity information.

DRILLING: Elevator Buckets are manufactured without a drill pattern. Special drilling or punching can be accommodated upon customer request.

*Mounting Holes drilled 1/32 to 1/16 over bolt diameter for easier installation.

VENTING: Available as needed. See venting options in this catalog.

DIGGER BUCKETS: Use slightly larger metal digger elevator buckets to help loosen material in the elevator boot section that has set up or hardened, thereby reducing abrasion on the plastic buckets. Call for details on Metal Digger elevator bucket options.

SPACING: See elevator bucket spacing details in the Tiger-Tuff® chart (depending on materials and speeds, smaller and larger spacing may be used).

INSTALLATION: Use a #1 standard elevator bolt or Sabre-Tooth elevator bolt for installation. Designed to be used with fender or flat and lock washers and hex or locking nuts. If buckets are being installed on chain, use hex head bolts, nuts and washers. A locking device should always be used.

ADAPTER PLATES: Recommended for chain mounting applications.

FDA: Both the urethane and polyethylene are designed to FDA specifications for direct contact with food products.

USABLE CAPACITY: Under normal usage, the Tiger-Tuff® elevator bucket will carry and deliver +5° of the water level cubic inch capacity.

Maxi-Lift recommends that water level capacity be used for design and engineering purposes.

© The color orange, as applied to buckets, is a registered trademark of Maxi-Lift, Inc.

TIGER-TUFF® MAXIMUM DUTY

Standard Profile: Polyethylene

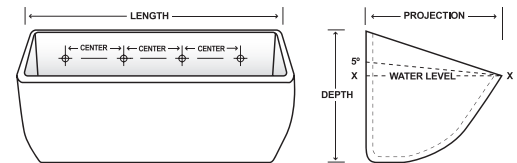

MOUNTING HOLES AND VENTING TO YOUR SPECIFICATIONS

® The color orange, as applied to buckets, is a registered trademark of Maxi-Lift, Inc.

Available Materials:

TIGER-TUFF® Maximum Duty: Polyethylene

| BUCKET SIZE, INCHES* | | | | | PUNCHING, IN.** | | | | WEIGHT, LBS | CAPACITY, CU. IN. | | |
|----------------------|--------|--------|-------|---------------------|-----------------|------------|-----------|----------|-------------|-------------------|---------------|-------------|
| BUCKET SIZE | Length | Proj. | Depth | Back Wall Thickness | Centers | # of Holes | Bolt Size | Top Down | HDPE | Water Level | Usable 5 Deg. | Std Spacing |
| 6 x 5 | 6-5/8 | 5-3/4 | 5 | 0.33 | 4-3/8 | 2 | 1/4 | 1-5/8 | 0.94 | 67.20 | 73.98 | 7 |
| 7 x 5 | 7-5/8 | 5-3/4 | 5 | 0.33 | 2-11/16 | 3 | 1/4 | 1-5/8 | 1.10 | 79.72 | 89.24 | 7 |
| 8 x 5 | 8-5/8 | 5-3/4 | 5 | 0.33 | 3-1/16 | 3 | 1/4 | 1-5/8 | 1.25 | 88.54 | 97.98 | 7 |
| 9 x 5 | 9-5/8 | 5-3/4 | 5 | 0.33 | 3-5/8 | 3 | 1/4 | 1-5/8 | 1.41 | 107.37 | 121.27 | 7 |
| 10 x 5 | 10-5/8 | 5-3/4 | 5 | 0.33 | 4-1/8 | 3 | 1/4 | 1-5/8 | 1.57 | 121.30 | 138.89 | 7 |
| 11 x 5 | 11-5/8 | 5-3/4 | 5 | 0.33 | 3 | 4 | 1/4 | 1-5/8 | 1.72 | 140.70 | 153.16 | 7 |
| 12 x 5 | 12-5/8 | 5-3/4 | 5 | 0.33 | 3-3/8 | 4 | 1/4 | 1-5/8 | 1.88 | 159.87 | 167.14 | 7 |
| 8 x 6 | 8-5/8 | 6-7/8 | 6 | 0.40 | 3-1/16 | 3 | 1/4 | 1-5/8 | 1.82 | 135.56 | 150.85 | 8 |
| 9 x 6 | 9-5/8 | 6-7/8 | 6 | 0.40 | 3-5/8 | 3 | 1/4 | 1-5/8 | 1.97 | 150.26 | 165.87 | 8 |
| 10 x 6 | 10-5/8 | 6-7/8 | 6 | 0.40 | 4-1/8 | 3 | 1/4 | 1-5/8 | 2.13 | 170.69 | 185.62 | 8 |
| 11 x 6 | 11-5/8 | 6-7/8 | 6 | 0.40 | 3 | 4 | 1/4 | 1-5/8 | 2.29 | 185.18 | 200.36 | 8 |
| 12 x 6 | 12-5/8 | 6-7/8 | 6 | 0.40 | 3-3/8 | 4 | 1/4 | 1-5/8 | 2.44 | 200.37 | 220.58 | 8 |
| 13 x 6 | 13-5/8 | 6-7/8 | 6 | 0.40 | 3-5/8 | 4 | 1/4 | 1-5/8 | 2.60 | 220.78 | 240.48 | 8 |
| 12 x 7 | 12-7/8 | 7-7/8 | 7 | 0.42 | 3-3/8 | 4 | 5/16 | 2 | 3.60 | 269.24 | 298.12 | 9 |
| 13 x 7 | 13-7/8 | 7-7/8 | 7 | 0.42 | 3-5/8 | 4 | 5/16 | 2 | 3.86 | 292.51 | 323.22 | 9 |
| 14 x 7 | 14-7/8 | 7-7/8 | 7 | 0.42 | 3 | 5 | 5/16 | 2 | 4.14 | 315.77 | 350.58 | 9 |
| 15 x 7 | 15-7/8 | 7-7/8 | 7 | 0.42 | 3-1/4 | 5 | 5/16 | 2 | 4.47 | 346.64 | 383.38 | 9 |
| 16 x 7 | 16-7/8 | 7-7/8 | 7 | 0.42 | 2-7/8 | 6 | 5/16 | 2 | 4.68 | 377.41 | 415.14 | 9 |
| 11 x 8 | 11-7/8 | 8-7/8 | 8-1/4 | 0.50 | 3 | 4 | 5/16 | 2 | 4.45 | 340.02 | 374.70 | 10 |
| 12 x 8 | 12-7/8 | 8-7/8 | 8-1/4 | 0.50 | 3-3/8 | 4 | 5/16 | 2 | 4.71 | 373.00 | 411.05 | 10 |
| 13 x 8 | 13-7/8 | 8-7/8 | 8-1/4 | 0.50 | 3-5/8 | 4 | 5/16 | 2 | 4.92 | 404.85 | 446.15 | 10 |
| 14 x 8 | 14-7/8 | 8-7/8 | 8-1/4 | 0.50 | 3 | 5 | 5/16 | 2 | 5.30 | 436.80 | 481.35 | 10 |
| 16 x 8 | 17 | 9-1/4 | 8-1/4 | 0.50 | 2-7/8 | 6 | 5/16 | 2-1/2 | 5.35 | 512.57 | 566.39 | 10 |
| 18 x 8 | 19 | 9-1/4 | 8-1/4 | 0.50 | 3-1/8 | 6 | 5/16 | 2-1/2 | 5.89 | 567.49 | 627.08 | 10 |
| 20 x 8 | 21 | 9-1/4 | 8-1/4 | 0.50 | 3-1/2 | 6 | 5/16 | 2-1/2 | 6.62 | 646.81 | 714.73 | 10 |
| 22 x 8 | 23 | 9-1/4 | 8-1/4 | 0.50 | 4 | 6 | 5/16 | 2-1/2 | 7.85 | 701.90 | 757.40 | 10 |
| 24 x 8 | 25 | 9-1/4 | 8-1/4 | 0.50 | 3-1/2 | 7 | 5/16 | 2-1/2 | 8.50 | 763.40 | 831.08 | 10 |
| 16 x 10 | 17 | 11-1/4 | 10 | 0.75 | 2-7/8 | 6 | 5/16 | 2-1/2 | 8.87 | 795.70 | 875.37 | 12 |
| 18 x 10 | 19 | 11-1/4 | 10 | 0.75 | 3-1/8 | 6 | 5/16 | 2-1/2 | 9.83 | 910.00 | 1001.21 | 12 |
| 20 x 10 | 21 | 11-1/4 | 10 | 0.75 | 3-1/2 | 6 | 5/16 | 2-1/2 | 10.57 | 1032.50 | 1135.98 | 12 |

■ Indicates TIGER-TUFF punch pattern differs from HD-MAX. TIGER-TUFF and CC-MAX standard patterns are the same. Reference Punching Chart on page 100.

■ New Sizes ■ Enhanced Designs. *Some sizes are made to order. Disclaimer: New weights, dimensions, & capacities are estimated. Actual measurements may vary. Injection molded materials shrink at differing rates. External dimensions may vary. For tight tolerances, contact Maxi-Lift for additional information.

High Speed Centrifugal Discharge 210 - 900 FPM

TIGER-TUFF® MAXIMUM DUTY

Low Profile: Polyethylene, Nylon, Urethane



**NEW SIZES!
ENHANCED
DESIGNS**

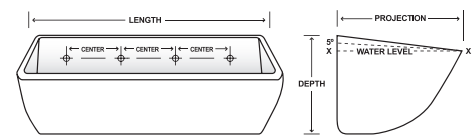
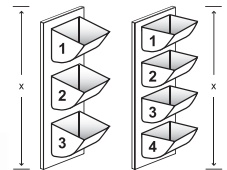

© The color orange, as applied to buckets, is a registered trademark of Maxi-Lift, Inc.

STANDARD VS LOW PROFILE SPACING

MOUNTING HOLES AND VENTING TO YOUR SPECIFICATIONS

Available Materials: Orange Grey Green Blue

TIGER-TUFF® LOW PROFILE Maximum Duty

| BUCKET SIZE, INCHES* | | | | | PUNCHING, IN.** | | | | WEIGHT, LBS. | | | CAPACITY, CU. IN. | | |
|----------------------|--------|--------|-------|---------------------|-----------------|------------|-----------|----------|--------------|-------|-------|-------------------|---------------|-------------|
| BUCKET SIZE | Length | Proj. | Depth | Back Wall Thickness | Centers | # of Holes | Bolt Size | Top Down | HDPE | Nylon | Uret | Water Level | Usable 5 Deg. | Std Spacing |
| 6 x 5 | 6-5/8 | 5-3/4 | 4 | 0.33 | 4-3/8 | 2 | 1/4 | 1 | 0.84 | - | - | 67.20 | 73.98 | 4 |
| 7 x 5 | 7-5/8 | 5-3/4 | 4 | 0.33 | 2-11/16 | 3 | 1/4 | 1 | 0.98 | - | - | 79.72 | 89.24 | 4 |
| 8 x 5 | 8-5/8 | 5-3/4 | 4 | 0.33 | 3-1/16 | 3 | 1/4 | 1 | 1.11 | - | - | 88.54 | 97.98 | 4 |
| 9 x 5 | 9-5/8 | 5-3/4 | 4 | 0.33 | 3-5/8 | 3 | 1/4 | 1 | 1.25 | - | - | 107.37 | 121.27 | 4 |
| 10 x 5 | 10-5/8 | 5-3/4 | 4 | 0.33 | 4-1/8 | 3 | 1/4 | 1 | 1.40 | - | - | 121.30 | 138.89 | 4 |
| 11 x 5 | 11-5/8 | 5-3/4 | 4 | 0.33 | 3 | 4 | 1/4 | 1 | 1.53 | - | - | 140.70 | 153.16 | 4 |
| 12 x 5 | 12-5/8 | 5-3/4 | 4 | 0.33 | 3-3/8 | 4 | 1/4 | 1 | 1.67 | - | - | 159.87 | 167.14 | 4 |
| 8 x 6 | 8-5/8 | 6-7/8 | 5 | 0.40 | 3-1/16 | 3 | 1/4 | 1 | 1.64 | - | - | 135.56 | 150.85 | 5 |
| 9 x 6 | 9-5/8 | 6-7/8 | 5 | 0.40 | 3-5/8 | 3 | 1/4 | 1 | 1.77 | - | - | 150.26 | 165.87 | 5 |
| 10 x 6 | 10-5/8 | 6-7/8 | 5 | 0.40 | 4-1/8 | 3 | 1/4 | 1 | 1.92 | - | - | 170.69 | 185.62 | 5 |
| 11 x 6 | 11-5/8 | 6-7/8 | 5 | 0.40 | 3 | 4 | 1/4 | 1 | 2.06 | - | - | 185.18 | 200.36 | 5 |
| 12 x 6 | 12-5/8 | 6-7/8 | 5 | 0.40 | 3-3/8 | 4 | 1/4 | 1 | 2.20 | - | - | 200.37 | 220.58 | 5 |
| 13 x 6 | 13-5/8 | 6-7/8 | 5 | 0.40 | 3-5/8 | 4 | 1/4 | 1 | 2.34 | - | - | 220.78 | 240.48 | 5 |
| 12 x 7 | 12-7/8 | 7-7/8 | 5-3/4 | 0.42 | 3-3/8 | 4 | 5/16 | 1 | 3.24 | 3.55 | 3.98 | 269.24 | 298.12 | 6 |
| 13 x 7 | 13-7/8 | 7-7/8 | 5-3/4 | 0.42 | 3-5/8 | 4 | 5/16 | 1 | 3.47 | 3.82 | 4.29 | 292.51 | 323.22 | 6 |
| 14 x 7 | 14-7/8 | 7-7/8 | 5-3/4 | 0.42 | 3 | 5 | 5/16 | 1 | 3.73 | 4.07 | 4.56 | 315.77 | 350.58 | 6 |
| 15 x 7 | 15-7/8 | 7-7/8 | 5-3/4 | 0.42 | 3-1/4 | 5 | 5/16 | 1 | 4.02 | 4.19 | 4.72 | 346.64 | 383.38 | 6 |
| 16 x 7 | 16-7/8 | 7-7/8 | 5-3/4 | 0.42 | 2-7/8 | 6 | 5/16 | 1 | 4.21 | 4.32 | 4.84 | 377.41 | 415.14 | 6 |
| 11 x 8 | 11-7/8 | 8-7/8 | 6-3/4 | 0.50 | 3 | 4 | 5/16 | 1 | 4.01 | 4.33 | 5.08 | 340.02 | 374.70 | 7 |
| 12 x 8 | 12-7/8 | 8-7/8 | 6-3/4 | 0.50 | 3-3/8 | 4 | 5/16 | 1 | 4.24 | 4.58 | 5.45 | 373.00 | 411.05 | 7 |
| 13 x 8 | 13-7/8 | 8-7/8 | 6-3/4 | 0.50 | 3-5/8 | 4 | 5/16 | 1 | 4.43 | 4.66 | 5.60 | 404.85 | 446.15 | 7 |
| 14 x 8 | 14-7/8 | 8-7/8 | 6-3/4 | 0.50 | 3 | 5 | 5/16 | 1 | 4.77 | 5.02 | 5.99 | 436.80 | 481.35 | 7 |
| 16 x 8 | 17 | 9-1/4 | 6-3/4 | 0.50 | 2-7/8 | 6 | 5/16 | 1 | 4.82 | 5.68 | 6.96 | 512.57 | 566.39 | 7 |
| 18 x 8 | 19 | 9-1/4 | 6-3/4 | 0.50 | 3-1/8 | 6 | 5/16 | 1 | 5.89 | 6.39 | 7.45 | 567.49 | 627.08 | 7 |
| 20 x 8 | 21 | 9-1/4 | 6-3/4 | 0.50 | 3-1/2 | 6 | 5/16 | 1 | 6.62 | 6.94 | 8.13 | 646.81 | 714.73 | 7 |
| 22 x 8 | 23 | 9-1/4 | 6-3/4 | 0.50 | 4 | 6 | 5/16 | 1 | 7.85 | 8.45 | 9.84 | 701.90 | 757.40 | 7 |
| 24 x 8 | 25 | 9-1/4 | 6-3/4 | 0.50 | 3-1/2 | 7 | 5/16 | 1 | 8.50 | 9.27 | 10.78 | 763.40 | 831.08 | 7 |
| 16 x 10 | 17 | 11-1/4 | 8-1/2 | 0.75 | 2-7/8 | 6 | 5/16 | 1 | 8.87 | 9.12 | 11.15 | 795.70 | 875.37 | 9 |
| 18 x 10 | 19 | 11-1/4 | 8-1/2 | 0.75 | 3-1/8 | 6 | 5/16 | 1 | 9.83 | 10.17 | 12.41 | 910.00 | 1001.21 | 9 |
| 20 x 10 | 21 | 11-1/4 | 8-1/2 | 0.75 | 3-1/2 | 6 | 5/16 | 1 | 10.27 | 11.02 | 13.09 | 1032.50 | 1135.98 | 9 |

■ Indicates TIGER-TUFF punch pattern differs from HD-MAX. TIGER-TUFF and CC-MAX standard patterns are the same. **Reference Punching Chart on page 100.
 ■ New Sizes ■ Enhanced Designs. *Some sizes are made to order. Disclaimer: New weights, dimensions, & capacities are estimated. Actual measurements may vary.
 Injection molded materials shrink at differing rates. External dimensions may vary. For tight tolerances, contact Maxi-Lift for additional information.

High Speed Centrifugal Discharge 210 - 900 FPM

TIGER-TUFF® MAXIMUM DUTY

Standard Profile: Nylon



**NEW SIZES!
ENHANCED
DESIGNS**

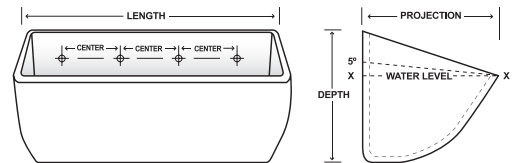

MOUNTING HOLES AND VENTING TO YOUR SPECIFICATIONS

Available Materials: Available Materials: ■ ■ ■ ■

TIGER-TUFF® Maximum Duty: Nylon

| BUCKET SIZE, INCHES* | | | | | PUNCHING, IN.** | | | | WEIGHT, LBS. | CAPACITY, CU. IN. | | |
|----------------------|----------|--------|-------|---------------------|-----------------|------------|-----------|----------|--------------|-------------------|---------------|-------------|
| BUCKET SIZE | Length** | Proj. | Depth | Back Wall Thickness | Centers | # of Holes | Bolt Size | Top Down | Nylon | Water Level | Usable 5 Deg. | Std Spacing |
| 6 x 5 | 6-5/8 | 5-3/4 | 5 | 0.33 | 4-3/8 | 2 | 1/4 | 1-5/8 | 1.08 | 67.20 | 73.98 | 7 |
| 7 x 5 | 7-5/8 | 5-3/4 | 5 | 0.33 | 2-11/16 | 3 | 1/4 | 1-5/8 | 1.26 | 79.72 | 89.24 | 7 |
| 8 x 5 | 8-5/8 | 5-3/4 | 5 | 0.33 | 3-1/16 | 3 | 1/4 | 1-5/8 | 1.44 | 88.54 | 97.98 | 7 |
| 9 x 5 | 9-5/8 | 5-3/4 | 5 | 0.33 | 3-5/8 | 3 | 1/4 | 1-5/8 | 1.60 | 107.37 | 121.27 | 7 |
| 10 x 5 | 10-5/8 | 5-3/4 | 5 | 0.33 | 4-1/8 | 3 | 1/4 | 1-5/8 | 1.80 | 121.30 | 138.89 | 7 |
| 11 x 5 | 11-5/8 | 5-3/4 | 5 | 0.33 | 3 | 4 | 1/4 | 1-5/8 | 1.98 | 140.70 | 153.16 | 7 |
| 12 x 5 | 12-5/8 | 5-3/4 | 5 | 0.33 | 3-3/8 | 4 | 1/4 | 1-5/8 | 2.16 | 159.87 | 167.14 | 7 |
| 8 x 6 | 8-5/8 | 6-7/8 | 6 | 0.40 | 3-1/16 | 3 | 1/4 | 1-5/8 | 2.09 | 135.56 | 150.85 | 8 |
| 9 x 6 | 9-5/8 | 6-7/8 | 6 | 0.40 | 3-5/8 | 3 | 1/4 | 1-5/8 | 2.26 | 150.26 | 165.87 | 8 |
| 10 x 6 | 10-5/8 | 6-7/8 | 6 | 0.40 | 4-1/8 | 3 | 1/4 | 1-5/8 | 2.40 | 170.69 | 185.62 | 8 |
| 11 x 6 | 11-5/8 | 6-7/8 | 6 | 0.40 | 3 | 4 | 1/4 | 1-5/8 | 2.63 | 185.18 | 200.36 | 8 |
| 12 x 6 | 12-5/8 | 6-7/8 | 6 | 0.40 | 3-3/8 | 4 | 1/4 | 1-5/8 | 2.81 | 200.37 | 220.58 | 8 |
| 13 x 6 | 13-5/8 | 6-7/8 | 6 | 0.40 | 3-5/8 | 4 | 1/4 | 1-5/8 | 2.99 | 220.78 | 240.48 | 8 |
| 12 x 7 | 12-7/8 | 7-7/8 | 7 | 0.42 | 3-3/8 | 4 | 5/16 | 2 | 4.00 | 269.24 | 298.12 | 9 |
| 13 x 7 | 13-7/8 | 7-7/8 | 7 | 0.42 | 3-5/8 | 4 | 5/16 | 2 | 4.44 | 292.51 | 323.22 | 9 |
| 14 x 7 | 14-7/8 | 7-7/8 | 7 | 0.42 | 3 | 5 | 5/16 | 2 | 4.75 | 315.77 | 350.58 | 9 |
| 15 x 7 | 15-7/8 | 7-7/8 | 7 | 0.42 | 3-1/4 | 5 | 5/16 | 2 | 5.00 | 346.64 | 383.38 | 9 |
| 16 x 7 | 16-7/8 | 7-7/8 | 7 | 0.42 | 2-7/8 | 6 | 5/16 | 2 | 5.50 | 377.41 | 415.14 | 9 |
| 11 x 8 | 11-7/8 | 8-7/8 | 8-1/4 | 0.50 | 3 | 4 | 5/16 | 2 | 5.16 | 340.02 | 374.70 | 10 |
| 12 x 8 | 12-7/8 | 8-7/8 | 8-1/4 | 0.50 | 3-3/8 | 4 | 5/16 | 2 | 5.10 | 373.00 | 411.05 | 10 |
| 13 x 8 | 13-7/8 | 8-7/8 | 8-1/4 | 0.50 | 3-5/8 | 4 | 5/16 | 2 | 5.20 | 404.85 | 446.15 | 10 |
| 14 x 8 | 14-7/8 | 8-7/8 | 8-1/4 | 0.50 | 3 | 5 | 5/16 | 2 | 5.40 | 436.80 | 481.35 | 10 |
| 16 x 8 | 17 | 9-1/4 | 8-1/4 | 0.50 | 2-7/8 | 6 | 5/16 | 2-1/2 | 6.25 | 512.57 | 566.39 | 10 |
| 18 x 8 | 19 | 9-1/4 | 8-1/4 | 0.50 | 3-1/8 | 6 | 5/16 | 2-1/2 | 6.95 | 567.49 | 627.08 | 10 |
| 20 x 8 | 21 | 9-1/4 | 8-1/4 | 0.50 | 3-1/2 | 6 | 5/16 | 2-1/2 | 7.40 | 646.81 | 714.73 | 10 |
| 22 x 8 | 23 | 9-1/4 | 8-1/4 | 0.50 | 4 | 6 | 5/16 | 2-1/2 | 9.00 | 701.90 | 757.40 | 10 |
| 24 x 8 | 25 | 9-1/4 | 8-1/4 | 0.50 | 3-1/2 | 7 | 5/16 | 2-1/2 | 10.15 | 763.40 | 831.08 | 10 |
| 16 x 10 | 17 | 11-1/4 | 10 | 0.75 | 2-7/8 | 6 | 5/16 | 2-1/2 | 10.75 | 795.70 | 875.37 | 12 |
| 18 x 10 | 19 | 11-1/4 | 10 | 0.75 | 3-1/8 | 6 | 5/16 | 2-1/2 | 11.20 | 910.00 | 1001.21 | 12 |
| 20 x 10 | 21 | 11-1/4 | 10 | 0.75 | 3-1/2 | 6 | 5/16 | 2-1/2 | 11.95 | 1032.50 | 1135.98 | 12 |

■ Indicates TIGER-TUFF punch pattern differs from HD-MAX. TIGER-TUFF and CC-MAX standard patterns are the same. **Reference Punching Chart on page 100.
 ■ New Sizes ■ Enhanced Designs. *Some sizes are made to order. Disclaimer: New weights, dimensions, & capacities are estimated. Actual measurements may vary.
 Injection molded materials shrink at differing rates. External dimensions may vary. For tight tolerances, contact Maxi-Lift for additional information.

High Speed Centrifugal Discharge 210 - 900 FPM

TIGER-TUFF® MAXIMUM DUTY

Standard Profile: Urethane



**NEW SIZES!
ENHANCED
DESIGNS**

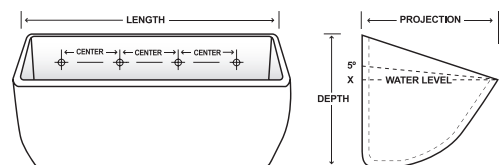

MOUNTING HOLES AND VENTING TO YOUR SPECIFICATIONS

Available Materials:

TIGER-TUFF® Maximum Duty: Urethane

| BUCKET SIZE, INCHES* | | | | | PUNCHING, IN.** | | | | WEIGHT, LBS. | CAPACITY, CU. IN. | | |
|----------------------|--------|--------|-------|---------------------|-----------------|------------|-----------|----------|--------------|-------------------|---------------|-------------|
| BUCKET SIZE | Length | Proj. | Depth | Back Wall Thickness | Centers | # of Holes | Bolt Size | Top Down | Uret | Water Level | Usable 5 Deg. | Std Spacing |
| 6 x 5 | 6-5/8 | 5-3/4 | 5 | 0.33 | 4-3/8 | 2 | 1/4 | 1-5/8 | 1.18 | 67.20 | 73.98 | 7 |
| 7 x 5 | 7-5/8 | 5-3/4 | 5 | 0.33 | 2-11/16 | 3 | 1/4 | 1-5/8 | 1.38 | 79.72 | 89.24 | 7 |
| 8 x 5 | 8-5/8 | 5-3/4 | 5 | 0.33 | 3-1/16 | 3 | 1/4 | 1-5/8 | 1.57 | 88.54 | 97.98 | 7 |
| 9 x 5 | 9-5/8 | 5-3/4 | 5 | 0.33 | 3-5/8 | 3 | 1/4 | 1-5/8 | 1.77 | 107.37 | 121.27 | 7 |
| 10 x 5 | 10-5/8 | 5-3/4 | 5 | 0.33 | 4-1/8 | 3 | 1/4 | 1-5/8 | 1.97 | 121.30 | 138.89 | 7 |
| 11 x 5 | 11-5/8 | 5-3/4 | 5 | 0.33 | 3 | 4 | 1/4 | 1-5/8 | 2.16 | 140.70 | 153.16 | 7 |
| 12 x 5 | 12-5/8 | 5-3/4 | 5 | 0.33 | 3-3/8 | 4 | 1/4 | 1-5/8 | 2.36 | 159.87 | 167.14 | 7 |
| 8 x 6 | 8-5/8 | 6-7/8 | 6 | 0.40 | 3-1/16 | 3 | 1/4 | 1-5/8 | 2.28 | 135.56 | 150.85 | 8 |
| 9 x 6 | 9-5/8 | 6-7/8 | 6 | 0.40 | 3-5/8 | 3 | 1/4 | 1-5/8 | 2.47 | 150.26 | 165.87 | 8 |
| 10 x 6 | 10-5/8 | 6-7/8 | 6 | 0.40 | 4-1/8 | 3 | 1/4 | 1-5/8 | 2.67 | 170.69 | 185.62 | 8 |
| 11 x 6 | 11-5/8 | 6-7/8 | 6 | 0.40 | 3 | 4 | 1/4 | 1-5/8 | 2.87 | 185.18 | 200.36 | 8 |
| 12 x 6 | 12-5/8 | 6-7/8 | 6 | 0.40 | 3-3/8 | 4 | 1/4 | 1-5/8 | 3.05 | 200.37 | 220.58 | 8 |
| 13 x 6 | 13-5/8 | 6-7/8 | 6 | 0.40 | 3-5/8 | 4 | 1/4 | 1-5/8 | 3.25 | 220.78 | 240.48 | 8 |
| 12 x 7 | 12-7/8 | 7-7/8 | 7 | 0.42 | 3-3/8 | 4 | 5/16 | 2 | 4.85 | 269.24 | 298.12 | 9 |
| 13 x 7 | 13-7/8 | 7-7/8 | 7 | 0.42 | 3-5/8 | 4 | 5/16 | 2 | 5.50 | 292.51 | 323.22 | 9 |
| 14 x 7 | 14-7/8 | 7-7/8 | 7 | 0.42 | 3 | 5 | 5/16 | 2 | 5.75 | 315.77 | 350.58 | 9 |
| 15 x 7 | 15-7/8 | 7-7/8 | 7 | 0.42 | 3-1/4 | 5 | 5/16 | 2 | 5.85 | 346.64 | 383.38 | 9 |
| 16 x 7 | 16-7/8 | 7-7/8 | 7 | 0.42 | 2-7/8 | 6 | 5/16 | 2 | 5.95 | 377.41 | 415.14 | 9 |
| 11 x 8 | 11-7/8 | 8-7/8 | 8-1/4 | 0.50 | 3 | 4 | 5/16 | 2 | 6.02 | 340.02 | 374.70 | 10 |
| 12 x 8 | 12-7/8 | 8-7/8 | 8-1/4 | 0.50 | 3-3/8 | 4 | 5/16 | 2 | 5.95 | 373.00 | 411.05 | 10 |
| 13 x 8 | 13-7/8 | 8-7/8 | 8-1/4 | 0.50 | 3-5/8 | 4 | 5/16 | 2 | 6.30 | 404.85 | 446.15 | 10 |
| 14 x 8 | 14-7/8 | 8-7/8 | 8-1/4 | 0.50 | 3 | 5 | 5/16 | 2 | 6.55 | 436.80 | 481.35 | 10 |
| 16 x 8 | 17 | 9-1/4 | 8-1/4 | 0.50 | 2-7/8 | 6 | 5/16 | 2-1/2 | 7.40 | 512.57 | 566.39 | 10 |
| 18 x 8 | 19 | 9-1/4 | 8-1/4 | 0.50 | 3-1/8 | 6 | 5/16 | 2-1/2 | 8.08 | 567.49 | 627.08 | 10 |
| 20 x 8 | 21 | 9-1/4 | 8-1/4 | 0.50 | 3-1/2 | 6 | 5/16 | 2-1/2 | 8.80 | 646.81 | 714.73 | 10 |
| 22 x 8 | 23 | 9-1/4 | 8-1/4 | 0.50 | 4 | 6 | 5/16 | 2-1/2 | 11.02 | 701.90 | 757.40 | 10 |
| 24 x 8 | 25 | 9-1/4 | 8-1/4 | 0.50 | 3-1/2 | 7 | 5/16 | 2-1/2 | 11.75 | 763.40 | 831.08 | 10 |
| 16 x 10 | 17 | 11-1/4 | 10 | 0.75 | 2-7/8 | 6 | 5/16 | 2-1/2 | 12.24 | 795.70 | 875.37 | 12 |
| 18 x 10 | 19 | 11-1/4 | 10 | 0.75 | 3-1/8 | 6 | 5/16 | 2-1/2 | 13.45 | 910.00 | 1001.21 | 12 |
| 20 x 10 | 21 | 11-1/4 | 10 | 0.75 | 3-1/2 | 6 | 5/16 | 2-1/2 | 14.20 | 1032.50 | 1135.98 | 12 |

■ Indicates TIGER-TUFF punch pattern differs from HD-MAX. TIGER-TUFF and CC-MAX standard patterns are the same. **Reference Punching Chart on page 100.
 ■ New Sizes ■ Enhanced Designs. *Some sizes are made to order. Disclaimer: New weights, dimensions, & capacities are estimated. Actual measurements may vary.
 Injection molded materials shrink at differing rates. External dimensions may vary. For tight tolerances, contact Maxi-Lift for additional information.

High Speed Centrifugal Discharge 210 - 900 FPM

TIGER-CC® MAXIMUM DUTY

High Speed Centrifugal Discharge 210 - 900 FPM

THE MAXI-LIFT TIGER-CC



TIGER-CC
MAXIMUM DUTY ELEVATOR BUCKETS®

UPGRADE TO THE TOUGHEST ELEVATOR BUCKET

THICKER. TOUGHER. LASTS LONGER:
FOR THOSE WHO DON'T HAVE TIME TO BE DOWN

DESIGNED FOR THE TOUGHEST APPLICATIONS:
PORT FACILITIES, RIVER TERMINALS, ETHANOL
AND PROCESSING PLANTS

ENGINEERED FOR ULTIMATE RELIABILITY:
REINFORCED WEAR POINTS MAKE THE TIGER-
CC STRONGER EVERYWHERE IT COUNTS



® The color orange, as applied to buckets, is a registered trademark of Maxi-Lift, Inc.

FEATURES & BENEFITS

- Traditional CC Style w/ High Sides and Breaks in the Bottom of Bucket
- Thicker Corners
- Thicker Walls, Heavy Front Lip for Digging
- Cleaner Discharge
- Heat, Impact & Abrasion Resistant
- Non-Corrosive, Non-Sparking
- Extends Bucket Life
- Increases Elevator Capacity
- Lowers Elevator Maintenance
- Decreases Elevator Down Time



Reinforced Corners



Heavy Front Lip



Traditional CC Breaks



Thick Back Wall





TIGER-CC® MAXIMUM DUTY

High Speed Centrifugal Discharge 210 - 900 FPM



TIGER-CC MAXIMUM DUTY ELEVATOR BUCKETS®

AVAILABLE MATERIALS

| | POLYETHYLENE | NYLON | URETHANE | FDA NYLON |
|------------------------------|--|--|--|--|
| Color |  Orange |  Tan |  Green |  White |
| Application | Grain & Food Products | Hot, high impact, abrasive dense products | Heavy abrasion, sticky materials | Hot, high impact, abrasive food grade products |
| Temperature Range | -120° F to + 180° F (210° F Intermittent) | -60° F to + 300° F (350° F Intermittent) | -60° F to + 180° F (210° F Intermittent) | -60° F to + 300° F |
| FDA Approved Material | Yes | No | Yes | Yes |
| Comments | Economical, high density polyethylene. FDA approved material for handling food grade products. | Best for high heat applications, with tough impact and abrasion needs. | Most flexible and abrasion resistant. Resists product sticking and sharp cutting particles. | Best for high heat food grade applications, with tough impact and abrasion needs. |

APPLICATIONS



FOOD
Barley, Beans, Corn, Cotton Seed, Coffee, Flour, Grains, Nuts, Rice, Sunflower, Oats, Salt, Sugar, Wheat, etc.



FEED
Bone Meal, Pellets, Meat Scrap, etc.



OTHER
Seeds, Grass Seed, Fertilizer, Perlite, Potash, Sawdust, Minerals, etc.

TIGER-CC® MAXIMUM DUTY

Standard Profile: Polyethylene

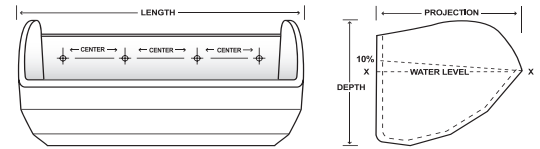

MOUNTING HOLES AND VENTING TO YOUR SPECIFICATIONS

® The color orange, as applied to buckets, is a registered trademark of Maxi-Lift, Inc.

Available Materials:

TIGER-CC® Maximum Duty: Polyethylene

The **TIGER-CC** Maximum Duty Elevator Buckets was designed to combine the style of the traditional CC elevator bucket with the ruggedness and toughness of the **TIGER-TUFF** elevator bucket. This will increase bucket life and provide less breakage and more capacity. The most common applications include grain, fertilizers, pellets, corn, wheat, soybeans and other agricultural and light industrial applications. The recommended belt width for a single row of buckets is actual bucket width plus 2".

| BUCKET SIZE, INCHES* | | | | | PUNCHING, IN.** | | | | WEIGHT, LBS. | CAPACITY, CU. IN. | | |
|----------------------|--------|--------|--------|---------------------|-----------------|------------|-----------|----------|--------------|-------------------|------------------|-------------|
| BUCKET SIZE | Length | Proj. | Depth | Back Wall Thickness | Centers | # of Holes | Bolt Size | Top Down | HDPE | Water Level | Water Level +10% | Std Spacing |
| 12 x 8 | 12-7/8 | 9-1/4 | 8-7/8 | 0.55 | 3-3/8 | 4 | 5/16 | 2 | 4.90 | 366 | 403 | 10 |
| 14 x 8 | 14-7/8 | 9-1/4 | 8-7/8 | 0.55 | 3 | 5 | 5/16 | 2 | 5.40 | 430 | 473 | 10 |
| 16 x 8 | 16-7/8 | 9-1/4 | 8-7/8 | 0.55 | 2-7/8 | 6 | 5/16 | 2 | 5.90 | 510 | 561 | 10 |
| 18 x 8 | 18-7/8 | 9-1/4 | 8-7/8 | 0.55 | 3-1/8 | 6 | 5/16 | 2 | 6.60 | 560 | 616 | 10 |
| 20 x 8 | 20-7/8 | 9-1/4 | 8-7/8 | 0.55 | 3-1/2 | 6 | 5/16 | 2 | 7.20 | 655 | 720 | 10 |
| 20 x 10 | 21 | 11-1/2 | 10-3/8 | 0.70 | 3-1/2 | 6 | 3/8 | 2-1/4 | 12.20 | 1005 | 1106 | 12 |
| 21 x 10 | 22 | 11-1/2 | 10-3/8 | 0.70 | 3-5/8 | 6 | 3/8 | 2-1/4 | 12.60 | 1055 | 1161 | 12 |
| 22 x 10 | 23 | 11-1/2 | 10-3/8 | 0.70 | 4 | 6 | 3/8 | 2-1/4 | 13.00 | 1105 | 1216 | 12 |
| 23 x 10 | 24 | 11-1/2 | 10-3/8 | 0.70 | 3-3/8 | 7 | 3/8 | 2-1/4 | 13.50 | 1155 | 1271 | 12 |
| 24 x 10 | 25 | 11-1/2 | 10-3/8 | 0.70 | 3-1/2 | 7 | 3/8 | 2-1/4 | 14.00 | 1206 | 1327 | 12 |
| 25 x 10 | 26 | 11-1/2 | 10-3/8 | 0.70 | 3-5/8 | 7 | 3/8 | 2-1/4 | 14.40 | 1256 | 1381 | 12 |
| 26 x 10 | 27 | 11-1/2 | 10-3/8 | 0.70 | 3-7/8 | 7 | 3/8 | 2-1/4 | 14.80 | 1306 | 1437 | 12 |
| 27 x 10 | 28 | 11-1/2 | 10-3/8 | 0.70 | 3-3/8 | 8 | 3/8 | 2-1/4 | 15.30 | 1356 | 1492 | 12 |
| 28 x 10 | 29 | 11-1/2 | 10-3/8 | 0.70 | 3-5/8 | 8 | 3/8 | 2-1/4 | 15.80 | 1400 | 1540 | 12 |

Available upon request - extended lead time required

* Injection molded materials shrink at differing rates. External dimensions may vary. For tight tolerances, contact Maxi-Lift for additional information.

Weights, Dimensions, and Capacities have been estimated from engineered elevator bucket drawings. Actual molded parts will vary from numbers on charts. Please contact Maxi-Lift for the most updated information.

**Reference Punching Chart on page 100.

High Speed Centrifugal Discharge 210 - 900 FPM

TIGER-CC® MAXIMUM DUTY

Low Profile: Polyethylene, Nylon, Urethane

**NEW SIZES!
ENHANCED
DESIGNS**

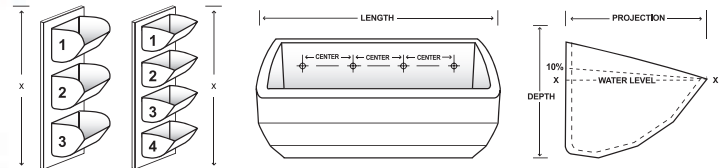

® The color orange, as applied to buckets, is a registered trademark of Maxi-Lift, Inc.

STANDARD VS LOW PROFILE SPACING

MOUNTING HOLES AND VENTING TO YOUR SPECIFICATIONS

Available Materials:



TIGER-CC® Maximum Duty Low Profile

The **TIGER-CC Low Profile** Maximum Duty Elevator Bucket has a reduced height modification for closer vertical spacing on the belt. The low profile system allows more buckets per foot of elevator belt. When upgrading to **TIGER-CC Low Profile** buckets, horsepower requirements must be evaluated due to increased capacity.

| BUCKET SIZE, INCHES* | | | | | PUNCHING, IN.** | | | | WEIGHT, LBS. | | | CAPACITY, CU. IN. | | |
|----------------------|--------|--------|-------|---------------------|-----------------|------------|-----------|----------|--------------|-------|------|-------------------|------------------|-------------|
| BUCKET SIZE | Length | Proj. | Depth | Back Wall Thickness | Centers | # of Holes | Bolt Size | Top Down | HDPE | Nylon | Uret | Water Level | Water Level + 5% | Std Spacing |
| 12 x 8 | 12-7/8 | 9-1/4 | 6-3/4 | 0.55 | 3-3/8 | 4 | 5/16 | 1 | 4.20 | - | - | 366 | 384 | 7 |
| 14 x 8 | 14-7/8 | 9-1/4 | 6-3/4 | 0.55 | 3 | 5 | 5/16 | 1 | 4.80 | - | - | 430 | 452 | 7 |
| 16 x 8 | 16-7/8 | 9-1/4 | 6-3/4 | 0.55 | 2-7/8 | 6 | 5/16 | 1 | 5.20 | - | - | 510 | 536 | 7 |
| 18 x 8 | 18-7/8 | 9-1/4 | 6-3/4 | 0.55 | 3-1/8 | 6 | 5/16 | 1 | 5.70 | - | - | 560 | 588 | 7 |
| 20 x 8 | 20-7/8 | 9-1/4 | 6-3/4 | 0.55 | 3-1/2 | 6 | 5/16 | 1 | 6.30 | 7.13 | 8.38 | 655 | 688 | 7 |
| 20 x 10 | 21 | 11-1/2 | 8-3/4 | 0.70 | 3-1/2 | 6 | 3/8 | 1-1/4 | 11.10 | - | - | 1005 | 1055 | 9 |
| 21 x 10 | 22 | 11-1/2 | 8-3/4 | 0.70 | 3-5/8 | 6 | 3/8 | 1-1/4 | 11.60 | - | - | 1055 | 1108 | 9 |
| 22 x 10 | 23 | 11-1/2 | 8-3/4 | 0.70 | 4 | 6 | 3/8 | 1-1/4 | 12.00 | - | - | 1105 | 1160 | 9 |
| 23 x 10 | 24 | 11-1/2 | 8-3/4 | 0.70 | 3-3/8 | 7 | 3/8 | 1-1/4 | 12.40 | - | - | 1155 | 1213 | 9 |
| 24 x 10 | 25 | 11-1/2 | 8-3/4 | 0.70 | 3-1/2 | 7 | 3/8 | 1-1/4 | 12.80 | - | - | 1206 | 1266 | 9 |
| 25 x 10 | 26 | 11-1/2 | 8-3/4 | 0.70 | 3-5/8 | 7 | 3/8 | 1-1/4 | 13.20 | - | - | 1256 | 1318 | 9 |
| 26 x 10 | 27 | 11-1/2 | 8-3/4 | 0.70 | 3-7/8 | 7 | 3/8 | 1-1/4 | 13.60 | - | - | 1306 | 1371 | 9 |
| 27 x 10 | 28 | 11-1/2 | 8-3/4 | 0.70 | 3-3/8 | 8 | 3/8 | 1-1/4 | 14.00 | - | - | 1356 | 1424 | 9 |
| 28 x 10 | 29 | 11-1/2 | 8-3/4 | 0.70 | 3-5/8 | 8 | 3/8 | 1-1/4 | 14.50 | - | - | 1400 | 1470 | 9 |

Available upon request - extended lead time required

* Injection molded materials shrink at differing rates. External dimensions may vary. For tight tolerances, contact Maxi-Lift for additional information.

Weights, Dimensions, and Capacities have been estimated from engineered elevator bucket drawings. Actual molded parts will vary from numbers on charts. Please contact Maxi-Lift for the most updated information.

**Reference Punching Chart on page 100.

High Speed Centrifugal Discharge 210 - 900 FPM

TIGER-CC® MAXIMUM DUTY

Standard Profile: Nylon



**NEW SIZES!
ENHANCED
DESIGNS**

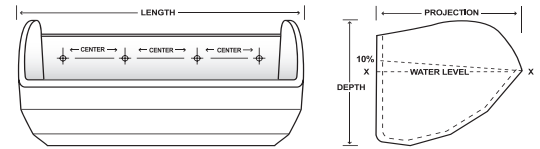

MOUNTING HOLES AND VENTING TO YOUR SPECIFICATIONS

Available Materials:



TIGER-CC® Maximum Duty: Nylon

| BUCKET SIZE, INCHES* | | | | | PUNCHING, IN.** | | | | | WEIGHT, LBS. | CAPACITY, CU. IN. | | |
|----------------------|----------|--------|--------|---------------------|-----------------|------------|-----------|----------|-------|--------------|-------------------|-------------|--|
| BUCKET SIZE | Length** | Proj. | Depth | Back Wall Thickness | Centers | # of Holes | Bolt Size | Top Down | Nylon | Water Level | Water Level +10% | Std Spacing | |
| 12 x 8 | 12-7/8 | 9-1/4 | 8-7/8 | 0.55 | 3-3/8 | 4 | 5/16 | 2 | - | 366 | 403 | 10 | |
| 14 x 8 | 14-7/8 | 9-1/4 | 8-7/8 | 0.55 | 3 | 5 | 5/16 | 2 | - | 430 | 473 | 10 | |
| 16 x 8 | 16-7/8 | 9-1/4 | 8-7/8 | 0.55 | 2-7/8 | 6 | 5/16 | 2 | - | 510 | 561 | 10 | |
| 18 x 8 | 18-7/8 | 9-1/4 | 8-7/8 | 0.55 | 3-1/8 | 6 | 5/16 | 2 | - | 560 | 616 | 10 | |
| 20 x 8 | 20-7/8 | 9-1/4 | 8-7/8 | 0.55 | 3-1/2 | 6 | 5/16 | 2 | 8.15 | 655 | 720 | 10 | |
| 20 x 10 | 21 | 11-1/2 | 10-3/8 | 0.70 | 3-1/2 | 6 | 3/8 | 2-1/4 | - | 1005 | 1106 | 12 | |
| 21 x 10 | 22 | 11-1/2 | 10-3/8 | 0.70 | 3-5/8 | 6 | 3/8 | 2-1/4 | - | 1055 | 1161 | 12 | |
| 22 x 10 | 23 | 11-1/2 | 10-3/8 | 0.70 | 4 | 6 | 3/8 | 2-1/4 | - | 1105 | 1216 | 12 | |
| 23 x 10 | 24 | 11-1/2 | 10-3/8 | 0.70 | 3-3/8 | 7 | 3/8 | 2-1/4 | - | 1155 | 1271 | 12 | |
| 24 x 10 | 25 | 11-1/2 | 10-3/8 | 0.70 | 3-1/2 | 7 | 3/8 | 2-1/4 | - | 1206 | 1327 | 12 | |
| 25 x 10 | 26 | 11-1/2 | 10-3/8 | 0.70 | 3-5/8 | 7 | 3/8 | 2-1/4 | - | 1256 | 1381 | 12 | |
| 26 x 10 | 27 | 11-1/2 | 10-3/8 | 0.70 | 3-7/8 | 7 | 3/8 | 2-1/4 | - | 1306 | 1437 | 12 | |
| 27 x 10 | 28 | 11-1/2 | 10-3/8 | 0.70 | 3-3/8 | 8 | 3/8 | 2-1/4 | - | 1356 | 1492 | 12 | |
| 28 x 10 | 29 | 11-1/2 | 10-3/8 | 0.70 | 3-5/8 | 8 | 3/8 | 2-1/4 | - | 1400 | 1540 | 12 | |

Available upon request - extended lead time required.

* Injection molded materials shrink at differing rates. External dimensions may vary. For tight tolerances, contact Maxi-Lift for additional information. **Some sizes are made to order.

Weights, Dimensions, and Capacities have been estimated from engineered elevator bucket drawings. Actual molded parts will vary from numbers on charts. Please contact Maxi-Lift for the most updated information.

**Reference Punching Chart on page 100.

High Speed Centrifugal Discharge 210 - 900 FPM

TIGER-CC® MAXIMUM DUTY

Standard Profile: Urethane

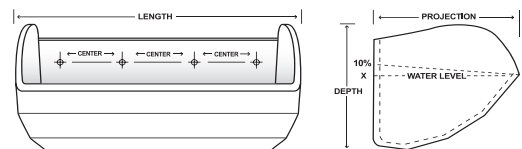

MOUNTING HOLES AND VENTING TO YOUR SPECIFICATIONS

Available Materials:

TIGER-CC® Maximum Duty: Urethane

| BUCKET SIZE, INCHES* | | | | | PUNCHING, IN.** | | | | WEIGHT, LBS. | CAPACITY, CU. IN. | | |
|----------------------|--------|--------|--------|---------------------|-----------------|------------|-----------|----------|--------------|-------------------|------------------|-------------|
| BUCKET SIZE | Length | Proj. | Depth | Back Wall Thickness | Centers | # of Holes | Bolt Size | Top Down | Urethane | Water Level | Water Level +10% | Std Spacing |
| 12 x 8 | 12-7/8 | 9-1/4 | 8-7/8 | 0.55 | 3-3/8 | 4 | 5/16 | 2 | - | 366 | 403 | 10 |
| 14 x 8 | 14-7/8 | 9-1/4 | 8-7/8 | 0.55 | 3 | 5 | 5/16 | 2 | - | 430 | 473 | 10 |
| 16 x 8 | 16-7/8 | 9-1/4 | 8-7/8 | 0.55 | 2-7/8 | 6 | 5/16 | 2 | - | 510 | 561 | 10 |
| 18 x 8 | 18-7/8 | 9-1/4 | 8-7/8 | 0.55 | 3-1/8 | 6 | 5/16 | 2 | - | 560 | 616 | 10 |
| 20 x 8 | 20-7/8 | 9-1/4 | 8-7/8 | 0.55 | 3-1/2 | 6 | 5/16 | 2 | 9.58 | 655 | 720 | 10 |
| 20 x 10 | 21 | 11-1/2 | 10-3/8 | 0.70 | 3-1/2 | 6 | 3/8 | 2-1/4 | - | 1005 | 1106 | 12 |

* Injection molded materials shrink at differing rates. External dimensions may vary. For tight tolerances, contact Maxi-Lift for additional information. **Some sizes are made to order. Weights, Dimensions, and Capacities have been estimated from engineered elevator bucket drawings. Actual molded parts will vary from numbers on charts. Please contact Maxi-Lift for the most updated information. **Reference Punching Chart on page 100.

OTHER CONSIDERATIONS

- DRILLING:** Elevator buckets are manufactured without a drill pattern. Special drilling or punching can be accommodated upon customer request.
- VENTING:** Available as needed. See venting options in this catalog.
- DIGGER BUCKETS:** Use slightly larger metal digger elevator buckets to help loosen material in the elevator boot section that has set up or hardened, thereby reducing abrasion on the plastic buckets. Call for details on Metal Digger elevator bucket options.
- SPACING:** See elevator bucket spacing details in the size chart (depending on materials and speeds, smaller and larger spacing may be used).
- INSTALLATION:** Use a #1 standard elevator bolt or Sabre-Tooth elevator bolt for installation. Designed to be used with fender or flat and lock washers and hex or locking nuts. If buckets are being installed on chain, use hex head bolts, nuts and washers.
- ADAPTER PLATES:** Recommended for chain mounting applications.
- FDA:** Both the urethane and polyethylene are designed to FDA specifications for direct contact with food products.

High Speed Centrifugal Discharge 210 - 900 FPM

HD-MAX® HEAVY DUTY

High Speed Centrifugal Discharge 210 - 900 FPM

THE MAXI-LIFT HD-MAX



UPGRADE TO THE BUCKET THAT DEFINES "HEAVY DUTY"

HIGHER CAPACITY MEANS HD-MAX:
THE HD-MAX WILL HELP YOU ELEVATE MORE MATERIAL FASTER TO MEET YOUR HIGHER CAPACITY DEMANDS.

ENGINEERED WITH THICKER FRONT LIP:
WHEN BUCKET WEAR IS AN ISSUE, THE HD-MAX GIVES YOU LONGER LIFE AT A MORE ECONOMICAL PRICE.

PERFORMANCE BY DESIGN:
LOW SIDES AND SMOOTH BOTTOM GIVE EXCELLENT CUP FILL & DISCHARGE.

FEATURES & BENEFITS

- Thicker Walls, Heavy Front Lip for Digging
- High Impact & Abrasion Resistant
- Non-Corrosive, Non-Sparking
- Extends Bucket Life
- Increases Elevator Capacity
- Cleaner Discharge
- Lowers Elevator Maintenance
- Decreases Elevator Down Time



© The color red, as applied to buckets, is a registered trademark of Maxi-Lift, Inc.

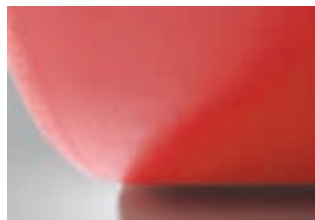

Heavy Duty Construction



Reinforced Side Walls



Reinforced Corners



Heavy Front Lip

HD-MAX® HEAVY DUTY

High Speed Centrifugal Discharge 210 - 900 FPM



HD-MAX® HEAVY DUTY: STANDARD PROFILE

The **HD-MAX** Heavy Duty elevator bucket is engineered to exceed the performance requirements of the standard bucket. This bucket is designed with thicker walls and a reinforced front lip to increase bucket life and reduce breakage. Replacing existing Standard Duty buckets with the **HD-MAX** will create longer bucket life and less frequent replacements. Standard spacing is nominal projection + 2". The most common applications include grain, fertilizer, pellets, corn, wheat, soybeans and other agricultural applications. The **HD-MAX** bucket stands second to the **TIGER-TUFF** in strength and thickness.

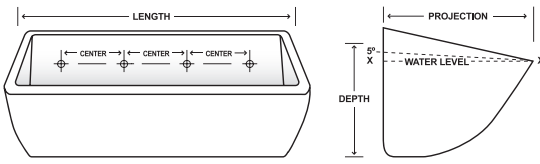

HD-MAX® HEAVY DUTY: LOW PROFILE

The **HD-MAX** Low Profile bucket has a reduced height modification for closer vertical spacing on the belt. The low profile system allows more buckets per foot of elevator belt. When upgrading to **HD-MAX Heavy Duty Low Profile** buckets, horsepower requirements must be evaluated due to increased capacity.

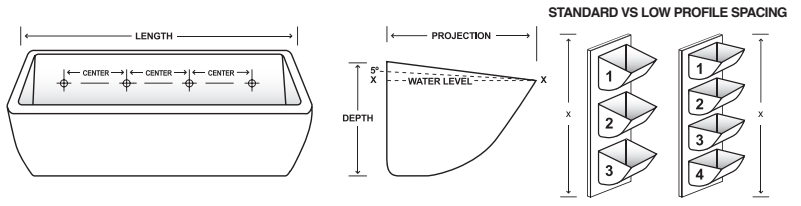

AVAILABLE MATERIALS

| | POLYETHYLENE | NYLON | URETHANE | FDA NYLON |
|------------------------------|--|--|---|---|
| Color | Red, White | Tan | Green | White |
| Application | Grain & Food Products | Hot, high impact, abrasive dense products | Heavy abrasion, sticky materials | Hot, high impact, abrasive food grade products |
| Temperature Range | -120° F to + 180° F (210° F Intermittent) | -60° F to + 300° F (350° F Intermittent) | -60° F to + 180° F (210° F Intermittent) | -60° F to + 300° F |
| FDA Approved Material | Yes | No | Yes | Yes |
| Comments | Economical, high density polyethylene. FDA approved material for handling food grade products. | Best for high heat applications, with tough impact and abrasion needs. | Most flexible and abrasion resistant. Resists product sticking and sharp cutting particles. | Best for high heat food grade applications, with tough impact and abrasion needs. |

APPLICATIONS



FOOD
Barley, Beans, Corn, Cotton Seed, Coffee, Flour, Grains, Nuts, Rice, Sunflower, Oats, Salt, Sugar, Wheat, etc.



FEED
Bone Meal, Pellets, Meat Scrap, etc.



OTHER
Seeds, Grass Seed, Fertilizer, Perlite, Potash, Sawdust, Minerals, etc.

HD-MAX® HEAVY DUTY

Standard Profile: Polyethylene



® The color red, as applied to buckets, is a registered trademark of Maxi-Lift, Inc.

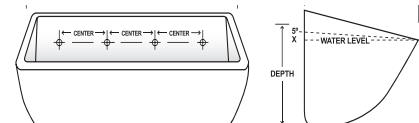

MOUNTING HOLES AND VENTING TO YOUR SPECIFICATIONS

HD-MAX® Heavy Duty: Polyethylene

Available Materials:

| BUCKET SIZE, INCHES* | | | | | PUNCHING, IN.** | | | | WEIGHT, LBS. | CAPACITY, CU. IN. | | |
|----------------------|--------|--------|-------|---------------------|-----------------|------------|-----------|----------|--------------|-------------------|---------------|-------------|
| BUCKET SIZE | Length | Proj. | Depth | Back Wall Thickness | Centers | # Of Holes | Bolt Size | Top Down | HDPE | Water Level | Usable 5 Deg. | Std Spacing |
| 3 x 2 | 3-1/4 | 2-5/16 | 2 1/4 | 0.17 | 1-3/4 | 2 | 1/4 | 7/8 | 0.12 | 6.71 | 7.93 | 4 |
| 4 x 3 | 4-3/8 | 3-1/4 | 3 | 0.17 | 2-1/4 | 2 | 1/4 | 7/8 | 0.22 | 15.26 | 17.70 | 5 |
| 5 x 4 | 5-1/4 | 4-1/2 | 4 | 0.30 | 3-3/16 | 2 | 1/4 | 1-1/8 | 0.47 | 36.20 | 39.82 | 6 |
| 6 x 4 | 6-1/4 | 4-1/2 | 4 | 0.30 | 4-3/8 | 2 | 1/4 | 1-1/8 | 0.56 | 44.20 | 49.58 | 6 |
| 7 x 4 | 7-1/4 | 4-1/2 | 4 | 0.30 | 2-5/8 | 3 | 1/4 | 1-1/8 | 0.66 | 51.31 | 57.01 | 6 |
| 6 x 5 | 6-3/8 | 5-5/8 | 5 | 0.30 | 4-3/8 | 2 | 1/4 | 1-5/8 | 0.88 | 67.20 | 73.98 | 7 |
| 7 x 5 | 7-3/8 | 5-5/8 | 5 | 0.30 | 2-5/8 | 3 | 1/4 | 1-5/8 | 0.98 | 79.72 | 89.24 | 7 |
| 8 x 5 | 8-3/8 | 5-5/8 | 5 | 0.30 | 3-1/16 | 3 | 1/4 | 1-5/8 | 1.15 | 102.85 | 115.85 | 7 |
| 9 x 5 | 9-3/8 | 5-5/8 | 5 | 0.30 | 3-1/2 | 3 | 1/4 | 1-5/8 | 1.20 | 107.37 | 121.27 | 7 |
| 10 x 5 | 10-1/4 | 5-5/8 | 5 | 0.30 | 4 | 3 | 1/4 | 1-5/8 | 1.26 | 121.30 | 138.89 | 7 |
| 11 x 5 | 11-1/4 | 5-5/8 | 5 | 0.30 | 3-1/8 | 4 | 1/4 | 1-5/8 | 1.37 | 140.70 | 153.16 | 7 |
| 12 x 5 | 12-1/4 | 5-5/8 | 5 | 0.30 | 3-3/8 | 4 | 1/4 | 1-5/8 | 1.55 | 159.87 | 167.14 | 7 |
| 8 x 6 | 8-3/8 | 6-5/8 | 6 | 0.30 | 3-1/16 | 3 | 1/4 | 1-5/8 | 1.35 | 135.56 | 150.85 | 8 |
| 9 x 6 | 9-3/8 | 6-5/8 | 6 | 0.30 | 3-1/2 | 3 | 1/4 | 1-5/8 | 1.53 | 150.26 | 165.87 | 8 |
| 10 x 6 | 10-3/8 | 6-5/8 | 6 | 0.30 | 4 | 3 | 1/4 | 1-5/8 | 1.64 | 170.69 | 185.62 | 8 |
| 11 x 6 | 11-3/8 | 6-5/8 | 6 | 0.30 | 3 | 4 | 1/4 | 1-5/8 | 1.82 | 185.18 | 200.36 | 8 |
| 12 x 6 | 12-3/8 | 6-5/8 | 6 | 0.30 | 3-3/8 | 4 | 1/4 | 1-5/8 | 1.89 | 200.37 | 220.58 | 8 |
| 13 x 6 | 13-3/8 | 6-5/8 | 6 | 0.30 | 3-5/8 | 4 | 1/4 | 1-5/8 | 2.04 | 220.78 | 240.48 | 8 |
| 10 x 7 | 10-1/2 | 7-3/4 | 7 1/8 | 0.33 | 4 | 3 | 5/16 | 1-7/8 | 2.35 | 240.91 | 264.59 | 9 |
| 11 x 7 | 11-1/2 | 7-3/4 | 7 1/8 | 0.33 | 3 | 4 | 5/16 | 1-7/8 | 2.55 | 269.32 | 292.41 | 9 |
| 12 x 7 | 12-1/2 | 7-3/4 | 7 1/8 | 0.33 | 3-3/8 | 4 | 5/16 | 1-7/8 | 2.73 | 292.41 | 319.63 | 9 |
| 13 x 7 | 13-1/2 | 7-3/4 | 7 1/8 | 0.33 | 3-5/8 | 4 | 5/16 | 1-7/8 | 2.89 | 344.20 | 356.40 | 9 |
| 14 x 7 | 14-1/2 | 7-3/4 | 7 1/8 | 0.33 | 3 | 5 | 5/16 | 1-7/8 | 3.10 | 356.40 | 389.90 | 9 |
| 15 x 7 | 15-1/2 | 7-3/4 | 7 1/8 | 0.33 | 3-1/4 | 5 | 5/16 | 1-7/8 | 3.23 | 379.50 | 408.20 | 9 |
| 16 x 7 | 16-1/2 | 7-3/4 | 7 1/8 | 0.33 | 3-1/2 | 5 | 5/16 | 1-7/8 | 3.37 | 406.40 | 432.00 | 9 |
| 10 x 8 | 10-1/2 | 8-3/4 | 8 | 0.40 | 4-1/8 | 3 | 5/16 | 2 | 2.89 | 328.52 | 353.97 | 10 |
| 11 x 8 | 11-1/2 | 8-3/4 | 8 | 0.40 | 3-1/8 | 4 | 5/16 | 2 | 3.17 | 358.11 | 388.30 | 10 |
| 12 x 8 | 12-1/2 | 8-3/4 | 8 | 0.40 | 3-3/8 | 4 | 5/16 | 2 | 3.46 | 390.67 | 423.22 | 10 |
| 14 x 8 | 14-1/2 | 8-3/4 | 8 | 0.40 | 3 | 5 | 5/16 | 2 | 3.86 | 465.00 | 502.80 | 10 |
| 15 x 8 | 15-1/2 | 8-3/4 | 8 | 0.40 | 3-1/4 | 5 | 5/16 | 2 | 4.06 | 511.30 | 541.90 | 10 |
| 16 x 8 | 16-1/2 | 8-3/4 | 8 | 0.40 | 3-1/2 | 5 | 5/16 | 2 | 4.26 | 543.10 | 571.10 | 10 |
| 18 x 8 | 18-1/2 | 8-3/4 | 8 | 0.40 | 3-1/8 | 6 | 5/16 | 2 | 4.66 | 610.20 | 648.00 | 10 |

* Injection molded materials shrink at differing rates. External dimensions may vary. For tight tolerances, contact Maxi-Lift for additional information. **Reference Punching Chart on page 100.

■ - Indicates HD-MAX and CC-MAX punch patterns differ.

High Speed Centrifugal Discharge 210 - 900 FPM

HD-MAX® HEAVY DUTY

Low Profile: Polyethylene, Nylon, Urethane

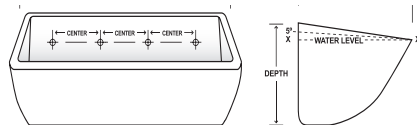
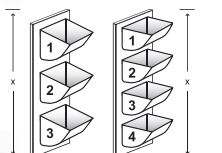

® The color red, as applied to buckets, is a registered trademark of Maxi-Lift, Inc.

STANDARD VS LOW PROFILE SPACING

MOUNTING HOLES AND VENTING TO YOUR SPECIFICATIONS

HD-MAX® Heavy Duty Low Profile

Available Materials:



| BUCKET SIZE, INCHES* | | | | | PUNCHING, IN.** | | | | WEIGHT, LBS. | | | CAPACITY, CU. IN. | | |
|----------------------|--------|--------|-------|---------------------|-----------------|------------|-----------|----------|--------------|-------|------|-------------------|---------------|-------------|
| BUCKET SIZE | Length | Proj. | Depth | Back Wall Thickness | Centers | # Of Holes | Bolt Size | Top Down | HDPE | Nylon | Uret | Water Level | Usable 5 Deg. | Std Spacing |
| 3 x 2 | 3-1/4 | 2-5/16 | 2-1/4 | 0.17 | 1-3/4 | 2 | 1/4 | 1 | 0.11 | 0.13 | 0.15 | 6.71 | 7.93 | 2-1/4 |
| 4 x 3 | 4-3/8 | 3-1/4 | 2-3/4 | 0.17 | 2-1/4 | 2 | 1/4 | 1 | 0.19 | 0.22 | 0.29 | 15.26 | 17.70 | 2-3/4 |
| 5 x 4 | 5-1/4 | 4-1/2 | 3-1/4 | 0.30 | 3-3/16 | 2 | 1/4 | 1 | 0.42 | 0.49 | 0.65 | 36.20 | 39.82 | 3-1/4 |
| 6 x 4 | 6-1/4 | 4-1/2 | 3-1/2 | 0.30 | 4-3/8 | 2 | 1/4 | 1 | 0.49 | 0.57 | 0.73 | 44.20 | 49.58 | 3-1/2 |
| 7 x 4 | 7-1/4 | 4-1/2 | 3-1/2 | 0.30 | 2-5/8 | 3 | 1/4 | 1 | 0.57 | 0.66 | 0.86 | 51.31 | 57.01 | 3-1/2 |
| 6 x 5 | 6-3/8 | 5-5/8 | 4 | 0.30 | 4-3/8 | 2 | 1/4 | 1 | 0.67 | 0.76 | 0.91 | 67.20 | 73.98 | 4 |
| 7 x 5 | 7-3/8 | 5-5/8 | 4 | 0.30 | 2-5/8 | 3 | 1/4 | 1 | 0.72 | 0.84 | 1.09 | 79.72 | 89.24 | 4 |
| 8 x 5 | 8-3/8 | 5-5/8 | 4 | 0.30 | 3-1/16 | 3 | 1/4 | 1 | 1.09 | 0.87 | 1.15 | 102.85 | 115.85 | 4 |
| 9 x 5 | 9-3/8 | 5-5/8 | 4 | 0.30 | 3-1/2 | 3 | 1/4 | 1 | 1.14 | 1.15 | 1.35 | 107.37 | 121.27 | 4 |
| 10 x 5 | 10-1/4 | 5-5/8 | 4-1/2 | 0.30 | 4 | 3 | 1/4 | 1 | 1.18 | 1.37 | 1.70 | 121.30 | 138.89 | 4-1/2 |
| 11 x 5 | 11-1/4 | 5-5/8 | 4-1/2 | 0.30 | 3-1/8 | 4 | 1/4 | 1 | 1.24 | 1.44 | 1.82 | 140.70 | 153.16 | 4-1/2 |
| 12 x 5 | 12-1/4 | 5-5/8 | 4-1/2 | 0.30 | 3-3/8 | 4 | 1/4 | 1 | 1.32 | 1.53 | 2.06 | 159.87 | 167.14 | 4-1/2 |
| 8 x 6 | 8-3/8 | 6-5/8 | 5 | 0.30 | 3-1/16 | 3 | 1/4 | 1 | 1.24 | 1.41 | 1.70 | 135.56 | 150.85 | 5 |
| 9 x 6 | 9-3/8 | 6-5/8 | 5 | 0.30 | 3-1/2 | 3 | 1/4 | 1 | 1.39 | 1.59 | 1.91 | 150.26 | 165.87 | 5 |
| 10 x 6 | 10-3/8 | 6-5/8 | 5 | 0.30 | 4 | 3 | 1/4 | 1 | 1.48 | 1.68 | 2.02 | 170.69 | 185.62 | 5 |
| 11 x 6 | 11-3/8 | 6-5/8 | 5 | 0.30 | 3 | 4 | 1/4 | 1 | 1.66 | 1.89 | 2.28 | 185.18 | 200.36 | 5 |
| 12 x 6 | 12-3/8 | 6-5/8 | 5 | 0.30 | 3-3/8 | 4 | 1/4 | 1 | 1.73 | 1.96 | 2.36 | 200.37 | 220.58 | 5 |
| 13 x 6 | 13-3/8 | 6-5/8 | 5 | 0.30 | 3-5/8 | 4 | 1/4 | 1 | 1.86 | 2.12 | 2.55 | 220.78 | 240.48 | 5 |
| 10 x 7 | 10-1/2 | 7-3/4 | 6 | 0.33 | 4 | 3 | 5/16 | 1 | 2.17 | 2.47 | 2.97 | 240.91 | 264.59 | 6 |
| 11 x 7 | 11-1/2 | 7-3/4 | 6 | 0.33 | 3 | 4 | 5/16 | 1 | 2.32 | 2.64 | 3.18 | 269.32 | 292.41 | 6 |
| 12 x 7 | 12-1/2 | 7-3/4 | 6 | 0.33 | 3-3/8 | 4 | 5/16 | 1 | 2.54 | 2.90 | 3.48 | 292.41 | 319.63 | 6 |
| 13 x 7 | 13-1/2 | 7-3/4 | 6 | 0.33 | 3-5/8 | 4 | 5/16 | 1 | 2.63 | 3.02 | 3.55 | 344.20 | 356.40 | 6 |
| 14 x 7 | 14-1/2 | 7-3/4 | 6 | 0.33 | 3 | 5 | 5/16 | 1 | 2.85 | 3.28 | 3.85 | 356.40 | 389.90 | 6 |
| 15 x 7 | 15-1/2 | 7-3/4 | 6 | 0.33 | 3-1/4 | 5 | 5/16 | 1 | 3.01 | 3.46 | 4.06 | 379.50 | 408.20 | 6 |
| 16 x 7 | 16-1/2 | 7-3/4 | 6 | 0.33 | 3-1/2 | 5 | 5/16 | 1 | 3.12 | 3.59 | 4.21 | 406.40 | 432.00 | 6 |
| 10 x 8 | 10-1/2 | 8-3/4 | 6 | 0.40 | 4-1/8 | 3 | 5/16 | 1 | 2.58 | 2.94 | 3.53 | 328.52 | 353.97 | 7 |
| 11 x 8 | 11-1/2 | 8-3/4 | 6-3/4 | 0.40 | 3-1/8 | 4 | 5/16 | 1 | 2.85 | 3.25 | 3.90 | 358.11 | 388.30 | 7 |
| 12 x 8 | 12-1/2 | 8-3/4 | 6-3/4 | 0.40 | 3-3/8 | 4 | 5/16 | 1 | 3.15 | 3.59 | 4.32 | 390.67 | 423.22 | 7 |
| 14 x 8 | 14-1/2 | 8-3/4 | 6-3/4 | 0.40 | 3 | 5 | 5/16 | 1 | 3.51 | 4.04 | 4.74 | 465.00 | 502.80 | 7 |
| 15 x 8 | 15-1/2 | 8-3/4 | 6-3/4 | 0.40 | 3-1/4 | 5 | 5/16 | 1 | 3.67 | 4.22 | 4.95 | 511.30 | 541.90 | 7 |
| 16 x 8 | 16-1/2 | 8-3/4 | 6-3/4 | 0.40 | 3-1/2 | 5 | 5/16 | 1 | 3.79 | 4.36 | 5.12 | 543.10 | 571.10 | 7 |
| 18 x 8 | 18-1/2 | 8-3/4 | 6-3/4 | 0.40 | 3-1/8 | 6 | 5/16 | 1 | 4.24 | 4.88 | 5.72 | 610.20 | 648.00 | 7 |

* Injection molded materials shrink at differing rates. External dimensions may vary. For tight tolerances, contact Maxi-Lift for additional information. **Reference Punching Chart on page 100.

■ - Indicates HD-MAX and CC-MAX punch patterns differ.

High Speed Centrifugal Discharge 210 - 900 FPM

HD-MAX® HEAVY DUTY

Standard Profile: Nylon

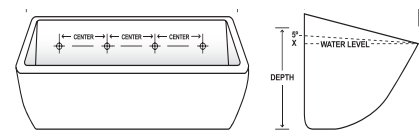

MOUNTING HOLES AND VENTING TO YOUR SPECIFICATIONS

HD-MAX® Heavy Duty: Nylon

Available Materials:

| BUCKET SIZE, INCHES* | | | | | PUNCHING, IN.** | | | | WEIGHT, LBS. | CAPACITY, CU. IN. | | |
|----------------------|--------|--------|-------|---------------------|-----------------|------------|-----------|----------|--------------|-------------------|---------------|-------------|
| BUCKET SIZE | Length | Proj. | Depth | Back Wall Thickness | Centers | # Of Holes | Bolt Size | Top Down | Nylon | Water Level | Usable 5 Deg. | Std Spacing |
| 3 x 2 | 3-1/4 | 2-5/16 | 2 1/4 | 0.17 | 1-3/4 | 2 | 1/4 | 7/8 | 0.15 | 6.71 | 7.93 | 4 |
| 4 x 3 | 4-3/8 | 3-1/4 | 3 | 0.17 | 2-1/4 | 2 | 1/4 | 7/8 | 0.25 | 15.26 | 17.70 | 5 |
| 5 x 4 | 5-1/4 | 4-1/2 | 4 | 0.30 | 3-3/16 | 2 | 1/4 | 1-1/8 | 0.60 | 36.20 | 39.82 | 6 |
| 6 x 4 | 6-1/4 | 4-1/2 | 4 | 0.30 | 4-3/8 | 2 | 1/4 | 1-1/8 | 0.70 | 44.20 | 49.58 | 6 |
| 7 x 4 | 7-1/4 | 4-1/2 | 4 | 0.30 | 2-5/8 | 3 | 1/4 | 1-1/8 | 0.80 | 51.31 | 57.01 | 6 |
| 6 x 5 | 6-3/8 | 5-5/8 | 5 | 0.30 | 4-3/8 | 2 | 1/4 | 1-5/8 | 0.85 | 67.20 | 73.98 | 7 |
| 7 x 5 | 7-3/8 | 5-5/8 | 5 | 0.30 | 2-5/8 | 3 | 1/4 | 1-5/8 | 0.95 | 79.72 | 89.24 | 7 |
| 8 x 5 | 8-3/8 | 5-5/8 | 5 | 0.30 | 3-1/16 | 3 | 1/4 | 1-5/8 | 1.30 | 102.85 | 115.85 | 7 |
| 9 x 5 | 9-3/8 | 5-5/8 | 5 | 0.30 | 3-1/2 | 3 | 1/4 | 1-5/8 | 1.20 | 107.37 | 121.27 | 7 |
| 10 x 5 | 10-1/4 | 5-5/8 | 5 | 0.30 | 4 | 3 | 1/4 | 1-5/8 | 1.40 | 121.30 | 138.89 | 7 |
| 11 x 5 | 11-1/4 | 5-5/8 | 5 | 0.30 | 3-1/8 | 4 | 1/4 | 1-5/8 | 1.55 | 140.70 | 153.16 | 7 |
| 12 x 5 | 12-1/4 | 5-5/8 | 5 | 0.30 | 3-3/8 | 4 | 1/4 | 1-5/8 | 1.70 | 159.87 | 167.14 | 7 |
| 8 x 6 | 8-3/8 | 6-5/8 | 6 | 0.30 | 3-1/16 | 3 | 1/4 | 1-5/8 | 1.65 | 135.56 | 150.85 | 8 |
| 9 x 6 | 9-3/8 | 6-5/8 | 6 | 0.30 | 3-1/2 | 3 | 1/4 | 1-5/8 | 1.75 | 150.26 | 165.87 | 8 |
| 10 x 6 | 10-3/8 | 6-5/8 | 6 | 0.30 | 4 | 3 | 1/4 | 1-5/8 | 1.85 | 170.69 | 185.62 | 8 |
| 11 x 6 | 11-3/8 | 6-5/8 | 6 | 0.30 | 3 | 4 | 1/4 | 1-5/8 | 2.05 | 185.18 | 200.36 | 8 |
| 12 x 6 | 12-3/8 | 6-5/8 | 6 | 0.30 | 3-3/8 | 4 | 1/4 | 1-5/8 | 2.15 | 200.37 | 220.58 | 8 |
| 13 x 6 | 13-3/8 | 6-5/8 | 6 | 0.30 | 3-5/8 | 4 | 1/4 | 1-5/8 | 2.35 | 220.78 | 240.48 | 8 |
| 10 x 7 | 10-1/2 | 7-3/4 | 7 1/8 | 0.33 | 4 | 3 | 5/16 | 1-7/8 | 2.68 | 240.91 | 264.59 | 9 |
| 11 x 7 | 11-1/2 | 7-3/4 | 7 1/8 | 0.33 | 3 | 4 | 5/16 | 1-7/8 | 2.85 | 269.32 | 292.41 | 9 |
| 12 x 7 | 12-1/2 | 7-3/4 | 7 1/8 | 0.33 | 3-3/8 | 4 | 5/16 | 1-7/8 | 3.20 | 292.41 | 319.63 | 9 |
| 13 x 7 | 13-1/2 | 7-3/4 | 7 1/8 | 0.33 | 3-5/8 | 4 | 5/16 | 1-7/8 | 3.25 | 344.20 | 356.40 | 9 |
| 14 x 7 | 14-1/2 | 7-3/4 | 7 1/8 | 0.33 | 3 | 5 | 5/16 | 1-7/8 | 3.45 | 356.40 | 389.90 | 9 |
| 15 x 7 | 15-1/2 | 7-3/4 | 7 1/8 | 0.33 | 3-1/4 | 5 | 5/16 | 1-7/8 | 3.71 | 379.50 | 408.20 | 9 |
| 16 x 7 | 16-1/2 | 7-3/4 | 7 1/8 | 0.33 | 3-1/2 | 5 | 5/16 | 1-7/8 | 3.90 | 406.40 | 432.00 | 9 |
| 10 x 8 | 10-1/2 | 8-3/4 | 8 | 0.40 | 4-1/8 | 3 | 5/16 | 2 | 3.29 | 328.52 | 353.97 | 10 |
| 11 x 8 | 11-1/2 | 8-3/4 | 8 | 0.40 | 3-1/8 | 4 | 5/16 | 2 | 3.55 | 358.11 | 388.30 | 10 |
| 12 x 8 | 12-1/2 | 8-3/4 | 8 | 0.40 | 3-3/8 | 4 | 5/16 | 2 | 4.00 | 390.67 | 423.22 | 10 |
| 14 x 8 | 14-1/2 | 8-3/4 | 8 | 0.40 | 3 | 5 | 5/16 | 2 | 4.35 | 465.00 | 502.80 | 10 |
| 15 x 8 | 15-1/2 | 8-3/4 | 8 | 0.40 | 3-1/4 | 5 | 5/16 | 2 | 4.67 | 511.30 | 541.90 | 10 |
| 16 x 8 | 16-1/2 | 8-3/4 | 8 | 0.40 | 3-1/2 | 5 | 5/16 | 2 | 4.70 | 543.10 | 571.10 | 10 |
| 18 x 8 | 18-1/2 | 8-3/4 | 8 | 0.40 | 3-1/8 | 6 | 5/16 | 2 | 5.10 | 610.20 | 648.00 | 10 |

* Injection molded materials shrink at differing rates. External dimensions may vary. For tight tolerances, contact Maxi-Lift for additional information. **Reference Punching Chart on page 100.

■ - Indicates HD-MAX and CC-MAX punch patterns differ.

OTHER CONSIDERATIONS

ENGINEERING: Please see Section 5 of catalog for detailed engineering, speed and capacity information.

DRILLING: Elevator Buckets are manufactured without a drill pattern. Special drilling or punching can be accommodated upon customer request.

*Mounting Holes drilled 1/32 to 1/16 over bolt diameter for easier installation.

VENTING: Available as needed. See venting options in this catalog.

DIGGER BUCKETS: Use slightly larger metal digger elevator buckets to help loosen material in the elevator boot section that has set up or hardened thereby reducing abrasion on the plastic buckets. Call for details on Metal Digger elevator bucket options.

HD-MAX® HEAVY DUTY

Standard Profile: Urethane

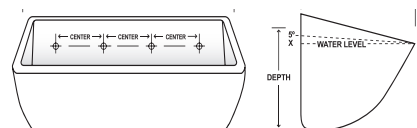

MOUNTING HOLES AND VENTING TO YOUR SPECIFICATIONS

HD-MAX® Heavy Duty: Urethane

Available Materials:



| BUCKET SIZE, INCHES* | | | | | PUNCHING, IN.** | | | | WEIGHT, LBS. | CAPACITY, CU. IN. | | |
|----------------------|--------|--------|-------|---------------------|-----------------|------------|-----------|----------|--------------|-------------------|---------------|-------------|
| BUCKET SIZE | Length | Proj. | Depth | Back Wall Thickness | Centers | # Of Holes | Bolt Size | Top Down | Uret | Water Level | Usable 5 Deg. | Std Spacing |
| 3 x 2 | 3-1/4 | 2-5/16 | 2 1/4 | 0.17 | 1-3/4 | 2 | 1/4 | 7/8 | 0.20 | 6.71 | 7.93 | 4 |
| 4 x 3 | 4-3/8 | 3-1/4 | 3 | 0.17 | 2-1/4 | 2 | 1/4 | 7/8 | 0.30 | 15.26 | 17.70 | 5 |
| 5 x 4 | 5-1/4 | 4-1/2 | 4 | 0.30 | 3-3/16 | 2 | 1/4 | 1-1/8 | 0.75 | 36.20 | 39.82 | 6 |
| 6 x 4 | 6-1/4 | 4-1/2 | 4 | 0.30 | 4-3/8 | 2 | 1/4 | 1-1/8 | 0.85 | 44.20 | 49.58 | 6 |
| 7 x 4 | 7-1/4 | 4-1/2 | 4 | 0.30 | 2-5/8 | 3 | 1/4 | 1-1/8 | 0.88 | 51.31 | 57.01 | 6 |
| 6 x 5 | 6-3/8 | 5-5/8 | 5 | 0.30 | 4-3/8 | 2 | 1/4 | 1-5/8 | 1.00 | 67.20 | 73.98 | 7 |
| 7 x 5 | 7-3/8 | 5-5/8 | 5 | 0.30 | 2-5/8 | 3 | 1/4 | 1-5/8 | 1.15 | 79.72 | 89.24 | 7 |
| 8 x 5 | 8-3/8 | 5-5/8 | 5 | 0.30 | 3-1/16 | 3 | 1/4 | 1-5/8 | 1.55 | 102.85 | 115.85 | 7 |
| 9 x 5 | 9-3/8 | 5-5/8 | 5 | 0.30 | 3-1/2 | 3 | 1/4 | 1-5/8 | 1.40 | 107.37 | 121.27 | 7 |
| 10 x 5 | 10-1/4 | 5-5/8 | 5 | 0.30 | 4 | 3 | 1/4 | 1-5/8 | 1.70 | 121.30 | 138.89 | 7 |
| 11 x 5 | 11-1/4 | 5-5/8 | 5 | 0.30 | 3-1/8 | 4 | 1/4 | 1-5/8 | 1.85 | 140.70 | 153.16 | 7 |
| 12 x 5 | 12-1/4 | 5-5/8 | 5 | 0.30 | 3-3/8 | 4 | 1/4 | 1-5/8 | 2.12 | 159.87 | 167.14 | 7 |
| 8 x 6 | 8-3/8 | 6-5/8 | 6 | 0.30 | 3-1/16 | 3 | 1/4 | 1-5/8 | 1.95 | 135.56 | 150.85 | 8 |
| 9 x 6 | 9-3/8 | 6-5/8 | 6 | 0.30 | 3-1/2 | 3 | 1/4 | 1-5/8 | 2.10 | 150.26 | 165.87 | 8 |
| 10 x 6 | 10-3/8 | 6-5/8 | 6 | 0.30 | 4 | 3 | 1/4 | 1-5/8 | 2.30 | 170.69 | 185.62 | 8 |
| 11 x 6 | 11-3/8 | 6-5/8 | 6 | 0.30 | 3 | 4 | 1/4 | 1-5/8 | 2.45 | 185.18 | 200.36 | 8 |
| 12 x 6 | 12-3/8 | 6-5/8 | 6 | 0.30 | 3-3/8 | 4 | 1/4 | 1-5/8 | 2.65 | 200.37 | 220.58 | 8 |
| 13 x 6 | 13-3/8 | 6-5/8 | 6 | 0.30 | 3-5/8 | 4 | 1/4 | 1-5/8 | 2.85 | 220.78 | 240.48 | 8 |
| 10 x 7 | 10-1/2 | 7-3/4 | 7 1/8 | 0.33 | 4 | 3 | 5/16 | 1-7/8 | 3.25 | 240.91 | 264.59 | 9 |
| 11 x 7 | 11-1/2 | 7-3/4 | 7 1/8 | 0.33 | 3 | 4 | 5/16 | 1-7/8 | 3.45 | 269.32 | 292.41 | 9 |
| 12 x 7 | 12-1/2 | 7-3/4 | 7 1/8 | 0.33 | 3-3/8 | 4 | 5/16 | 1-7/8 | 3.80 | 292.41 | 319.63 | 9 |
| 13 x 7 | 13-1/2 | 7-3/4 | 7 1/8 | 0.33 | 3-5/8 | 4 | 5/16 | 1-7/8 | 3.85 | 344.20 | 356.40 | 9 |
| 14 x 7 | 14-1/2 | 7-3/4 | 7 1/8 | 0.33 | 3 | 5 | 5/16 | 1-7/8 | 4.25 | 356.40 | 389.90 | 9 |
| 15 x 7 | 15-1/2 | 7-3/4 | 7 1/8 | 0.33 | 3-1/4 | 5 | 5/16 | 1-7/8 | 4.36 | 379.50 | 408.20 | 9 |
| 16 x 7 | 16-1/2 | 7-3/4 | 7 1/8 | 0.33 | 3-1/2 | 5 | 5/16 | 1-7/8 | 4.60 | 406.40 | 432.00 | 9 |
| 10 x 8 | 10-1/2 | 8-3/4 | 8 | 0.40 | 4-1/8 | 3 | 5/16 | 2 | 4.10 | 328.52 | 353.97 | 10 |
| 11 x 8 | 11-1/2 | 8-3/4 | 8 | 0.40 | 3-1/8 | 4 | 5/16 | 2 | 4.34 | 358.11 | 388.30 | 10 |
| 12 x 8 | 12-1/2 | 8-3/4 | 8 | 0.40 | 3-3/8 | 4 | 5/16 | 2 | 4.65 | 390.67 | 423.22 | 10 |
| 14 x 8 | 14-1/2 | 8-3/4 | 8 | 0.40 | 3 | 5 | 5/16 | 2 | 5.30 | 465.00 | 502.80 | 10 |
| 15 x 8 | 15-1/2 | 8-3/4 | 8 | 0.40 | 3-1/4 | 5 | 5/16 | 2 | 5.55 | 511.30 | 541.90 | 10 |
| 16 x 8 | 16-1/2 | 8-3/4 | 8 | 0.40 | 3-1/2 | 5 | 5/16 | 2 | 5.60 | 543.10 | 571.10 | 10 |
| 18 x 8 | 18-1/2 | 8-3/4 | 8 | 0.40 | 3-1/8 | 6 | 5/16 | 2 | 6.10 | 610.20 | 648.00 | 10 |

* Injection molded materials shrink at differing rates. External dimensions may vary. For tight tolerances, contact Maxi-Lift for additional information. **Reference Punching Chart on page 100.

■ - Indicates HD-MAX and CC-MAX punch patterns differ.

SPACING: See elevator bucket spacing details in the HD-MAX chart (depending on materials and speeds, smaller and larger spacing may be used).

INSTALLATION: Use a #1 standard elevator bolt or Sabre-Tooth elevator bolt for installation. Designed to be used with fender or flat and lock washers and hex or locking nuts. If buckets are being installed on chain, use hex head bolts, nuts and washers. A locking device should always be used.

ADAPTER PLATES: Recommended for chain mounting applications.

FDA: Both the urethane and polyethylene are designed to FDA specifications for direct contact with food products.

USABLE CAPACITY: Under normal usage, the HD-MAX plastic elevator bucket will carry and deliver +5° of the water level cubic inch capacity. Maxi-Lift recommends that water level capacity be used for design and engineering purposes.

CC-MAX® HEAVY DUTY

High Speed Centrifugal Discharge 210 - 900 FPM

U.S. Patent 8,240,070

THE MAXI-LIFT CC-MAX



UPGRADE TO THE ULTIMATE CC STYLE BUCKET

**TODAY'S ELEVATORS DEMAND THE
UPGRADED CC-MAX:**

**ALL THE ADVANTAGES OF THE TRADITIONAL CC STYLE
WITH THICKER WEAR POINTS**

PATENTED DESIGN:

**HIGH ROUNDED SIDES, BREAKS IN THE BOTTOM
AND A HEAVIER, THICKER FRONT LIP**

UPGRADE FROM BLUE* TO GRAY:

SET THEM SIDE BY SIDE AND DECIDE FOR YOURSELF



FEATURES & BENEFITS

- Thicker Lip - Up to 20%
- Thicker Corners - Up to 20%
- More Capacity - Up to 5%
- Clean Discharge
- High Impact & Abrasion Resistant
- Non-Corrosive, Non-Sparking
- Extends Bucket Life
- Increase & Maintain Capacity Longer
- Decreases Elevator Down Time
- Resists Hang-Ups



Reinforced Construction



Heavy Front Lip



Traditional CC Breaks



Traditional CC Style Ears

* The color blue, when used in connection with elevator buckets, is a U.S. registered trademark owned by Tapco Inc.

CC-MAX[®] HEAVY DUTY

High Speed Centrifugal Discharge 210 - 900 FPM

U.S. Patent 8,240,070



CC-MAX[®] STANDARD PROFILE

The **CC-MAX Heavy Duty** elevator bucket is a grade above older CC style buckets. It has the traditional shape, fill and discharge characteristics, with the thicker wear surfaces our buckets are famous for. The result is longer life and greater performance. **CC-MAX** buckets are direct replacements for CC and other standard bucket styles. Standard spacing is nominal projection plus 2" inches. Exceptional performance in most agricultural applications.

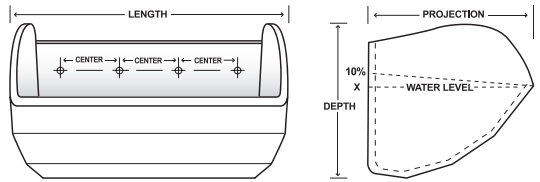

CC-MAX[®] LOW PROFILE

The **CC-MAX Low-Profile** bucket has a reduced height modification for closer vertical spacing on the belt. The low profile system allows more buckets per foot of elevator belt. When upgrading to **CC-MAX Heavy Duty Low Profile** buckets, horsepower requirements must be evaluated due to increased capacity.

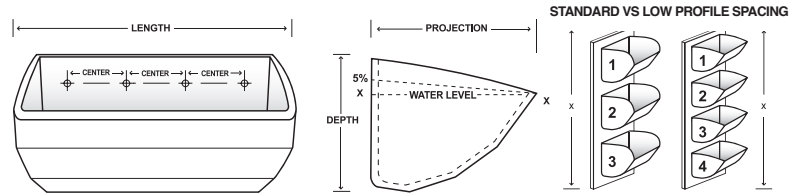

AVAILABLE MATERIALS

| | POLYETHYLENE | NYLON | URETHANE | FDA NYLON |
|------------------------------|--|--|--|--|
| Color |  Gray, White |  Tan |  Green |  White |
| Application | Grain & Food Products | Hot, high impact, abrasive dense products | Heavy abrasion, sticky materials | Hot, high impact, abrasive food grade products |
| Temperature Range | -120° F to + 180° F (210° F Intermittent) | -60° F to + 300° F (350° F Intermittent) | -60° F to + 180° F (210° F Intermittent) | -60° F to + 300° F |
| FDA Approved Material | Yes | No | Yes | Yes |
| Comments | Economical, high density polyethylene. FDA approved material for handling food grade products. | Best for high heat applications, with tough impact and abrasion needs. | Most flexible and abrasion resistant. Resists product sticking and sharp cutting particles. | Best for high heat food grade applications, with tough impact and abrasion needs. |

APPLICATIONS



FOOD
Barley, Beans, Corn, Cotton Seed, Coffee, Flour, Grains, Nuts, Rice, Sunflower, Oats, Salt, Sugar, Wheat, etc.



FEED
Bone Meal, Pellets, Meat Scrap, etc.



OTHER
Seeds, Grass Seed, Fertilizer, Perlite, Potash, Sawdust, Minerals, etc.

CC-MAX® HEAVY DUTY

Standard Profile: Polyethylene

U.S. Patent 8,240,070

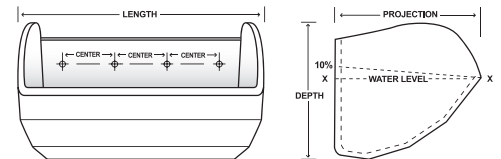

MOUNTING HOLES AND VENTING TO YOUR SPECIFICATIONS

Available Materials:



CC-MAX® Heavy Duty: Polyethylene

| BUCKET SIZE, INCHES* | | | | | PUNCHING, IN.** | | | | WEIGHT, LBS. | CAPACITY, CU. IN. | | |
|----------------------|---------|-------|-------|---------------------|-----------------|------------|-----------|----------|--------------|-------------------|-------------------|-------------|
| BUCKET SIZES | Length | Proj. | Depth | Back Wall Thickness | Centers | # of Holes | Bolt Size | Top Down | HDPE | Water Level | Water Level + 10% | Std Spacing |
| 5 x 4 | 5-1/2 | 4-1/2 | 4-1/4 | 0.21 | 3-3/16 | 2 | 1/4 | 1-7/16 | 0.53 | 38.30 | 42.13 | 6 |
| 6 x 4 | 6-1/2 | 4-1/2 | 4-1/4 | 0.21 | 4-3/8 | 2 | 1/4 | 1-7/16 | 0.58 | 45.38 | 49.92 | 6 |
| 7 x 4 | 7-1/2 | 4-1/2 | 4-1/4 | 0.21 | 2-11/16 | 3 | 1/4 | 1-7/16 | 0.65 | 52.10 | 57.31 | 6 |
| 6 x 5 | 6-1/2 | 5-1/2 | 5 | 0.26 | 4-3/8 | 2 | 1/4 | 1-11/16 | 0.89 | 70.87 | 77.96 | 7 |
| 7 x 5 | 7-1/2 | 5-1/2 | 5 | 0.26 | 2-11/16 | 3 | 1/4 | 1-11/16 | 0.99 | 80.75 | 88.83 | 7 |
| 8 x 5 | 8-1/2 | 5-1/2 | 5 | 0.26 | 3-1/16 | 3 | 1/4 | 1-11/16 | 1.10 | 90.85 | 99.94 | 7 |
| 9 x 5 | 9-1/2 | 5-1/2 | 5 | 0.26 | 3-5/8 | 3 | 1/4 | 1-11/16 | 1.18 | 100.99 | 111.09 | 7 |
| 10 x 5 | 10-1/2 | 5-1/2 | 5 | 0.26 | 4-1/8 | 3 | 1/4 | 1-11/16 | 1.31 | 114.22 | 125.64 | 7 |
| 11 x 5 | 11-1/2 | 5-1/2 | 5 | 0.26 | 3 | 4 | 1/4 | 1-11/16 | 1.45 | 127.44 | 140.18 | 7 |
| 8 x 6 | 8-9/16 | 6-5/8 | 6 | 0.27 | 3-1/16 | 3 | 1/4 | 2 | 1.40 | 136.00 | 149.6 | 8 |
| 9 x 6 | 9-9/16 | 6-5/8 | 6 | 0.27 | 3-5/8 | 3 | 1/4 | 2 | 1.52 | 149.19 | 164.11 | 8 |
| 10 x 6 | 10-9/16 | 6-5/8 | 6 | 0.27 | 4-1/8 | 3 | 1/4 | 2 | 1.64 | 166.89 | 183.58 | 8 |
| 11 x 6 | 11-9/16 | 6-5/8 | 6 | 0.27 | 3 | 4 | 1/4 | 2 | 1.73 | 180.62 | 198.68 | 8 |
| 12 x 6 | 12-9/16 | 6-5/8 | 6 | 0.27 | 3-3/8 | 4 | 1/4 | 2 | 1.91 | 200.76 | 220.83 | 8 |
| 13 x 6 | 13-9/16 | 6-5/8 | 6 | 0.27 | 3-5/8 | 4 | 1/4 | 2 | 2.13 | 215.00 | 236.50 | 8 |
| 10 x 7 | 10-9/16 | 7-7/8 | 7 | 0.32 | 4-1/8 | 3 | 5/16 | 2-3/16 | 2.35 | 236.00 | 259.60 | 9 |
| 11 x 7 | 11-9/16 | 7-7/8 | 7 | 0.32 | 3 | 4 | 5/16 | 2-3/16 | 2.44 | 247.74 | 272.52 | 9 |
| 12 x 7 | 12-9/16 | 7-7/8 | 7 | 0.32 | 3-3/8 | 4 | 5/16 | 2-3/16 | 2.63 | 267.27 | 293.99 | 9 |
| 13 x 7 | 13-9/16 | 7-7/8 | 7 | 0.32 | 3-5/8 | 4 | 5/16 | 2-3/16 | 2.78 | 284.60 | 316.93 | 9 |
| 14 x 7 | 14-9/16 | 7-7/8 | 7 | 0.32 | 3 | 5 | 5/16 | 2-3/16 | 2.94 | 303.57 | 333.93 | 9 |
| 15 x 7 | 15-9/16 | 7-7/8 | 7 | 0.35 | 3-1/4 | 5 | 5/16 | 2-3/16 | 3.10 | 335.00 | 368.50 | 9 |
| 16 x 7 | 16-9/16 | 7-7/8 | 7 | 0.35 | 2-7/8 | 6 | 5/16 | 2-3/16 | 3.29 | 350.87 | 385.95 | 9 |
| 12 x 8 | 12-9/16 | 8-7/8 | 8-1/4 | 0.35 | 3-3/8 | 4 | 5/16 | 2 | 3.25 | 373.00 | 409.00 | 10 |
| 13 x 8 | 13-9/16 | 8-7/8 | 8-1/4 | 0.35 | 3-5/8 | 4 | 5/16 | 2 | 3.51 | 404.00 | 440.00 | 10 |
| 14 x 8 | 14-9/16 | 8-7/8 | 8-1/4 | 0.35 | 3 | 5 | 5/16 | 2 | 3.76 | 435.07 | 478.58 | 10 |
| 16 x 8 | 16-9/16 | 8-7/8 | 8-1/4 | 0.38 | 2-7/8 | 6 | 5/16 | 2 | 4.30 | 515.62 | 567.18 | 10 |
| 18 x 8 | 18-9/16 | 8-7/8 | 8-1/4 | 0.39 | 3-1/8 | 6 | 5/16 | 2 | 4.79 | 580.61 | 638.67 | 10 |
| 20 x 8 | 20-9/16 | 8-7/8 | 8-1/4 | 0.42 | 3-1/2 | 6 | 5/16 | 2 | 5.85 | 655.00 | 720.00 | 10 |

*Injection molded materials shrink at differing rates. External dimensions may vary. For tight tolerances, contact Maxi-Lift for additional information.

■ - Indicates HD-MAX and CC-MAX punch patterns differ. **Reference Punching Chart on page 100.

High Speed Centrifugal Discharge 210 - 900 FPM

CC-MAX® HEAVY DUTY

Low Profile: Polyethylene, Nylon, Urethane

U.S. Patent 8,240,070

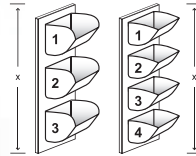

STANDARD VS LP SPACING

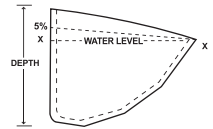
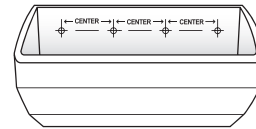

MOUNTING HOLES AND VENTING TO YOUR SPECIFICATIONS

CC-MAX® Heavy Duty Low Profile

Available Materials:



| BUCKET SIZE, INCHES* | | | | | PUNCHING, IN.** | | | | WEIGHT, LBS. | | | CAPACITY, CU. IN. | | |
|----------------------|---------|-------|-------|---------------------|-----------------|------------|-----------|----------|--------------|-------|------|-------------------|------------------|-------------|
| BUCKET SIZES | Length | Proj. | Depth | Back Wall Thickness | Centers | # of Holes | Bolt Size | Top Down | HDPE | Nylon | Uret | Water Level | Water Level + 5% | Std Spacing |
| 5 x 4 | 5-1/2 | 4-1/2 | 2-3/4 | 0.21 | 3-3/16 | 2 | 1/4 | 1 | 0.43 | 0.49 | 0.58 | 38.30 | 40.22 | 3 |
| 6 x 4 | 6-1/2 | 4-1/2 | 2-3/4 | 0.21 | 4-3/8 | 2 | 1/4 | 1 | 0.50 | 0.58 | 0.68 | 45.38 | 47.65 | 3 |
| 7 x 4 | 7-1/2 | 4-1/2 | 2-3/4 | 0.21 | 2-11/16 | 3 | 1/4 | 1 | 0.56 | 0.64 | 0.76 | 52.10 | 54.70 | 3 |
| 6 x 5 | 6-1/2 | 5-1/2 | 3-3/4 | 0.26 | 4-3/8 | 2 | 1/4 | 1 | 0.74 | 0.85 | 1 | 70.87 | 74.41 | 4 |
| 7 x 5 | 7-1/2 | 5-1/2 | 3-3/4 | 0.26 | 2-11/16 | 3 | 1/4 | 1 | 0.85 | 0.98 | 1.15 | 80.75 | 84.79 | 4 |
| 8 x 5 | 8-1/2 | 5-1/2 | 3-3/4 | 0.26 | 3-1/16 | 3 | 1/4 | 1 | 0.95 | 1.09 | 1.28 | 90.85 | 95.39 | 4 |
| 9 x 5 | 9-1/2 | 5-1/2 | 3-3/4 | 0.26 | 3-5/8 | 3 | 1/4 | 1 | 1.01 | 1.16 | 1.36 | 100.99 | 106.04 | 4 |
| 10 x 5 | 10-1/2 | 5-1/2 | 3-3/4 | 0.26 | 4-1/8 | 3 | 1/4 | 1 | 1.13 | 1.3 | 1.53 | 114.22 | 119.93 | 4 |
| 11 x 5 | 11-1/2 | 5-1/2 | 3-3/4 | 0.26 | 3 | 4 | 1/4 | 1 | 1.24 | 1.43 | 1.67 | 127.44 | 133.81 | 4 |
| 8 x 6 | 8-9/16 | 6-5/8 | 4-3/4 | 0.27 | 3-1/16 | 3 | 1/4 | 1 | 1.16 | 1.33 | 1.57 | 136.00 | 142.00 | 5 |
| 9 x 6 | 9-9/16 | 6-5/8 | 4-3/4 | 0.27 | 3-5/8 | 3 | 1/4 | 1 | 1.28 | 1.47 | 1.73 | 149.19 | 156.65 | 5 |
| 10 x 6 | 10-9/16 | 6-5/8 | 4-3/4 | 0.27 | 4-1/8 | 3 | 1/4 | 1 | 1.38 | 1.59 | 1.86 | 166.89 | 175.23 | 5 |
| 11 x 6 | 11-9/16 | 6-5/8 | 4-3/4 | 0.27 | 3 | 4 | 1/4 | 1 | 1.50 | 1.73 | 2.03 | 180.62 | 189.65 | 5 |
| 12 x 6 | 12-9/16 | 6-5/8 | 4-3/4 | 0.27 | 3-3/8 | 4 | 1/4 | 1 | 1.65 | 1.9 | 2.23 | 200.76 | 210.79 | 5 |
| 13 x 6 | 13-9/16 | 6-5/8 | 4-3/4 | 0.27 | 3-5/8 | 4 | 1/4 | 1 | 1.77 | 2.04 | 2.39 | 215.00 | 225.75 | 5 |
| 10 x 7 | 10-9/16 | 7-7/8 | 5-3/4 | 0.32 | 4-1/8 | 3 | 5/16 | 1 | 2.05 | 2.36 | 2.77 | 236.00 | 247.80 | 6 |
| 11 x 7 | 11-9/16 | 7-7/8 | 5-3/4 | 0.32 | 3 | 4 | 5/16 | 1 | 2.14 | 2.46 | 2.89 | 247.74 | 260.13 | 6 |
| 12 x 7 | 12-9/16 | 7-7/8 | 5-3/4 | 0.32 | 3-3/8 | 4 | 5/16 | 1 | 2.30 | 2.65 | 3.11 | 267.27 | 280.63 | 6 |
| 13 x 7 | 13-9/16 | 7-7/8 | 5-3/4 | 0.32 | 3-5/8 | 4 | 5/16 | 1 | 2.42 | 2.78 | 3.27 | 284.60 | 302.53 | 6 |
| 14 x 7 | 14-9/16 | 7-7/8 | 5-3/4 | 0.32 | 3 | 5 | 5/16 | 1 | 2.54 | 2.92 | 3.43 | 303.57 | 318.75 | 6 |
| 15 x 7 | 15-9/16 | 7-7/8 | 5-3/4 | 0.35 | 3-1/4 | 5 | 5/16 | 1 | 2.74 | 3.15 | 3.7 | 335.00 | 351.75 | 6 |
| 16 x 7 | 16-9/16 | 7-7/8 | 5-3/4 | 0.35 | 2-7/8 | 6 | 5/16 | 1 | 2.93 | 3.37 | 3.96 | 350.87 | 368.41 | 6 |
| 12 x 8 | 12-9/16 | 8-7/8 | 6-3/4 | 0.35 | 3-3/8 | 4 | 5/16 | 1 | 2.96 | 3.4 | 4 | 373.00 | 391.65 | 7 |
| 13 x 8 | 13-9/16 | 8-7/8 | 6-3/4 | 0.35 | 3-5/8 | 4 | 5/16 | 1 | 3.51 | 3.8 | 4.46 | 404.00 | 424.20 | 7 |
| 14 x 8 | 14-9/16 | 8-7/8 | 6-3/4 | 0.35 | 3 | 5 | 5/16 | 1 | 3.30 | 4.36 | 5.12 | 435.07 | 456.83 | 7 |
| 16 x 8 | 16-9/16 | 8-7/8 | 6-3/4 | 0.38 | 2-7/8 | 6 | 5/16 | 1 | 3.79 | 4.82 | 5.66 | 515.62 | 541.40 | 7 |
| 18 x 8 | 18-9/16 | 8-7/8 | 6-3/4 | 0.39 | 3-1/8 | 6 | 5/16 | 1 | 4.19 | 6.03 | 7.07 | 580.61 | 609.64 | 7 |
| 20 x 8 | 20-9/16 | 8-7/8 | 6-3/4 | 0.42 | 3-1/2 | 6 | 5/16 | 1 | 5.24 | 6.73 | 7.90 | 655.00 | 688.00 | 7 |

*Injection molded materials shrink at differing rates. External dimensions may vary. For tight tolerances, contact Maxi-Lift for additional information.

■ - Indicates HD-MAX and CC-MAX punch patterns differ. **Reference Punching Chart on page 100.

High Speed Centrifugal Discharge 210 - 900 FPM

CC-MAX[®] HEAVY DUTY

Standard Profile: Nylon

U.S. Patent 8,240,070

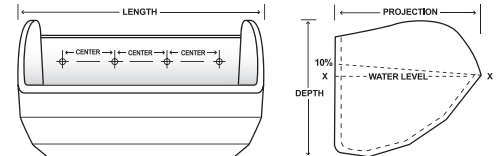

CC-MAX[®] Heavy Duty: Nylon

Available Materials:



MOUNTING HOLES AND VENTING TO YOUR SPECIFICATIONS

| BUCKET SIZE, INCHES* | | | | | PUNCHING, IN.** | | | | WEIGHT, LBS. | CAPACITY, CU. IN. | | |
|----------------------|---------|-------|-------|---------------------|-----------------|------------|-----------|----------|--------------|-------------------|-------------------|-------------|
| BUCKET SIZES | Length | Proj. | Depth | Back Wall Thickness | Centers | # of Holes | Bolt Size | Top Down | Nylon | Water Level | Water Level + 10% | Std Spacing |
| 5 x 4 | 5-1/2 | 4-1/2 | 4-1/4 | 0.21 | 3-3/16 | 2 | 1/4 | 1-7/16 | 0.61 | 38.30 | 42.13 | 6 |
| 6 x 4 | 6-1/2 | 4-1/2 | 4-1/4 | 0.21 | 4-3/8 | 2 | 1/4 | 1-7/16 | 0.70 | 45.38 | 49.92 | 6 |
| 7 x 4 | 7-1/2 | 4-1/2 | 4-1/4 | 0.21 | 2-11/16 | 3 | 1/4 | 1-7/16 | 0.80 | 52.10 | 57.31 | 6 |
| 6 x 5 | 6-1/2 | 5-1/2 | 5 | 0.26 | 4-3/8 | 2 | 1/4 | 1-11/16 | 1.02 | 70.87 | 77.96 | 7 |
| 7 x 5 | 7-1/2 | 5-1/2 | 5 | 0.26 | 2-11/16 | 3 | 1/4 | 1-11/16 | 1.15 | 80.75 | 88.83 | 7 |
| 8 x 5 | 8-1/2 | 5-1/2 | 5 | 0.26 | 3-1/16 | 3 | 1/4 | 1-11/16 | 1.25 | 90.85 | 99.94 | 7 |
| 9 x 5 | 9-1/2 | 5-1/2 | 5 | 0.26 | 3-5/8 | 3 | 1/4 | 1-11/16 | 1.35 | 100.99 | 111.09 | 7 |
| 10 x 5 | 10-1/2 | 5-1/2 | 5 | 0.26 | 4-1/8 | 3 | 1/4 | 1-11/16 | 1.51 | 114.22 | 125.64 | 7 |
| 11 x 5 | 11-1/2 | 5-1/2 | 5 | 0.26 | 3 | 4 | 1/4 | 1-11/16 | 1.67 | 127.44 | 140.18 | 7 |
| 8 x 6 | 8-9/16 | 6-5/8 | 6 | 0.27 | 3-1/16 | 3 | 1/4 | 2 | 1.61 | 136.00 | 149.6 | 8 |
| 9 x 6 | 9-9/16 | 6-5/8 | 6 | 0.27 | 3-5/8 | 3 | 1/4 | 2 | 1.75 | 149.19 | 164.11 | 8 |
| 10 x 6 | 10-9/16 | 6-5/8 | 6 | 0.27 | 4-1/8 | 3 | 1/4 | 2 | 1.89 | 166.89 | 183.58 | 8 |
| 11 x 6 | 11-9/16 | 6-5/8 | 6 | 0.27 | 3 | 4 | 1/4 | 2 | 1.95 | 180.62 | 198.68 | 8 |
| 12 x 6 | 12-9/16 | 6-5/8 | 6 | 0.27 | 3-3/8 | 4 | 1/4 | 2 | 2.20 | 200.76 | 220.83 | 8 |
| 13 x 6 | 13-9/16 | 6-5/8 | 6 | 0.27 | 3-5/8 | 4 | 1/4 | 2 | 2.45 | 215.00 | 236.50 | 8 |
| 10 x 7 | 10-9/16 | 7-7/8 | 7 | 0.32 | 4-1/8 | 3 | 5/16 | 2-3/16 | 2.70 | 236.00 | 259.60 | 9 |
| 11 x 7 | 11-9/16 | 7-7/8 | 7 | 0.32 | 3 | 4 | 5/16 | 2-3/16 | 2.81 | 247.74 | 272.52 | 9 |
| 12 x 7 | 12-9/16 | 7-7/8 | 7 | 0.32 | 3-3/8 | 4 | 5/16 | 2-3/16 | 3.02 | 267.27 | 293.99 | 9 |
| 13 x 7 | 13-9/16 | 7-7/8 | 7 | 0.32 | 3-5/8 | 4 | 5/16 | 2-3/16 | 3.20 | 284.60 | 316.93 | 9 |
| 14 x 7 | 14-9/16 | 7-7/8 | 7 | 0.32 | 3 | 5 | 5/16 | 2-3/16 | 3.40 | 303.57 | 333.93 | 9 |
| 15 x 7 | 15-9/16 | 7-7/8 | 7 | 0.35 | 3-1/4 | 5 | 5/16 | 2-3/16 | 3.57 | 335.00 | 368.50 | 9 |
| 16 x 7 | 16-9/16 | 7-7/8 | 7 | 0.35 | 2-7/8 | 6 | 5/16 | 2-3/16 | 3.78 | 350.87 | 385.95 | 9 |
| 12 x 8 | 12-9/16 | 8-7/8 | 8-1/4 | 0.35 | 3-3/8 | 4 | 5/16 | 2 | 3.74 | 373.00 | 409.00 | 10 |
| 13 x 8 | 13-9/16 | 8-7/8 | 8-1/4 | 0.35 | 3-5/8 | 4 | 5/16 | 2 | 4.03 | 404.00 | 443.79 | 10 |
| 14 x 8 | 14-9/16 | 8-7/8 | 8-1/4 | 0.35 | 3 | 5 | 5/16 | 2 | 4.32 | 435.07 | 478.58 | 10 |
| 16 x 8 | 16-9/16 | 8-7/8 | 8-1/4 | 0.38 | 2-7/8 | 6 | 5/16 | 2 | 4.85 | 515.62 | 567.18 | 10 |
| 18 x 8 | 18-9/16 | 8-7/8 | 8-1/4 | 0.39 | 3-1/8 | 6 | 5/16 | 2 | 5.30 | 580.61 | 638.67 | 10 |
| 20 x 8 | 20-9/16 | 8-7/8 | 8-1/4 | 0.42 | 3-1/2 | 6 | 5/16 | 2 | 6.73 | 655.00 | 720.00 | 10 |

*Injection molded materials shrink at differing rates. External dimensions may vary. For tight tolerances, contact Maxi-Lift for additional information. Some sizes are made to order.

■ - Indicates HD-MAX and CC-MAX punch patterns differ. **Reference Punching Chart on page 100.

OTHER CONSIDERATIONS

DRILLING: Elevator buckets are manufactured without a drill pattern. Special drilling or punching can be accommodated upon customer request.

VENTING: Available as needed. See venting options in this catalog.

DIGGER BUCKETS: Use slightly larger metal digger elevator buckets to help loosen material in the elevator boot section that has set up or hardened, thereby reducing abrasion on the plastic buckets. Call for details on Metal Digger elevator bucket options.

SPACING: See elevator bucket spacing details in the size chart (depending on materials and speeds, smaller and larger spacing may be used).

CC-MAX[®] HEAVY DUTY

Standard Profile: Urethane

U.S. Patent 8,240,070

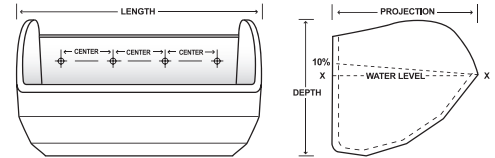

MOUNTING HOLES AND VENTING TO YOUR SPECIFICATIONS

CC-MAX[®] Heavy Duty: Urethane

| BUCKET SIZE, INCHES* | | | | | PUNCHING, IN.** | | | | WEIGHT, LBS. | CAPACITY, CU. IN. | | |
|----------------------|---------|-------|-------|---------------------|-----------------|------------|-----------|----------|--------------|-------------------|-------------------|-------------|
| BUCKET SIZES | Length | Proj. | Depth | Back Wall Thickness | Centers | # of Holes | Bolt Size | Top Down | Uret | Water Level | Water Level + 10% | Std Spacing |
| 5 x 4 | 5-1/2 | 4-1/2 | 4-1/4 | 0.21 | 3-3/16 | 2 | 1/4 | 1-7/16 | 0.72 | 38.30 | 40.22 | 6 |
| 6 x 4 | 6-1/2 | 4-1/2 | 4-1/4 | 0.21 | 4-3/8 | 2 | 1/4 | 1-7/16 | 0.80 | 45.38 | 47.65 | 6 |
| 7 x 4 | 7-1/2 | 4-1/2 | 4-1/4 | 0.21 | 2-11/16 | 3 | 1/4 | 1-7/16 | 0.88 | 52.10 | 54.70 | 6 |
| 6 x 5 | 6-1/2 | 5-1/2 | 5 | 0.26 | 4-3/8 | 2 | 1/4 | 1-11/16 | 1.20 | 70.87 | 74.41 | 7 |
| 7 x 5 | 7-1/2 | 5-1/2 | 5 | 0.26 | 2-11/16 | 3 | 1/4 | 1-11/16 | 1.40 | 80.75 | 84.79 | 7 |
| 8 x 5 | 8-1/2 | 5-1/2 | 5 | 0.26 | 3-1/16 | 3 | 1/4 | 1-11/16 | 1.50 | 90.85 | 95.39 | 7 |
| 9 x 5 | 9-1/2 | 5-1/2 | 5 | 0.26 | 3-5/8 | 3 | 1/4 | 1-11/16 | 1.65 | 100.99 | 106.04 | 7 |
| 10 x 5 | 10-1/2 | 5-1/2 | 5 | 0.26 | 4-1/8 | 3 | 1/4 | 1-11/16 | 1.77 | 114.22 | 119.93 | 7 |
| 11 x 5 | 11-1/2 | 5-1/2 | 5 | 0.26 | 3 | 4 | 1/4 | 1-11/16 | 1.96 | 127.44 | 133.81 | 7 |
| 8 x 6 | 8-9/16 | 6-5/8 | 6 | 0.27 | 3-1/16 | 3 | 1/4 | 2 | 1.95 | 136.00 | 142.00 | 8 |
| 9 x 6 | 9-9/16 | 6-5/8 | 6 | 0.27 | 3-5/8 | 3 | 1/4 | 2 | 2.10 | 149.19 | 156.65 | 8 |
| 10 x 6 | 10-9/16 | 6-5/8 | 6 | 0.27 | 4-1/8 | 3 | 1/4 | 2 | 2.25 | 166.89 | 175.23 | 8 |
| 11 x 6 | 11-9/16 | 6-5/8 | 6 | 0.27 | 3 | 4 | 1/4 | 2 | 2.40 | 180.62 | 189.65 | 8 |
| 12 x 6 | 12-9/16 | 6-5/8 | 6 | 0.27 | 3-3/8 | 4 | 1/4 | 2 | 2.55 | 200.76 | 210.79 | 8 |
| 13 x 6 | 13-9/16 | 6-5/8 | 6 | 0.27 | 3-5/8 | 4 | 1/4 | 2 | 2.88 | 215.00 | 225.75 | 8 |
| 10 x 7 | 10-9/16 | 7-7/8 | 7 | 0.32 | 4-1/8 | 3 | 5/16 | 2-3/16 | 3.17 | 236.00 | 247.80 | 9 |
| 11 x 7 | 11-9/16 | 7-7/8 | 7 | 0.32 | 3 | 4 | 5/16 | 2-3/16 | 3.29 | 247.74 | 260.13 | 9 |
| 12 x 7 | 12-9/16 | 7-7/8 | 7 | 0.32 | 3-3/8 | 4 | 5/16 | 2-3/16 | 3.55 | 267.27 | 280.63 | 9 |
| 13 x 7 | 13-9/16 | 7-7/8 | 7 | 0.32 | 3-5/8 | 4 | 5/16 | 2-3/16 | 3.75 | 284.60 | 302.53 | 9 |
| 14 x 7 | 14-9/16 | 7-7/8 | 7 | 0.32 | 3 | 5 | 5/16 | 2-3/16 | 3.97 | 303.57 | 318.75 | 9 |
| 15 x 7 | 15-9/16 | 7-7/8 | 7 | 0.35 | 3-1/4 | 5 | 5/16 | 2-3/16 | 4.19 | 335.00 | 351.75 | 9 |
| 16 x 7 | 16-9/16 | 7-7/8 | 7 | 0.35 | 2-7/8 | 6 | 5/16 | 2-3/16 | 4.44 | 350.87 | 368.41 | 9 |
| 12 x 8 | 12-9/16 | 8-7/8 | 8-1/4 | 0.35 | 3-3/8 | 4 | 5/16 | 2 | 4.39 | 373.00 | 391.65 | 10 |
| 13 x 8 | 13-9/16 | 8-7/8 | 8-1/4 | 0.35 | 3-5/8 | 4 | 5/16 | 2 | 4.73 | 404.00 | 424.24 | 10 |
| 14 x 8 | 14-9/16 | 8-7/8 | 8-1/4 | 0.35 | 3 | 5 | 5/16 | 2 | 5.08 | 435.07 | 456.83 | 10 |
| 16 x 8 | 16-9/16 | 8-7/8 | 8-1/4 | 0.38 | 2-7/8 | 6 | 5/16 | 2 | 5.81 | 515.62 | 541.40 | 10 |
| 18 x 8 | 18-9/16 | 8-7/8 | 8-1/4 | 0.39 | 3-1/8 | 6 | 5/16 | 2 | 6.47 | 580.61 | 609.64 | 10 |
| 20 x 8 | 20-9/16 | 8-7/8 | 8-1/4 | 0.42 | 3-1/2 | 6 | 5/16 | 2 | 7.90 | 655.00 | 688.00 | 10 |

* Actual dimensions may vary slightly on all elevator buckets, depending on specified raw material. Some sizes are made to order.

■ - Indicates HD-MAX and CC-MAX punch patterns differ. **Reference Punching Chart on page 100.

INSTALLATION: Use a #1 standard elevator bolt or Sabre-Tooth elevator bolt for installation. Designed to be used with fender or flat and lock washers and hex or locking nuts. If buckets are being installed on chain, use hex head bolts, nuts and washers.

ADAPTER PLATES: Recommended for chain mounting applications.

FDA: Both the urethane and polyethylene are designed to FDA specifications for direct contact with food products.

DURA-BUKET® SS SUPER STRENGTH

High Speed Centrifugal Discharge 220 - 900 FPM

THE MAXI-LIFT DURA-BUKET

THE ORIGINAL PLASTIC ELEVATOR BUCKET

THE BUCKET THAT STARTED IT ALL:
ELEVATING GRAINS, FERTILIZERS
AND FEED FOR OVER 50 YEARS.

BETTER DISCHARGE:
THE SS DISCHARGES EARLIER, GIVING MORE
TIME FOR MATERIAL TO FLOW OUT OF BUCKET.

DURABLE. IT'S IN THE NAME:
DURABLE-BUCKET: AFTER HALF A CENTURY,
NOT MUCH REMAINS TO BE SAID.



FEATURES & BENEFITS

- Lightweight
- Shape Memory
- Cleaner Discharge
- Tapered End Cap Design
- Non-Corrosive, Non-Sparking
- Resists Hang-Ups



Traditional Raised Ears



Front Lip



Center Brace



Corners

DURA-BUKET® SS

High Speed Centrifugal Discharge 220 - 900 FPM



DURA-BUKET® SS SUPER STRENGTH

The **SS** or **SUPER STRENGTH DURA-BUKET** is the original plastic elevator bucket. The **SUPER STRENGTH** elevator bucket has been running for over 50 years. It is designed at a 45-degree discharge angle and can be spaced closer on a belt giving a clean superior discharge. This bucket is lightweight and tapered for easy shipping and storage. Standard spacing is nominal projection + 1". The most common applications include grain, wheat, corn, flour, sugar and other agricultural applications. The **SS** has the most versatile design of any grain bucket and performs well in a broad range of speeds and applications.

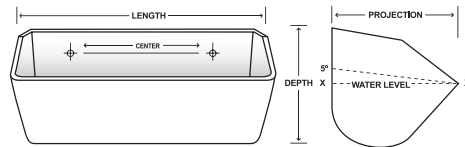



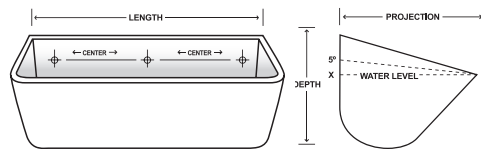

DURA-BUKET® LP LOW PROFILE

The **LP** or **LOW PROFILE DURA-BUKET** is a modification to the original plastic elevator bucket, the **SS**. It is designed at a 45-degree discharge angle and can be spaced closer on a belt giving a clean superior discharge. The most common applications include grain, wheat, corn, flour, sugar and other agricultural applications. This bucket has a reduced height modification for closer vertical spacing on the belt. The low profile system allows more buckets per foot of elevator belt. When upgrading to Low Profile buckets horsepower requirements must be evaluated due to increased capacity.



AVAILABLE MATERIALS

| | POLYETHYLENE | NYLON | URETHANE | FDA NYLON |
|------------------------------|--|--|--|--|
| Color |  White |  Tan <i>(Special Run Buckets, Not Stock Item)</i> |  Green <i>(Special Run Buckets, Not Stock Item)</i> |  White <i>(Special Run Buckets, Not Stock Item)</i> |
| Application | Grain & Food Products | Hot, high impact, abrasive dense products | Heavy abrasion, sticky materials | Hot, high impact, abrasive food grade products |
| Temperature Range | -120° F to + 180° F (210° F Intermittent) | -60° F to + 300° F (350° F Intermittent) | -60° F to + 180° F (210° F Intermittent) | -60° F to + 300° F |
| FDA Approved Material | Yes | No | Yes | Yes |
| Comments | Economical, high density polyethylene. FDA approved material for handling food grade products. | Best for high heat applications, with tough impact and abrasion needs. | Most flexible and abrasion resistant. Resists product sticking and sharp cutting particles. | Best for high heat food grade applications, with tough impact and abrasion needs. |

APPLICATIONS



FOOD
Barley, Beans, Corn, Cotton Seed, Coffee, Flour, Grains, Nuts, Rice, Sunflower, Oats, Salt, Sugar, Wheat, etc.



FEED
Bone Meal, Pellets, Meat Scrap, etc.



OTHER
Seeds, Grass Seed, Fertilizer, Perlite, Potash, Sawdust, Minerals, etc.

DURA-BUKET® SS

Standard Profile: Polyethylene

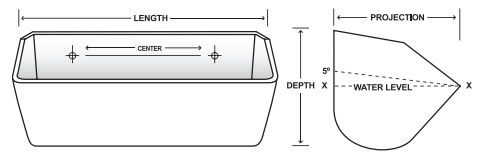

MOUNTING HOLES AND VENTING TO YOUR SPECIFICATIONS

Available Materials:

DURA-BUKET SS: Polyethylene

| BUCKET SIZE, INCHES* | | | | PUNCHING, IN.** | | | | LBS. | CAPACITY, CU. IN. | | | |
|----------------------|--------|-------|-------|-----------------|------------|-----------|----------|---------------|-------------------|-----------------------|-----------------|--|
| BUCKET SIZE | Length | Proj. | Depth | Hole Centers | # of Holes | Bolt Size | Top Down | Poly H.D.P.E. | Water Level X-X | Usable 5° over X - 5° | Minimum Spacing | |
| 4 x 3 | 4-1/4 | 3-1/8 | 3 | 2-1/4 | 2 | 1/4 | 1 | 0.17 | 10.40 | 11.00 | 4 | |
| 5 x 4 | 5-1/4 | 4-1/8 | 3-3/4 | 3-3/16 | 2 | 1/4 | 1 | 0.31 | 24.40 | 29.90 | 5 | |
| 6 x 4 | 6-1/4 | 4-1/8 | 3-3/4 | 4-3/8 | 2 | 1/4 | 1 | 0.35 | 30.80 | 33.10 | 5 | |
| 7 x 4 | 7-1/4 | 4-1/8 | 3-3/4 | 2-11/16 | 3 | 1/4 | 1 | 0.40 | 33.60 | 36.70 | 5 | |
| 6 x 5 | 6-3/8 | 5-1/4 | 4-7/8 | 4-3/8 | 2 | 1/4 | 1-1/4 | 0.59 | 47.10 | 52.00 | 6 | |
| 7 x 5 | 7-3/8 | 5-1/4 | 4-7/8 | 2-5/8 | 3 | 1/4 | 1-1/4 | 0.61 | 61.60 | 62.40 | 6 | |
| 8 x 5 | 8-3/8 | 5-1/4 | 4-7/8 | 3-1/16 | 3 | 1/4 | 1-1/4 | 0.73 | 67.70 | 69.80 | 6 | |
| 9 x 5 | 9-3/8 | 5-1/4 | 4-7/8 | 3-1/4 | 3 | 1/4 | 1-1/4 | 0.80 | 69.60 | 77.10 | 6 | |
| 8 x 6 | 8-3/8 | 6-3/8 | 6-1/4 | 3-1/16 | 3 | 1/4 | 1-1/4 | 1.02 | 104.40 | 107.70 | 7 | |
| 9 x 6 | 9-3/8 | 6-5/8 | 6-1/4 | 3-1/2 | 3 | 1/4 | 1-1/4 | 1.12 | 124.50 | 132.20 | 7 | |
| 10 x 6 | 10-3/8 | 6-3/8 | 6-1/4 | 4 | 3 | 1/4 | 1-3/4 | 1.14 | 128.20 | 145.80 | 7 | |
| 11 x 6 | 11-3/8 | 6-3/8 | 6-1/4 | 3 | 4 | 1/4 | 1-3/4 | 1.26 | 147.70 | 157.90 | 7 | |
| * 12 x 6 | 12-3/8 | 6-3/4 | 6-1/2 | 3-3/8 | 4 | 1/4 | 1-3/4 | 1.70 | 172.10 | 183.60 | 7 | |
| * 13 x 6 | 13-3/8 | 6-3/4 | 6-1/2 | 3-5/8 | 4 | 1/4 | 1-3/4 | 1.95 | 196.50 | 208.70 | 7 | |
| 10 x 7 | 10-3/8 | 7-3/8 | 7-1/4 | 4 | 3 | 5/16 | 1-3/4 | 1.54 | 175.80 | 187.30 | 8 | |
| 11 x 7 | 11-3/8 | 7-3/8 | 7-1/4 | 3 | 4 | 5/16 | 1-3/4 | 1.65 | 210.50 | 216.70 | 8 | |
| * 12 x 7 | 12-3/8 | 7-3/8 | 7-1/4 | 3-3/8 | 4 | 5/16 | 1-3/4 | 2.02 | 223.20 | 241.10 | 8 | |
| * 13 X 7 | 13-3/8 | 7-3/8 | 7-1/4 | 3-5/8 | 4 | 5/16 | 1-3/4 | 2.17 | 236.80 | 244.80 | 8 | |
| * 14 X 7 | 14-3/8 | 7-3/8 | 7-1/4 | 3 | 5 | 5/16 | 1-1/2 | 2.29 | 269.70 | 290.10 | 8 | |
| * 15 x 7 | 15-3/8 | 7-3/8 | 7-1/4 | 3-1/4 | 5 | 5/16 | 1-1/2 | 2.35 | 284.40 | 295.00 | 8 | |
| * 16 x 7 | 16-3/8 | 7-3/8 | 7-1/4 | 3-1/2 | 5 | 5/16 | 1-1/2 | 2.55 | 289.90 | 304.80 | 8 | |
| * 12 x 8 | 12-3/8 | 8-3/8 | 8-1/4 | 3-3/8 | 4 | 5/16 | 1-3/4 | 2.33 | 272.50 | 299.90 | 9 | |
| * 14 x 8 | 14-3/8 | 8-3/8 | 8-1/4 | 3 | 5 | 5/16 | 1-1/2 | 2.58 | 324.70 | 364.80 | 9 | |
| * 16 x 8 | 16-3/8 | 8-3/8 | 8-1/4 | 3-1/2 | 5 | 5/16 | 2 | 3.33 | 362.50 | 407.60 | 9 | |
| * 18 x 8 | 18-3/8 | 8-3/8 | 8-1/4 | 3-1/8 | 6 | 5/16 | 2 | 3.75 | 404.90 | 440.60 | 9 | |

*Injection molded materials shrink at differing rates. External dimensions may vary. For tight tolerances, contact Maxi-Lift for additional information.

■ - Indicates SS and LP punch patterns differ. *Buckets with 12" lengths and up have a center brace. **Reference Punching Chart on page 100.

High Speed Centrifugal Discharge 220 - 900 FPM

DURA-BUKET® LP

Low Profile: Polyethylene

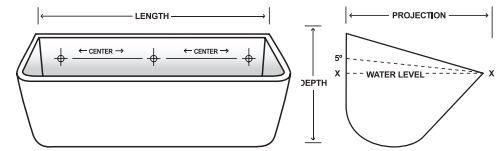

MOUNTING HOLES AND VENTING TO YOUR SPECIFICATIONS

DURA-BUKET LP: LOW PROFILE

Available Materials:

| BUCKET SIZE, INCHES* | | | | PUNCHING, IN.** | | | | WEIGHT, LBS. | CAPACITY, CU. IN. | | | |
|----------------------|--------|-------|-------|-----------------|------------|-----------|----------|---------------|-------------------|-----------------------|-----------------|--|
| BUCKET SIZE | Length | Proj. | Depth | Hole Centers | # of Holes | Bolt Size | Top Down | Poly H.D.P.E. | Water Level X-X | Usable 5° over X - 5° | Minimum Spacing | |
| 4 x 3 | 4 | 3-1/8 | 3 | 2-1/4 | 2 | 1/4 | 1 | 0.15 | 10.4 | 11.0 | 3 | |
| 5 x 4 | 5-1/8 | 4-1/8 | 3 | 3-3/16 | 2 | 1/4 | 1 | 0.25 | 24.4 | 29.9 | 3-1/4 | |
| 6 x 4 | 6-1/8 | 4-1/8 | 3 | 4-1/4 | 2 | 1/4 | 1 | 0.29 | 30.8 | 33.1 | 3-1/4 | |
| 7 x 4 | 7-1/8 | 4-1/8 | 3 | 2-5/8 | 3 | 1/4 | 1 | 0.34 | 33.6 | 36.7 | 3-1/4 | |
| 6 x 5 | 6-1/8 | 5-1/4 | 3-3/4 | 4-1/4 | 2 | 1/4 | 1 | 0.47 | 47.1 | 52.0 | 3-3/4 | |
| 7 x 5 | 7-1/8 | 5-1/4 | 3-3/4 | 2-5/8 | 3 | 1/4 | 1 | 0.51 | 61.6 | 62.4 | 3-3/4 | |
| 8 x 5 | 8-1/8 | 5-1/4 | 3-3/4 | 3-1/16 | 3 | 1/4 | 1 | 0.52 | 67.7 | 69.8 | 3-3/4 | |
| 9 x 5 | 9-1/8 | 5-1/4 | 3-3/4 | 3-1/4 | 3 | 1/4 | 1 | 0.64 | 69.6 | 77.1 | 3-3/4 | |
| 8 x 6 | 8-1/8 | 6-3/8 | 4-1/2 | 2-11/16 | 3 | 5/16 | 1 | 0.80 | 104.4 | 107.7 | 4-3/8 | |
| 9 x 6 | 9-1/8 | 6-5/8 | 4-1/2 | 3-1/2 | 3 | 5/16 | 1 | 0.93 | 124.5 | 132.2 | 4-3/8 | |
| 10 x 6 | 10-1/8 | | 4-1/2 | 4 | 3 | 5/16 | 1 | 0.87 | 128.2 | 145.8 | 4-3/8 | |
| 11 x 6 | 11-1/8 | 6-3/8 | 4-1/2 | 2-7/8 | 4 | 5/16 | 1 | 0.98 | 147.7 | 157.9 | 4-3/8 | |
| * 12 x 6 | 12-1/8 | 6-3/4 | 5 | 3-1/4 | 4 | 5/16 | 1 | 1.43 | 172.1 | 183.6 | 5 | |
| * 13 x 6 | 13-1/8 | 6-3/4 | 5 | 3-5/8 | 4 | 5/16 | 1 | 1.61 | 196.5 | 208.7 | 5 | |
| 10 x 7 | 10-1/8 | 7-3/8 | 5-1/4 | 4 | 3 | 5/16 | 1 | 1.25 | 175.8 | 187.3 | 5 | |
| 11 x 7 | 11-1/8 | 7-3/8 | 5-1/4 | 3 | 4 | 5/16 | 1 | 1.25 | 210.5 | 216.7 | 5 | |
| * 12 x 7 | 12-1/8 | 7-3/8 | 5-1/4 | 3-1/4 | 4 | 5/16 | 1 | 1.64 | 223.2 | 241.1 | 5 | |
| * 13 X 7 | 13-1/8 | 7-3/8 | 5-1/4 | 3-5/8 | 4 | 5/16 | 1 | 1.71 | 236.8 | 244.8 | 5 | |
| * 14 X 7 | 14-3/8 | 7-3/8 | 5-1/4 | 4 | 4 | 5/16 | 1 | 1.83 | 269.7 | 290.1 | 5 | |
| * 15 x 7 | 15-1/8 | 7-3/8 | 5-1/4 | 2-5/8 | 6 | 5/16 | 1 | 1.97 | 284.4 | 295.0 | 5 | |
| * 16 x 7 | 16-1/8 | 7-3/8 | 5-1/4 | 2-5/8 | 6 | 5/16 | 1 | 2.06 | 289.9 | 304.8 | 5 | |
| * 12 x 8 | 12-1/8 | 8-3/8 | 5-3/4 | 3-1/4 | 4 | 5/16 | 1-1/4 | 1.87 | 272.5 | 299.9 | 5-1/2 | |
| * 14 x 8 | 14-1/8 | 8-3/8 | 5-3/4 | 4 | 4 | 5/16 | 1-1/4 | 2.05 | 324.7 | 364.8 | 5-1/2 | |
| * 16 x 8 | 16-1/8 | 8-3/8 | 5-3/4 | 2-5/8 | 6 | 5/16 | 1-1/4 | 2.72 | 362.5 | 407.6 | 5-1/2 | |
| * 18 x 8 | 18-1/4 | 8-3/8 | 5-3/4 | 3-1/8 | 6 | 5/16 | 1-1/4 | 3.00 | 404.9 | 440.6 | 5-1/2 | |

*Injection molded materials shrink at differing rates. External dimensions may vary. For tight tolerances, contact Maxi-Lift for additional information.

■ - Indicates SS and LP punch patterns differ. *Buckets with 12" lengths and up have a center brace. **Reference Punching Chart on page 100.

High Speed Centrifugal Discharge 220 - 900 FPM

DURA-BUKET® PEANUT BUCKET

No Ears - Style P: Polyethylene

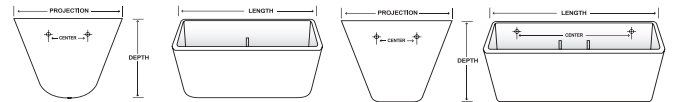

Available Materials:

NO EARS - STYLE P: PEANUT BUCKET

| BUCKET SIZE, INCHES | | | | PUNCHING, INCHES | | | | | WEIGHT, LBS. | CAPACITY, CU. IN. |
|---------------------|---------|-------|--------|------------------|------------|-----------|----------|--------------------|--------------|-------------------|
| BUCKET SIZE | Length | Proj. | Depth | Hole Centers | # of Holes | Bolt Size | Top Down | Top Side to Center | H.D.P.E. | Water Level X-X |
| 6 x 4 | 6-1/4 | 4-1/8 | 3 | 2 | 2 (Ends) | 1/4 | 1 | 1 | 0.33 | 47.47 |
| 7 x 5 | 7-3/8 | 5-1/4 | 4 | 2 | 2 (Ends) | 1/4 | 7/8 | 7/8 | 0.60 | 91.53 |
| 9 x 5 | 9-3/8 | 5-1/4 | 4 | 2 | 2 (Ends) | 1/4 | 1 | 1 | 0.79 | 117.77 |
| 9 x 6 | 9-3/8 | 6-5/8 | 5-1/2 | 2 | 2 (Ends) | 1/4 | 1 | 1 | 1.09 | 192.82 |
| 12 x 6 | 12-3/8 | 6-3/4 | 5-1/2 | 2 | 2 (Ends) | 1/4 | 1 | 1 | 1.63 | 257.08 |
| 18 x 6 | 17-3/4 | 7-3/4 | 5-1/2 | 2 | 2 (Ends) | 1/4 | 1 | 1 | 2.85 | 408.83 |
| 24 x 6 | 24-3/16 | 7-3/4 | 5-1/2 | 2 | 2 (Ends) | 1/4 | 1 | 1 | 3.23 | 610.23 |
| 11 x 7 | 11-3/8 | 7-3/8 | 6 | 2 | 2 (Ends) | 1/4 | 1 | 1 | 1.56 | 314.25 |
| 14 x 7 | 14-3/8 | 7-3/8 | 6-1/4 | 2 | 2 (Ends) | 1/4 | 1 | 1 | 2.23 | 414.94 |
| 16 x 7 | 16-3/8 | 7-3/8 | 6 | 2 | 2 (Ends) | 1/4 | 1 | 1 | 2.53 | 434.46 |
| 12 x 8 | 12-3/8 | 8-3/8 | 7 | 2 | 2 (Ends) | 1/4 | 1 | 1 | 2.26 | 408.83 |
| 18 x 8 | 18-1/8 | 8-7/8 | 7-1/16 | 2 | 2 (Ends) | 1/4 | 1 | 1 | 3.25 | 404.90 |
| 24 x 10 | 24 | 9-1/8 | 7-5/8 | 2-1/2 | 2 (Ends) | 3/8 | 3-1/4 | 1 | 5.86 | 1067.85 |

*Injection molded materials shrink at differing rates. External dimensions may vary. For tight tolerances, contact Maxi-Lift for additional information.

OTHER CONSIDERATIONS

ENGINEERING: Please see Section 5 of catalog for detailed engineering, speed and capacity information.

DRILLING: Elevator Buckets are manufactured without a drill pattern. Special drilling or punching can be accommodated upon customer request.

*Mounting Holes drilled 1/32 to 1/16 over bolt diameter for easier application.

VENTING: Available as needed. See venting options in this catalog.

CC STEEL, STEEL DIGGER BUCKETS

Fabricated Steel Buckets



CC-STEEL ELEVATOR BUCKET

(See Chart on Pg 44)

STANDARD DUTY CC-STEEL

The **CC STEEL** Elevator Buckets is made of mild steel for mounting on belt or chain. Traditional agriculture style bucket can also be transformed into a heavier gauge steel for lighter weight industrial duty applications. Elevator buckets can be made from 18GA to 1/4" thick carbon steel and stainless steel. Buckets are vented as #3 standard. Buckets are spot welded.

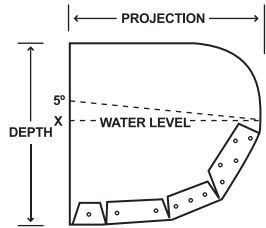

FEATURES & BENEFITS

- Traditional CC Shape
- High Speed
- High Capacity
- High Wear Resistance



STEEL DIGGER ELEVATOR BUCKETS

(CC-DIGGER SHOWN)

(See Chart on Pg 45)

**CUSTOM SIZES OF STEEL DIGGER
ELEVATOR BUCKETS
AVAILABLE UPON REQUEST**

STEEL DIGGER BUCKETS

Maxi-Lift **DIGGER** buckets aid in breaking up material in the boot section of a bucket elevator. Diggers extend 1/4" further than plastic elevator buckets. Weights and dimensions will vary. Tolerance is a 1/4" on all bucket dimensions except bolt hole diameter which is 1/16". Capacity is based off of plastic elevator buckets of similar style. Buckets available in carbon or stainless steel. Additional AR wear lips, back plates and venting available upon request. Buckets available in other gauges including 14GA, 12GA, 10GA, 7GA, 1/4" thick.

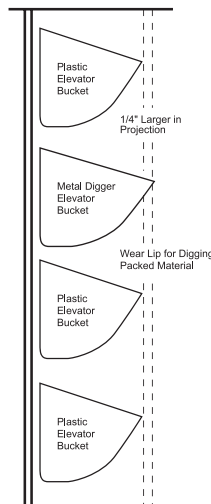

FEATURES & BENEFITS

- Thicker Walls, Heavy Front Lip for Digging
- Increase Plastic Bucket Life
- Breaks Packed Materials
- Easy to Install

STANDARD DUTY CC STEEL

Other Sizes Available Upon Request

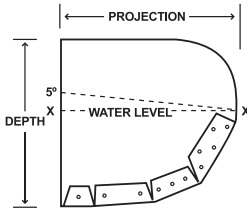

CC-STEEL ELEVATOR BUCKET

STANDARD DUTY CC METAL

| BUCKET SIZE, INCHES | | | PUNCHING, INCHES | | | WEIGHT, LBS. | | CAPACITY, CU. IN. | | |
|---------------------|---------|---------|------------------|------------|-----------|----------------|-----------------------|------------------------|-----------------|-------------------|
| BUCKET SIZE | P Proj. | D Depth | Centers | # of Holes | Bolt Size | Standard Gauge | Approx. Weight - LBS. | Gross Capacity Cu. In. | Minimum Spacing | Number Per Carton |
| 4 x 3 | 3-3/16 | 2-11/16 | 2-1/2 | 2 | 1/4 | 16 | .62 | 22 | 5 | 84 |
| 4 x 4 | 4-3/16 | 4 | 2-1/2 | 2 | 1/4 | 18 | .90 | 39 | 6 | 84 |
| 5 x 4 | 4-3/16 | 4 | 3-3/16 | 2 | 1/4 | 18 | .95 | 52 | 6 | 84 |
| 6 x 4 | 4-3/16 | 4 | 4-3/8 | 2 | 1/4 | 18 | 1.10 | 62 | 6 | 84 |
| 7 x 4 | 4-3/16 | 4 | 2-11/16 | 3 | 1/4 | 18 | 1.25 | 70 | 6 | 84 |
| 8 x 4 | 4-3/16 | 4 | 3-1/16 | 3 | 1/4 | 18 | 1.50 | 79 | 6 | 84 |
| 9 x 4 | 4-3/16 | 4 | 3-5/8 | 3 | 1/4 | 18 | 1.70 | 90 | 6 | 56 |
| 6 x 5 | 5-1/4 | 5 | 4-3/8 | 2 | 1/4 | 16 | 1.60 | 94 | 7 | 54 |
| 7 x 5 | 5-1/4 | 5 | 2-11/16 | 3 | 1/4 | 16 | 1.75 | 110 | 7 | 54 |
| 8 x 5 | 5-1/4 | 5 | 3-1/16 | 3 | 1/4 | 16 | 2.00 | 125 | 7 | 54 |
| 9 x 5 | 5-1/4 | 5 | 3-5/8 | 3 | 1/4 | 16 | 2.50 | 140 | 7 | 36 |
| 10 x 5 | 5-1/4 | 5 | 4-1/8 | 3 | 1/4 | 16 | 2.70 | 155 | 7 | 36 |
| 11 x 5 | 5-1/4 | 5 | 3 | 4 | 1/4 | 16 | 2.90 | 170 | 7 | 36 |
| 12 x 5 | 5-1/4 | 5 | 3-3/8 | 4 | 1/4 | 16 | 3.00 | 185 | 7 | 36 |
| 7 x 6 | 6-5/16 | 6 | 2-11/16 | 3 | 1/4 | 16 | 2.85 | 155 | 8 | 36 |
| 8 x 6 | 6-5/16 | 6 | 3-1/16 | 3 | 1/4 | 16 | 3.10 | 178 | 8 | 36 |
| 9 x 6 | 6-5/16 | 6 | 3-5/8 | 3 | 1/4 | 16 | 3.40 | 202 | 8 | 24 |
| 10 x 6 | 6-5/16 | 6 | 4-1/8 | 3 | 1/4 | 16 | 3.50 | 222 | 8 | 24 |
| 11 x 6 | 6-5/16 | 6 | 3 | 4 | 1/4 | 16 | 3.75 | 244 | 8 | 24 |
| 12 x 6 | 6-5/16 | 6 | 3-3/8 | 4 | 1/4 | 16 | 4.00 | 267 | 8 | 24 |
| 13 x 6 | 6-5/16 | 6 | 3-5/8 | 4 | 1/4 | 16 | 4.50 | 289 | 8 | 24 |
| 14 x 6 | 6-5/16 | 6 | 3 | 5 | 1/4 | 16 | 4.75 | 312 | 8 | 24 |
| 8 x 7 | 7-3/16 | 7 | 3-1/16 | 3 | 5/16 | 14 | 4.60 | 242 | 9 | 24 |
| 9 x 7 | 7-3/16 | 7 | 3-5/8 | 3 | 5/16 | 14 | 4.80 | 276 | 9 | 24 |
| 10 x 7 | 7-3/16 | 7 | 4-1/8 | 3 | 5/16 | 14 | 5.00 | 302 | 9 | 16 |
| 11 x 7 | 7-3/16 | 7 | 3 | 4 | 5/16 | 14 | 5.25 | 333 | 9 | 16 |
| 12 x 7 | 7-3/16 | 7 | 3-3/8 | 4 | 5/16 | 14 | 6.25 | 362 | 9 | 16 |
| 13 x 7 | 7-3/16 | 7 | 3-5/8 | 4 | 5/16 | 14 | 6.75 | 393 | 9 | 16 |
| 14 x 7 | 7-3/16 | 7 | 3 | 5 | 5/16 | 14 | 7.00 | 424 | 9 | 16 |
| 15 x 7 | 7-3/16 | 7 | 3-1/4 | 5 | 5/16 | 14 | 7.50 | 454 | 9 | 8 |
| 16 x 7* | 7-3/16 | 7 | 2-7/8 | 6 | 5/16 | 14 | 8.00 | 486 | 9 | 8 |
| 18 x 7* | 7-3/16 | 7 | 3-1/8 | 6 | 5/16 | 14 | 8.50 | 544 | 9 | 8 |
| 20 x 7* | 7-3/16 | 7 | 3-1/2 | 6 | 5/16 | 14 | 9.25 | 605 | 9 | 8 |
| 22 x 7* | 7-3/16 | 7 | 4 | 6 | 5/16 | 14 | 10.00 | 664 | 9 | 8 |
| 24 x 7* | 7-3/16 | 7 | 3-1/2 | 7 | 5/16 | 14 | 10.75 | 725 | 9 | 8 |
| 9 x 8 | 8-1/8 | 8 | 3-5/8 | 3 | 5/16 | 14 | 5.60 | 349 | 10 | 16 |
| 10 x 8 | 8-1/8 | 8 | 4-1/8 | 3 | 5/16 | 14 | 6.10 | 388 | 10 | 16 |
| 11 x 8 | 8-1/8 | 8 | 3 | 4 | 5/16 | 14 | 6.75 | 427 | 10 | 16 |
| 12 x 8 | 8-1/8 | 8 | 3-3/8 | 4 | 5/16 | 14 | 7.50 | 466 | 10 | 16 |
| 13 x 8 | 8-1/8 | 8 | 3-5/8 | 4 | 5/16 | 14 | 7.75 | 505 | 10 | 16 |
| 14 x 8 | 8-1/8 | 8 | 3 | 5 | 5/16 | 14 | 8.25 | 543 | 10 | 16 |
| 15 x 8 | 8-1/8 | 8 | 3-1/4 | 5 | 5/16 | 14 | 8.50 | 582 | 10 | 8 |
| 16 x 8* | 8-1/8 | 8 | 2-7/8 | 6 | 5/16 | 14 | 9.00 | 621 | 10 | 8 |
| 17 x 8* | 8-1/8 | 8 | 3 | 6 | 5/16 | 14 | 9.50 | 660 | 10 | 8 |
| 18 x 8* | 8-1/8 | 8 | 3-1/8 | 6 | 5/16 | 14 | 9.75 | 698 | 10 | 8 |
| 20 x 8* | 8-1/8 | 8 | 3-1/2 | 6 | 5/16 | 14 | 10.75 | 776 | 10 | 8 |
| 22 x 8* | 8-1/8 | 8 | 4 | 6 | 5/16 | 14 | 11.50 | 854 | 10 | 8 |
| 24 x 8* | 8-1/8 | 8 | 3-1/2 | 7 | 5/16 | 14 | 12.00 | 931 | 10 | 8 |

* Supplied with lip brace. Lip brace is optional on other sizes at slightly higher cost. ** Other sizes available on request *** indicates buckets are stocked vented and non-vented. #3 Vent pattern does not include holes on ends of elevator bucket. Usable capacity is based on 75% gross capacity.

STEEL DIGGER BUCKETS

HD-MAX®, CC-MAX® & TIGER-TUFF®

HD-MAX® STEEL DIGGERS

| BUCKET SIZE, INCHES | | | |
|---------------------|--------|--------|-------|
| BUCKET SIZE | Length | Proj. | Depth |
| 3 x 2 | 3-3/4 | 2-9/16 | 2-1/4 |
| 4 x 3 | 4-7/8 | 3-1/2 | 3 |
| 5 x 4 | 5-3/4 | 4-3/4 | 4 |
| 6 x 4 | 6-3/4 | 4-3/4 | 4 |
| 7 x 4 | 7-3/4 | 4-3/4 | 4 |
| 6 x 5 | 6-7/8 | 5-7/8 | 5 |
| 7 x 5 | 7-7/8 | 5-7/8 | 5 |
| 8 x 5 | 8-7/8 | 5-7/8 | 5 |
| 9 x 5 | 9-7/8 | 5-7/8 | 5 |
| 10 x 5 | 10-3/4 | 5-7/8 | 5 |
| 11 x 5 | 11-3/4 | 5-7/8 | 5 |
| 12 x 5 | 12-3/4 | 5-7/8 | 5 |
| 8 x 6 | 8-7/8 | 6-7/8 | 6 |
| 9 x 6 | 9-7/8 | 6-7/8 | 6 |
| 10 x 6 | 10-7/8 | 7-1/8 | 6 |
| 11 x 6 | 11-7/8 | 7-1/8 | 6 |
| 12 x 6 | 12-7/8 | 7-1/8 | 6 |
| 13 x 6 | 13-7/8 | 7-1/8 | 6 |
| 10 x 7 | 10-3/4 | 8 | 7-1/8 |
| 11 x 7 | 11-3/4 | 8 | 7-1/8 |
| 12 x 7 | 12-3/4 | 8 | 7-1/8 |
| 13 x 7 | 13-3/4 | 8 | 7-1/8 |
| 14 x 7 | 14-3/4 | 8 | 7-1/8 |
| 15 x 7 | 15-3/4 | 8 | 7-1/8 |
| 16 x 7 | 16-3/4 | 8 | 7-1/8 |
| 10 x 8 | 10-3/4 | 9 | 8 |
| 11 x 8 | 11-3/4 | 9 | 8 |
| 12 x 8 | 12-3/4 | 9 | 8 |
| 13 x 8 | 13-3/4 | 9 | 8 |
| 14 x 8 | 14-3/4 | 9 | 8 |
| 15 x 8 | 15-3/4 | 9 | 8 |
| 16 x 8 | 16-3/4 | 9 | 8 |
| 18 x 8 | 18-3/4 | 9 | 8 |

CC-MAX® STEEL DIGGERS

| BUCKET SIZE, INCHES | | | |
|---------------------|----------|-------|-------|
| BUCKET SIZE | Length | Proj. | Depth |
| 5 x 4 | 6 | 4-3/4 | 4-1/4 |
| 6 x 4 | 7 | 4-3/4 | 4-1/4 |
| 7 x 4 | 8 | 4-3/4 | 4-1/4 |
| 6 x 5 | 7 | 5-3/4 | 5 |
| 7 x 5 | 8 | 5-3/4 | 5 |
| 8 x 5 | 9 | 5-3/4 | 5 |
| 9 x 5 | 10 | 5-3/4 | 5 |
| 10 x 5 | 11 | 5-3/4 | 5 |
| 11 x 5 | 11-13/16 | 5-3/4 | 5 |
| 8 x 6 | 8-13/16 | 7-1/8 | 6 |
| 9 x 6 | 9-13/16 | 7-1/8 | 6 |
| 10 x 6 | 10-13/16 | 7-1/8 | 6 |
| 11 x 6 | 11-13/16 | 7-1/8 | 6 |
| 12 x 6 | 12-13/16 | 7-1/8 | 6 |
| 13 x 6 | 13-13/16 | 7-1/8 | 6 |
| 10 x 7 | 10-13/16 | 8-1/8 | 7 |
| 11 x 7 | 11-13/16 | 8-1/8 | 7 |
| 12 x 7 | 12-13/16 | 8-1/8 | 7 |
| 13 x 7 | 13-13/16 | 8-1/8 | 7 |
| 14 x 7 | 14-13/16 | 8-1/8 | 7 |
| 15 x 7 | 15-13/16 | 8-1/8 | 7 |
| 16 x 7 | 16-13/16 | 8-1/8 | 7 |
| 12 x 8 | 12-13/16 | 9-1/8 | 8-1/4 |
| 13 x 8 | 13-13/16 | 9-1/8 | 8-1/4 |
| 14 x 8 | 14-13/16 | 9-1/8 | 8-1/4 |
| 16 x 8 | 16-13/16 | 9-1/8 | 8-1/4 |
| 18 x 8 | 18-13/16 | 9-1/8 | 8-1/4 |
| 20 x 8 | 20-13/16 | 9-1/8 | 8-1/4 |

TIGER-TUFF® STEEL DIGGERS (Additional Sizes Available, Call for Details)

| BUCKET SIZE, INCHES | | | | PUNCHING, IN. | | | LBS. | CAP., CU. IN. | |
|---------------------|--------|--------|-------|---------------|------------|-----------|--------------------|-----------------|---------------------|
| BUCKET SIZE | Length | Proj. | Depth | Hole Centers | # of Holes | Bolt Size | 10 GA Carbon Steel | Water Level X-X | Usable 5° over X-5° |
| 12 x 7 | 13-3/8 | 8-1/8 | 7 | 3-3/8 | 4 | 5/16 | 15.70 | 283.18 | 312.06 |
| 13 x 7 | 14-3/8 | 8-1/8 | 7 | 3-5/8 | 4 | 5/16 | 16.35 | 292.51 | 323.22 |
| 14 x 7 | 15-3/8 | 8-1/8 | 7 | 3 | 5 | 5/16 | 17.00 | 331.49 | 365.30 |
| 15 x 7 | 16-3/8 | 8-1/8 | 7 | 3-1/4 | 5 | 5/16 | 17.65 | 346.64 | 383.38 |
| 16 x 7 | 17-3/8 | 8-1/8 | 7 | 2-7/8 | 6 | 5/16 | 18.30 | 379.90 | 418.65 |
| 11 x 8 | 12-3/8 | 8-1/8 | 8-1/4 | 3 | 4 | 5/16 | 17.33 | 340.02 | 374.70 |
| 12 x 8 | 13-3/8 | 9-1/8 | 8-1/4 | 3-3/8 | 4 | 5/16 | 18.90 | 373.00 | 411.08 |
| 13 x 8 | 13-7/8 | 9-1/8 | 8-1/4 | 3-5/8 | 4 | 5/16 | 19.90 | 404.85 | 446.15 |
| 14 x 8 | 15-7/8 | 9-1/8 | 8-1/4 | 3 | 5 | 5/16 | 21.30 | 436.80 | 481.35 |
| 16 x 8 | 17-1/2 | 9-3/4 | 8-1/8 | 2-7/8 | 6 | 5/16 | 23.10 | 512.57 | 566.39 |
| 18 x 8 | 19-1/2 | 9-3/4 | 8-1/4 | 3-1/8 | 6 | 5/16 | 25.20 | 567.49 | 627.08 |
| 20 x 8 | 21-1/2 | 9-3/4 | 8-1/4 | 3-1/2 | 6 | 5/16 | 27.00 | 646.81 | 714.73 |
| 22 x 8 | 23-1/2 | 9-3/4 | 8-1/4 | 4 | 6 | 5/16 | 29.43 | 701.90 | 757.40 |
| 24 x 8 | 25-1/2 | 9-3/4 | 8-1/4 | 3-1/2 | 7 | 5/16 | 31.37 | 763.40 | 831.08 |
| 16 x 10 | 17-1/2 | 11-3/4 | 10 | 2-7/8 | 6 | 5/16 | 30.00 | 795.70 | 875.37 |
| 18 x 10 | 19-1/4 | 11-1/2 | 10 | 3-1/8 | 6 | 5/16 | 32.50 | 910.00 | 1001.21 |
| 20 x 10 | 21-1/2 | 11-1/2 | 10 | 3-1/2 | 6 | 5/16 | 35.60 | 1032.5 | 1135.98 |

THREE FOR FREE ORDER FORM

Complete and Fax Back to: 972-735-8896

To begin seeing the unique advantages of our tougher, thicker, and longer lasting maximum duty elevator buckets, please complete the following information and fax this page to 972-735-8896. We will send you 3 FREE BUCKETS.

USER INFORMATION (Primary Bucket Contact)

Name _____ Title _____

Company Name _____

Shipping Address _____

City _____ State _____ Zip _____

Phone _____ Fax _____

Current Bucket Supplier _____

1. Average Bucket Life _____

2. Current Bucket Brand Name _____

3. Size & Style Now in Use _____

4. Current Bucket Problem _____

5. Material Being Elevated _____

6. Current Belt Spacing _____

7. Hole Punch Spacing _____

8. Belt Width _____

* We are unable to pay for shipping expenses on samples shipping outside the U.S.
Free samples limited to injection molded designs

SELECT BUCKET STYLE:

 **TIGER-TUFF**
MAXIMUM DUTY ELEVATOR BUCKET



 **TIGER-CC**
MAXIMUM DUTY ELEVATOR BUCKET



 **HD-MAX**
HEAVY DUTY ELEVATOR BUCKET



 **CC-MAX**
HEAVY DUTY ELEVATOR BUCKET



 **MAXI-TUFF AA**
ELEVATOR BUCKET
MAXIMUM DUTY INDUSTRIAL BUCKET



 **MAXI-TUFF ME**
ELEVATOR BUCKET
MAXIMUM DUTY INDUSTRIAL BUCKET



 **TIGER-TUFF**
INDUSTRIAL ELEVATOR BUCKETS.
MAXIMUM DUTY INDUSTRIAL BUCKET



 **TIGER-CC**
INDUSTRIAL ELEVATOR BUCKETS.
MAXIMUM DUTY INDUSTRIAL ELEVATOR BUCKET



AGRICULTURAL
INDUSTRIAL

MAXI-LIFT



INDUSTRIAL ELEVATOR BUCKETS

UPGRADE TO THE TOUGHEST
ELEVATOR BUCKETS

- **MAXI-TUFF AA & MF**
MAXIMUM DUTY
- **TIGER-TUFF**
INDUSTRIAL
- **TIGER-CC**
INDUSTRIAL
- **DI-MAX AA & AC**
DUCTILE IRON
- **DIGGER BUCKETS**
WELDED STEEL
- **WELDED
STEEL**

MAXI-LIFT



MAXI-TUFF® AA MAXIMUM DUTY

Slow Speed Centrifugal Discharge 125-450 FPM

THE MAXI-LIFT MAXI-TUFF AA

MAXI-TUFF® AA
ELEVATOR BUCKET

UPGRADE TO THE TOUGHEST INDUSTRIAL BUCKET

**THE #1 SELLING PLASTIC INDUSTRIAL
BUCKET IN NORTH AMERICA!**
THE BEST BUCKET FOR TOUGH, ABRASIVE
INDUSTRIAL APPLICATIONS.

**DESIGNED AND ENGINEERED FOR THE
TOUGHEST INDUSTRIAL MATERIALS**
SAND, CEMENT, GLASS, AGGREGATE & MORE.



FEATURES & BENEFITS

- Reduces Weight on Elevator up to 80%
- Up to 25% More Capacity than Cast Iron Buckets
- Thicker Walls, Heavy Front Digging Lip
- Heat, Impact and Abrasion Resistant
- Non-Corrosive, Non-Sparking
- Easier to Install and Replace
- Cleaner Discharge than Steel Buckets
- Reduces Energy Usage
- Extends Bucket Life
- Lowers Elevator Maintenance
- Decreases Elevator Down-Time
- Saves Money Versus Carbon Steel



Reinforced Corners



Heavy Front Lip



Front Ribs



Thick Back Wall

MAXI-TUFF® AA MAXIMUM DUTY

Slow Speed Centrifugal Discharge 125-450 FPM



LAFARGE CEMENT TERMINAL REDUCES WEAR & NOISE WITH MAXI-TUFF®

When heavy cast iron buckets were in use at the Lafarge cement distribution terminal in Carrollton, Michigan, wear on steel chain and the head and tail sprockets resulted in excessive maintenance and replacement costs. According to Gene Meyers, manager of the Lafarge terminal, chains had to be replaced at 5-year intervals. "After more than two years of operation with **MAXI-TUFF** buckets, we see almost no chain or sprocket wear and the drive components are holding up much better than they did with iron buckets," said Meyers. Quieter operation is another bonus with the **MAXI-TUFF** buckets. "This gives us a real improvement in working conditions," Meyers said. Lafarge's 80 ft. elevator uses a total of 180 **MAXI-TUFF** buckets to convey upwards of 600 tons of cement daily. The nylon buckets tip the scales at only 4.25 lbs. each, versus 23 lbs. for the old cast iron buckets. The total weight of the **MAXI-TUFF** buckets is only 765 lbs., compared with 4,140 lbs. for the cast iron, a weight savings of more than 3,300 lbs.! Built to handle the toughest applications, the **MAXI-TUFF** paves the way for more efficient operation at Lafarge.



SILICA SAND PLANT REDUCES DOWNTIME, CUTS COST WITH MAXI-TUFF®

Osburn Materials operates ten hours a day, six days a week cleaning and processing silica sand for use in foundries, oil field applications and water filtration facilities. Annually, they process over 300,000 tons of silica sand. Initially, Osburn Materials used heavy chain and steel buckets to convey their sand. It only took one chain failure for Bob Tooke to look for a more efficient solution. "When all that steel came crashing down, there was just too much damage," said Tooke, President of Osburn Materials. They decided to switch to the **MAXI-TUFF** nylon elevator buckets and after 4 years of service, an inspection of the buckets revealed almost no wear. "Not only is there no wear, but we have never had a **MAXI-TUFF** crack or break," said Clay Tooke. Osburn fitted their expansion elevators with **MAXI-TUFF** nylon AA style buckets. "We never considered any other buckets for the new legs," said Tooke. For their tough silica sand operation, Osburn Materials will rely on the **MAXI-TUFF**.



'HOT SHOT' ABRASIVES PLANT RACKS UP SAVINGS WITH MAXI-TUFF®

At National Metal Abrasives Inc., Wadsworth, Ohio, **MAXI-TUFF** elevator buckets are racking up cost savings as they transport 300 tons of steel shot daily. The fully automated plant runs 24 hours a day, seven days a week. Its two 102-foot tall bucket elevators remove freshly-formed shot from quenching pits and deliver it to dryers. In the past, cast iron buckets used on the elevator wore out every six months. Also, the uneven wear of the cast iron buckets caused frequent shutdowns for replacements. "We're getting three times as much life out of each (**MAXI-TUFF**) bucket. **MAXI-TUFF** buckets are tougher, lighter and they cost about the same as cast iron," says Maintenance Manager, Clyde Robison. Now, more than 2-1/2 years later, the **MAXI-TUFF** buckets are actually outwearing the belts themselves. "We have to replace the belts every 18 months; but when we do replace the belts, the buckets are still in serviceable condition," reports National Metal's Executive VP, Bob Fuller. In the most severe of applications, the **MAXI-TUFF** once again proves why it is considered the standard in industrial elevator buckets.

MAXI-TUFF® AA MAXIMUM DUTY

Slow Speed Centrifugal Discharge 125-450 FPM



MAXI-TUFF® AA ELEVATOR BUCKET

AVAILABLE MATERIALS

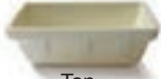
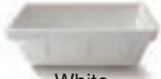
| | NYLON | URETHANE | POLYETHYLENE | FDA NYLON |
|------------------------------|--|--|--|--|
| Color |  Tan |  Green |  White |  White |
| Application | Hot, high impact, abrasive, dense products | Heavy abrasion, sticky materials | Food Products | Hot, high impact, abrasive, dense products |
| Temperature Range | -60° F to + 300° F (350° F Intermittent) | -60° F to + 180° F (210° F Intermittent) | -120° F to + 180° F (210° F Intermittent) | -60° F to + 300° F |
| FDA Approved Material | No | Yes | Yes | Yes |
| Comments | Best for high heat applications, with tough impact and abrasion needs. | Most flexible and abrasion resistant. Resists product sticking and sharp cutting particles. | Economical, high density polyethylene. FDA approved material for handling food grade products. | Best for high heat applications, with tough impact and abrasion needs. |

APPLICATIONS



AGGREGATES

Asphalt, Clays, Coal, Limestone, Minerals, Ores, Silica Sand, Steel Shot, Wood Chips, etc.



POWDERS

Alumina, Bauxite, Cement, Chemicals, Fly Ash, Gypsum, Lime, Phosphates, Sawdust, etc.



AND MORE

Salt, Sugar, Cullet, Pellets, Fertilizer, Fullers Earth, etc.

MAXI-TUFF® AA MAXIMUM DUTY

Slow Speed Centrifugal Discharge 125-450 FPM



MAXI-TUFF AA
ELEVATOR BUCKET

MORE CAPACITY: MORE CAPACITY

| CAPACITY | Cast Nylons | Rexnord | Cast Iron | MAXI-TUFF |
|----------|-------------|---------|-----------|-----------|
| 100% | | | | |
| 90% | | | | |
| 80% | | | | |
| 70% | | | | |
| 60% | | | | |

Call Maxi-Lift for specific size comparison. Data taken from published literature for each brand.

WEIGHT COMPARISON: LESS WEIGHT

| WEIGHT, LBS. | Cast Iron | 10 Gauge | MAXI-TUFF |
|--------------|-----------|----------|-----------|
| 200 | | | |
| 150 | | | |
| 100 | | | |
| 50 | | | |
| 0 | | | |

Lower value means lower weight.

IZOD IMPACT TEST: IMPACT RESISTANCE

| PRESSURE (LBS / SQ.IN.) | BEFORE Heat Aging | | AFTER Heat Aging (150°C 100 hrs) | |
|-------------------------|----------------------------------|---|----------------------------------|---|
| | 2.5 | Average 2.3975 Lbs./Sq.In. Resistance | | Average 2.3975 Lbs./Sq.In. Resistance |
| 2.0 | | | | |
| 1.5 | | | | |
| 1.0 | | | | |
| 0.5 | 0.99 Lbs./Sq.In. to Failure | | | |
| 0.0 | 0.443 Lbs./Sq.In. to Fracture | | 0.45 Lbs./Sq.In. to Failure | |
| | MAXI-TUFF | Cast Nylon | MAXI-TUFF | Cast Nylon |

MAXI-TUFF® AA MAXIMUM DUTY

The **MAXI-TUFF AA** centrifugal elevator bucket has the traditional shape of a cast iron bucket. This bucket has a heavy reinforced lip and corners with a thickened back wall for mounting strength. Standard spacing is projection x 2. The most common applications include handling stone, sand, gravel, coal, fertilizer, clay, salt, limestone and cement. **MAXI-TUFF AA** bucket is the best bucket for tough, abrasive industrial applications.

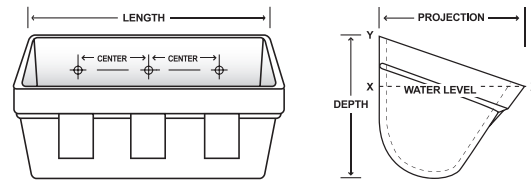

INCREASE YOUR CARRYING CAPACITY

MAXI-TUFF's deeper profile and straighter sides give more carrying capacity than competing brands and cast iron buckets. Maximize your elevated capacity by installing like size **MAXI-TUFF's**. **MAXI-TUFF** elevator buckets average more capacity than other AA buckets.

LOWER THE WEIGHT IN YOUR ELEVATOR

MAXI-TUFF's non-metallic material reduces weight on your drives and other elevating components. It reduces wear and tear on the most costly elevator parts and reduces energy consumption; that saves money. **MAXI-TUFF** also reduces operating noise - a great secondary benefit. **MAXI-TUFF** weighs on average:

- 78.2% LESS THAN CAST IRON**
- 69.3% LESS THAN 10 GAUGE STEEL**

MORE IMPACT RESISTANT

Maxi-Lift uses high pressure injection molding to manufacture the **MAXI-TUFF** bucket. The high pressure eliminates pockets and bubbles in the material. The result is a uniformly solid part. Other companies use a casting process to mold their buckets. Methods used to make the material pourable for castings leave bubbles and pockets in the finished part. The result is a bucket with a much lower impact resistance. Lab testing shows a significant difference in impact strength, tensile strength and elongation to break. Cast nylon also becomes brittle in heat testing, while our injection molded Nylon stays tough. **MAXI-TUFF's** superior impact strength means longer life in your rugged industrial application!

MAXI-TUFF® AA MAXIMUM DUTY

Nylon



MAXI-TUFF® AA ELEVATOR BUCKET

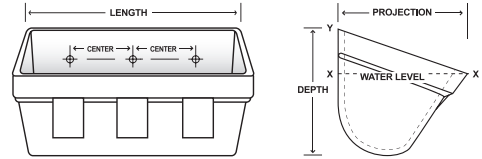

MOUNTING HOLES AND VENTING TO YOUR SPECIFICATIONS

Available Materials:



MAXI-TUFF® AA: NYLON

| BUCKET SIZE, INCHES* | | | | | WEIGHT, LBS. | CAPACITY | | |
|----------------------|--------|--------|--------|---------------------|--------------|-------------------------|-----------------------|-------------|
| BUCKET SIZE | Length | Proj. | Depth | Back Wall Thickness | Nylon | Water Level Cu. In. X-X | Capacity Cu. Feet X-X | Std Spacing |
| 4 x 3 | 4-1/4 | 3-1/8 | 3-1/8 | 0.205 | 0.20 | 13.40 | 0.008 | 6 |
| 5 x 4 | 5-1/4 | 4-1/8 | 4-1/8 | 0.205 | 0.51 | 34.80 | 0.020 | 8 |
| 6 x 4 | 6-1/4 | 4-1/8 | 4-1/8 | 0.205 | 0.56 | 41.50 | 0.024 | 8 |
| 7 x 4 | 7-1/4 | 4-1/8 | 4-1/8 | 0.225 | 0.65 | 51.30 | 0.030 | 8 |
| 7 x 5 | 7-1/8 | 5-1/8 | 5-1/4 | 0.325 | 0.93 | 76.60 | 0.044 | 10 |
| 8 x 5 | 8-1/8 | 5-1/8 | 5-1/4 | 0.325 | 1.17 | 89.70 | 0.052 | 10 |
| 9 x 5 | 9-1/8 | 5-1/8 | 5-1/4 | 0.320 | 1.17 | 101.30 | 0.059 | 10 |
| 9 x 6 | 9-3/8 | 6-1/8 | 6-1/8 | 0.290 | 1.45 | 132.40 | 0.077 | 12 |
| 10 x 6 | 10-3/8 | 6-1/8 | 6-1/8 | 0.322 | 1.54 | 148.30 | 0.086 | 12 |
| 11 x 6 | 11-3/8 | 6-1/8 | 6-1/8 | 0.285 | 1.63 | 163.50 | 0.095 | 12 |
| 12 x 6 | 12-3/8 | 6-1/8 | 6-1/8 | 0.345 | 2.21 | 186.10 | 0.108 | 12 |
| 12 x 7 | 12-3/8 | 7-1/8 | 7-1/8 | 0.284 | 2.47 | 244.10 | 0.141 | 14 |
| 14 x 7 | 14-3/8 | 7-1/8 | 7-1/8 | 0.300 | 2.91 | 298.40 | 0.173 | 14 |
| 14 x 8 | 14-3/8 | 8-1/8 | 8-1/8 | 0.455 | 4.12 | 351.50 | 0.204 | 16 |
| 16 x 8 | 16-3/8 | 8-1/8 | 8-1/8 | 0.455 | 4.62 | 406.40 | 0.235 | 16 |
| 18 x 8 | 18-1/8 | 8-1/8 | 8-1/8 | 0.455 | 5.24 | 467.40 | 0.271 | 16 |
| 18 x 10 | 18-1/2 | 10-1/8 | 10-1/8 | 0.463 | 7.80 | 692.60 | 0.401 | 20 |

*Injection molded materials shrink at differing rates. External dimensions may vary. For tight tolerances, contact Maxi-Lift for additional information.

OTHER CONSIDERATIONS

- ENGINEERING:** Please see Section 5 of the catalog for detailed engineering, speed and capacity information.
- DRILLING:** Elevator Buckets are manufactured without a drill pattern. Special drilling or punching can be accommodated upon customer request.
- *Mounting Holes drilled 1/32 to 1/16 over bolt diameter for easier installation.
- VENTING:** Available as needed. Call for recommendations.
- DIGGER BUCKETS:** Use slightly larger metal digger buckets to help loosen material in the elevator boot section that has set up or hardened, thereby reducing abrasion on the plastic buckets. Call for details on Metal Digger elevator bucket options.
- INSTALLATION:** Use a #1 standard elevator bolt or Sabre-Tooth elevator bolt for installation. Designed to be used with fender or flat and lock washers and hex or locking nuts. If buckets are being installed on a chain, use hex head bolts, nuts and washers. A locking device should always be used.
- ADAPTER PLATES:** Recommended for chain mounting applications.
- FDA:** Both the urethane and polyethylene are designed to FDA specifications for direct contact with food products. Special food grade nylon is also available for high heat applications.
- SPACING:** PROJECTION x 2 = STANDARD VERTICAL SPACING (depending on materials and speeds, closer or wider spacing may be used).

MAXI-TUFF® AA MAXIMUM DUTY

Urethane



MAXI-TUFF® AA ELEVATOR BUCKET

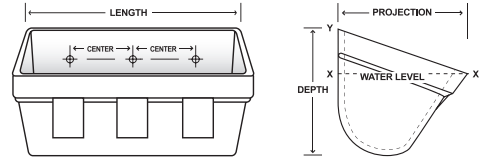

MOUNTING HOLES AND VENTING TO YOUR SPECIFICATIONS

Available Materials:

MAXI-TUFF® AA: URETHANE

| BUCKET SIZE, INCHES | | | | | WEIGHT, LBS. | CAPACITY | | |
|---------------------|--------|--------|--------|---------------------|--------------|-------------------------|-----------------------|-------------|
| BUCKET SIZE | Length | Proj. | Depth | Back Wall Thickness | Urethane | Water Level Cu. In. X-X | Capacity Cu. Feet X-X | Std Spacing |
| 4 x 3 | 4-1/4 | 3-1/8 | 3-1/8 | 0.205 | 0.24 | 13.40 | 0.008 | 6 |
| 5 x 4 | 5-1/4 | 4-1/8 | 4-1/8 | 0.205 | 0.60 | 34.80 | 0.020 | 8 |
| 6 x 4 | 6-1/4 | 4-1/8 | 4-1/8 | 0.205 | 0.69 | 41.50 | 0.024 | 8 |
| 7 x 4 | 7-1/4 | 4-1/8 | 4-1/8 | 0.225 | 0.78 | 51.30 | 0.030 | 8 |
| 7 x 5 | 7-1/8 | 5-1/8 | 5-1/4 | 0.325 | 1.14 | 76.60 | 0.044 | 10 |
| 8 x 5 | 8-1/8 | 5-1/8 | 5-1/4 | 0.325 | 1.40 | 89.70 | 0.052 | 10 |
| 9 x 5 | 9-1/8 | 5-1/8 | 5-1/4 | 0.320 | 1.41 | 101.30 | 0.059 | 10 |
| 9 x 6 | 9-3/8 | 6-1/8 | 6-1/8 | 0.290 | 1.72 | 132.40 | 0.077 | 12 |
| 10 x 6 | 10-3/8 | 6-1/8 | 6-1/8 | 0.322 | 1.88 | 148.30 | 0.086 | 12 |
| 11 x 6 | 11-3/8 | 6-1/8 | 6-1/8 | 0.285 | 1.99 | 163.50 | 0.095 | 12 |
| 12 x 6 | 12-3/8 | 6-1/8 | 6-1/8 | 0.345 | 2.62 | 186.10 | 0.108 | 12 |
| 12 x 7 | 12-3/8 | 7-1/8 | 7-1/8 | 0.284 | 3.00 | 244.10 | 0.141 | 14 |
| 14 x 7 | 14-3/8 | 7-1/8 | 7-1/8 | 0.300 | 3.50 | 298.40 | 0.173 | 14 |
| 14 x 8 | 14-3/8 | 8-1/8 | 8-1/8 | 0.455 | 4.93 | 351.50 | 0.204 | 16 |
| 16 x 8 | 16-3/8 | 8-1/8 | 8-1/8 | 0.455 | 5.58 | 406.40 | 0.235 | 16 |
| 18 x 8 | 18-1/8 | 8-1/8 | 8-1/8 | 0.455 | 6.09 | 467.40 | 0.271 | 16 |
| 18 x 10 | 18-1/2 | 10-1/8 | 10-1/8 | 0.463 | 9.40 | 692.60 | 0.401 | 20 |

*Injection molded materials shrink at differing rates. External dimensions may vary. For tight tolerances, contact Maxi-Lift for additional information.

Slow Speed Centrifugal Discharge 125-450 FPM

MAXI-TUFF® AA MAXIMUM DUTY

Polyethylene



MAXI-TUFF® AA ELEVATOR BUCKET

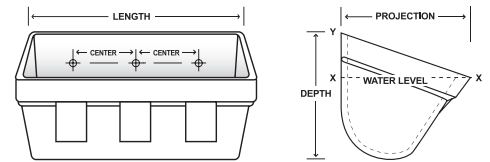

MOUNTING HOLES AND VENTING TO YOUR SPECIFICATIONS

Available Materials:



MAXI-TUFF® AA: POLYETHYLENE

| BUCKET SIZE, INCHES* | | | | | WEIGHT, LBS. | CAPACITY | | |
|----------------------|--------|--------|--------|---------------------|--------------|-------------------------|-----------------------|-------------|
| BUCKET SIZE | Length | Proj. | Depth | Back Wall Thickness | HDPE | Water Level Cu. In. X-X | Capacity Cu. Feet X-X | Std Spacing |
| 4 x 3 | 4-1/4 | 3-1/8 | 3-1/8 | 0.205 | 0.18 | 13.40 | 0.008 | 6 |
| 5 x 4 | 5-1/4 | 4-1/8 | 4-1/8 | 0.205 | 0.44 | 34.80 | 0.020 | 8 |
| 6 x 4 | 6-1/4 | 4-1/8 | 4-1/8 | 0.205 | 0.49 | 41.50 | 0.024 | 8 |
| 7 x 4 | 7-1/4 | 4-1/8 | 4-1/8 | 0.225 | 0.56 | 51.30 | 0.030 | 8 |
| 7 x 5 | 7-1/8 | 5-1/8 | 5-1/4 | 0.325 | 0.82 | 76.60 | 0.044 | 10 |
| 8 x 5 | 8-1/8 | 5-1/8 | 5-1/4 | 0.325 | 1.02 | 89.70 | 0.052 | 10 |
| 9 x 5 | 9-1/8 | 5-1/8 | 5-1/4 | 0.320 | 1.02 | 101.30 | 0.059 | 10 |
| 9 x 6 | 9-3/8 | 6-1/8 | 6-1/8 | 0.290 | 1.23 | 132.40 | 0.077 | 12 |
| 10 x 6 | 10-3/8 | 6-1/8 | 6-1/8 | 0.322 | 1.39 | 148.30 | 0.086 | 12 |
| 11 x 6 | 11-3/8 | 6-1/8 | 6-1/8 | 0.285 | 1.43 | 163.50 | 0.095 | 12 |
| 12 x 6 | 12-3/8 | 6-1/8 | 6-1/8 | 0.345 | 1.95 | 186.10 | 0.108 | 12 |
| 12 x 7 | 12-3/8 | 7-1/8 | 7-1/8 | 0.284 | 2.21 | 244.10 | 0.141 | 14 |
| 14 x 7 | 14-3/8 | 7-1/8 | 7-1/8 | 0.300 | 2.57 | 298.40 | 0.173 | 14 |
| 14 x 8 | 14-3/8 | 8-1/8 | 8-1/8 | 0.455 | 3.64 | 351.50 | 0.204 | 16 |
| 16 x 8 | 16-3/8 | 8-1/8 | 8-1/8 | 0.455 | 4.12 | 406.40 | 0.235 | 16 |
| 18 x 8 | 18-1/8 | 8-1/8 | 8-1/8 | 0.455 | 4.52 | 467.40 | 0.271 | 16 |
| 18 x 10 | 18-1/2 | 10-1/8 | 10-1/8 | 0.463 | 6.83 | 692.60 | 0.401 | 20 |

*Injection molded materials shrink at differing rates. External dimensions may vary. For tight tolerances, contact Maxi-Lift for additional information.

Slow Speed Centrifugal Discharge 125-450 FPM

MAXI-TUFF® MF (MEDIUM FRONT)

Slow Speed Continuous Discharge 1-250 FPM

THE MAXI-LIFT MAXI-TUFF MF

MAXI-TUFF® MF
ELEVATOR BUCKET

UPGRADE TO THE TOUGHEST INDUSTRIAL BUCKET

**THE #1 SELLING PLASTIC INDUSTRIAL
BUCKET IN NORTH AMERICA!**
THE BEST BUCKET FOR TOUGH,
ABRASIVE INDUSTRIAL APPLICATIONS.

**DESIGNED AND ENGINEERED FOR THE
TOUGHEST INDUSTRIAL MATERIALS**
SAND, CEMENT, GLASS, AGGREGATE, ETC.



FEATURES & BENEFITS

- Reduces Weight on Elevator up to 80%
- Thicker Walls, Heavy Front Digging Lip
- Heat, Impact and Abrasion Resistant
- Non-Corrosive, Non-Sparking
- Cleaner Discharge than Steel Buckets
- Reduces Energy Usage
- Extends Bucket Life
- Lowers Elevator Maintenance
- Decreases Elevator Down-Time
- Saves Money Versus Carbon Steel



Reinforced Corners



Heavy Front Lip



Thick Side Walls



Thick Back Wall



MAXI-TUFF® MF MAXIMUM DUTY

Slow Speed Continuous Discharge 1-250 FPM

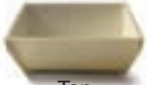

MAXI-TUFF® MF ELEVATOR BUCKET

AVAILABLE MATERIALS

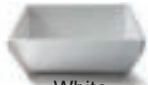
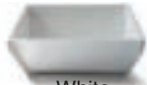
| | NYLON | URETHANE | POLYETHYLENE | FDA NYLON |
|------------------------------|--|--|--|--|
| Color |  Tan |  Green |  White |  White |
| Application | Hot, high impact, abrasive, dense products | Heavy abrasion, sticky materials | Food Products | Hot, high impact, abrasive, dense products |
| Temperature Range | -60° F to + 300° F (350° F Intermittent) | -60° F to + 180° F (210° F Intermittent) | -120° F to + 180° F (210° F Intermittent) | -60° F to + 300° F |
| FDA Approved Material | No | Yes | Yes | Yes |
| Comments | Best for high heat applications, with tough impact and abrasion needs. | Most flexible and abrasion resistant. Resists product sticking and sharp cutting particles. | Economical, high density polyethylene. FDA approved material for handling food grade products. | Best for high heat food grade applications, with tough impact and abrasion needs. |

APPLICATIONS



AGGREGATES

Asphalt, Clays, Coal, Limestone, Minerals, Ores, Silica Sand, Steel Shot, Wood Chips, etc.



POWDERS

Alumina, Bauxite, Cement, Chemicals, Fly Ash, Gypsum, Lime, Phosphates, Sawdust, etc.



AND MORE

Salt, Sugar, Cullet, Pellets, Fertilizer, Fullers Earth, etc.

MAXI-TUFF® MF (MEDIUM FRONT)

Nylon, Urethane, Polyethylene



MAXI-TUFF MF
ELEVATOR BUCKET

MAXI-TUFF® MF MAXIMUM DUTY

The **MAXI-TUFF MF** Medium Front continuous elevator bucket has the traditional shape of an MF steel elevator bucket. It also has a heavy reinforced lip and corners with a thickened back wall for mounting strength. Standard vertical spacing is depth + 1/4". The most common applications include fertilizer, clay, alumina and pellets. The **MAXI-TUFF MF** is the best bucket for fluffy or free flowing materials or those which require gentle handling.

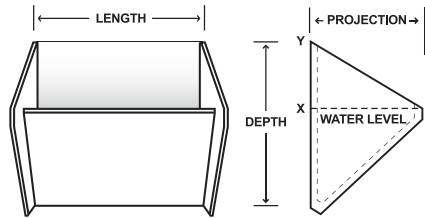

MOUNTING HOLES AND VENTING TO YOUR SPECIFICATIONS

MAXI-TUFF® MF: CONTINUOUS DISCHARGE

Available Materials:



| BUCKET SIZE, INCHES* | | | | | WEIGHT, LBS. | | | CAPACITY | | |
|----------------------|--------|-------|--------|---------------------|--------------|----------|------|-------------------------|-----------------------|-------------|
| BUCKET SIZE | Length | Proj. | Depth | Back Wall Thickness | Nylon | Urethane | HDPE | Water Level Cu. In. X-X | Capacity Cu. Feet X-X | Std Spacing |
| 8 x 5 x 7 | 8-1/4 | 5-1/2 | 7-1/2 | 0.380 | 1.97 | 2.37 | 1.70 | 80.56 | 0.047 | 8 |
| 10 x 5 x 7 | 10-1/4 | 5-1/2 | 7-1/2 | 0.395 | 2.32 | 2.86 | 2.04 | 94.90 | 0.055 | 8 |
| 12 x 7 x 11 | 12-1/4 | 7-1/2 | 11-1/2 | 0.350 | 4.00 | 4.80 | 3.62 | 172.63 | 0.100 | 12 |
| 14 x 7 x 11 | 14-1/4 | 7-1/2 | 11-1/2 | 0.325 | 4.53 | 5.33 | 3.88 | 201.30 | 0.117 | 12 |
| 16 x 7 x 11 | 16-1/4 | 7-1/2 | 11-1/2 | 0.325 | 4.97 | 5.97 | 4.39 | 238.81 | 0.138 | 12 |
| 18 x 7 x 11 | 18-1/4 | 7-1/2 | 11-1/2 | 0.325 | 5.83 | 6.74 | 4.95 | 244.31 | 0.141 | 12 |
| 12 x 8 x 11 | 12-1/4 | 8-1/2 | 11-1/2 | 0.325 | 4.81 | 5.65 | 4.32 | 274.60 | 0.159 | 12 |
| 14 x 8 x 11 | 14-1/4 | 8-1/2 | 11-1/2 | 0.325 | 5.26 | 6.28 | 4.57 | 335.61 | 0.194 | 12 |
| 16 x 8 x 11 | 16-1/4 | 8-1/2 | 11-1/2 | 0.325 | 5.81 | 7.03 | 5.17 | 396.63 | 0.230 | 12 |
| 18 x 8 x 11 | 18-1/4 | 8-1/2 | 11-1/2 | 0.325 | 6.77 | 7.94 | 5.83 | 467.65 | 0.271 | 12 |

*Injection molded materials shrink at differing rates. External dimensions may vary. For tight tolerances, contact Maxi-Lift for additional information.

OTHER CONSIDERATIONS

ENGINEERING: Please see Section 5 of catalog for detailed engineering, speed and capacity information.

DRILLING: Elevator Buckets are manufactured without a drill pattern. Special drilling or punching can be accommodated upon customer request.

*Mounting Holes drilled 1/32 to 1/16 over bolt diameter for easier installation.

VENTING: Available as needed. Call for recommendations.

DIGGER BUCKETS: Use slightly larger metal digger buckets to help loosen material in the elevator boot section that has set up or hardened, thereby reducing abrasion on the plastic buckets. Call for details on Metal Digger elevator bucket options.

SPACING: Depth + 1/4" = most practical vertical spacing (depending on materials and speeds, smaller and larger spacing may be used).

INSTALLATION: Use a #1 standard elevator bolt or Sabre-Tooth elevator bolt for installation. Designed to be used with fender or flat washers and hex or locking nuts. If buckets are being installed on a chain, use hex head bolts, nuts and washers. A locking device should always be used.

ADAPTER PLATES: Recommended for chain mounting applications.

FDA: Both the urethane and polyethylene are designed to FDA specifications for direct contact with food products.

Special food grade nylon is also available for high heat applications.

Slow Speed Continuous Discharge 1-250 FPM

TIGER-TUFF® INDUSTRIAL

Slow Speed Centrifugal Discharge 125-450 FPM

THE MAXI-LIFT TIGER-TUFF



TIGER-TUFF
INDUSTRIAL ELEVATOR BUCKETS®

THE INDUSTRIAL STRENGTH TIGER-TUFF

THICKER. TOUGHER. LASTS LONGER:
DESIGNED FOR THE TOUGHEST
APPLICATIONS - FOR THOSE WHO
DON'T HAVE TIME TO BE DOWN

ENGINEERED FOR ULTIMATE RELIABILITY:
THE THICKEST FRONT LIP AND CORNERS
GIVE THE LONGEST BUCKET LIFE



FEATURES & BENEFITS

- More Capacity Than Typical AA Buckets
- Thicker Than Most AA Plastic Buckets
- Reduces Weight on Elevator up to 80%
- More Capacity than Cast Iron Buckets
- Thicker Walls, Heavy Front Digging Lip
- Heat, Impact and Abrasion Resistant
- Non-Corrosive, Non-Sparking
- Easier to Install and Replace
- Cleaner Discharge
- Reduces Build-Up in Bottom of Buckets
- Reduces Energy Usage
- Extends Bucket Life
- Lowers Elevator Maintenance
- Decreases Elevator Down-Time
- Saves Money Versus Carbon Steel



Thick Back Wall



Heavy Duty Construction



Heavy Front Lip



Reinforced Corners

TIGER-TUFF® INDUSTRIAL

Slow Speed Centrifugal Discharge 125-450 FPM





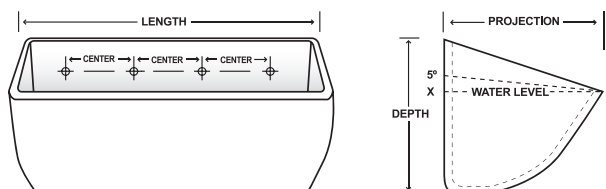

TIGER-TUFF® INDUSTRIAL

The **TIGER-TUFF** Industrial is a maximum duty industrial elevator bucket, designed and engineered to maximize bucket life and elevated capacity. This will reduce down time and lower maintenance costs. The **TIGER-TUFF** Industrial bucket has the thickest lip, back wall and corners to maximize bucket life and maintain capacity. Standard spacing is projection x 2. The most common applications include aggregate, sand, gravel, coal, gypsum, limestone, clay, cement and many, many more. The **TIGER-TUFF** Industrial is the maximum duty industrial bucket for your most demanding industrial applications.



AVAILABLE MATERIALS

| | NYLON | POLYETHYLENE | URETHANE | FDA NYLON |
|------------------------------|---|--|---|---|
| Color |  Tan |  Orange |  Green |  White |
| Application | Hot, high impact, abrasive, dense products | Food Products | Heavy abrasion, sticky materials | Hot, high impact, abrasive food grade products |
| Temperature Range | -60° F to + 300° F (350° F Intermittent) | -120° F to + 180° F (210° F Intermittent) | -60° F to + 180° F (210° F Intermittent) | -60° F to + 300° F |
| FDA Approved Material | No | Yes | Yes | Yes |
| Comments | Best for high heat applications, with tough impact and abrasion needs. | Economical, high density polyethylene. FDA approved material for handling food grade products. | Most flexible and abrasion resistant. Resists product sticking and sharp cutting particles. | Best for high heat applications, with tough impact and abrasion needs. |

APPLICATIONS



AGGREGATES
Asphalt, Clays, Coal, Limestone, Minerals, Ores, Silica Sand, Steel Shot, Wood Chips, etc.



POWDERS
Alumina, Bauxite, Cement, Chemicals, Fly Ash, Gypsum, Lime, Phosphates, Sawdust, etc.



AND MORE
Salt, Sugar, Cullet, Pellets, Fertilizer, Fullers Earth, etc.

OTHER CONSIDERATIONS

ENGINEERING: Please see Section 5 of catalog for detailed engineering, speed and capacity information.

DRILLING: Elevator Buckets are manufactured without a drill pattern. Special drilling or punching can be accommodated upon customer request.

*Mounting Holes drilled 1/32 to 1/16 over bolt diameter for easier installation.

VENTING: Available as needed. See venting options in this catalog.

DIGGER BUCKETS: Use slightly larger metal digger elevator buckets to help loosen material in the elevator boot section that has set up or hardened, thereby reducing abrasion on the plastic buckets. Call for details on Metal Digger elevator bucket options.

INSTALLATION: Use a #1 standard elevator bolt or Sabre-Tooth elevator bolt for installation. Designed to be used with fender or flat and lock washers and hex or locking nuts. If buckets are being installed on chain, use hex head bolts, nuts and washers. A locking device should always be used.

ADAPTER PLATES: Recommended for chain mounting applications.

FDA: Both the urethane and polyethylene are designed to FDA specifications for direct contact with food products.

SPACING: PROJECTION x 2 = STANDARD VERTICAL SPACING (depending on materials and speeds, closer or wider spacing may be used).

TIGER-TUFF® INDUSTRIAL

Nylon

**NEW SIZES!
ENHANCED
DESIGNS**

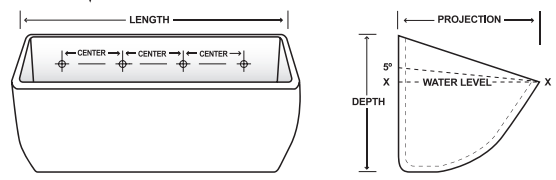

Available Materials:

TIGER-TUFF® INDUSTRIAL: Nylon

| BUCKET SIZE, INCHES* | | | | | WEIGHT, LBS | CAPACITY, CU. IN. | | |
|----------------------|--------|--------|-------|---------------------|-------------|--------------------------|--------------------------|-------------|
| BUCKET SIZE | Length | Proj. | Depth | Back Wall Thickness | Nylon | Water Level X-X, Cu. In. | Water Level X-X, Cu. Ft. | Std Spacing |
| 6 x 5 | 6 5/8 | 5 3/4 | 5 | 0.33 | 1.08 | 67.20 | 0.039 | 10 |
| 7 x 5 | 7 5/8 | 5 3/4 | 5 | 0.33 | 1.26 | 79.72 | 0.046 | 10 |
| 8 x 5 | 8 5/8 | 5 3/4 | 5 | 0.33 | 1.44 | 88.54 | 0.051 | 10 |
| 9 x 5 | 9 5/8 | 5 3/4 | 5 | 0.33 | 1.62 | 107.37 | 0.062 | 10 |
| 10 x 5 | 10 5/8 | 5 3/4 | 5 | 0.33 | 1.80 | 121.30 | 0.070 | 10 |
| 11 x 5 | 11 5/8 | 5 3/4 | 5 | 0.33 | 1.98 | 140.70 | 0.081 | 10 |
| 12 x 5 | 12 5/8 | 5 3/4 | 5 | 0.33 | 2.16 | 159.87 | 0.093 | 10 |
| 8 x 6 | 8 5/8 | 6 7/8 | 6 | 0.40 | 2.09 | 135.56 | 0.078 | 12 |
| 9 x 6 | 9 5/8 | 6 7/8 | 6 | 0.40 | 2.26 | 150.26 | 0.087 | 12 |
| 10 x 6 | 10 5/8 | 6 7/8 | 6 | 0.40 | 2.44 | 170.69 | 0.099 | 12 |
| 11 x 6 | 11 5/8 | 6 7/8 | 6 | 0.40 | 2.63 | 185.18 | 0.107 | 12 |
| 12 x 6 | 12 5/8 | 6 7/8 | 6 | 0.40 | 2.81 | 200.37 | 0.116 | 12 |
| 13 x 6 | 13 5/8 | 6 7/8 | 6 | 0.40 | 2.99 | 220.78 | 0.123 | 12 |
| 12 x 7 | 12 7/8 | 7 7/8 | 7 | 0.42 | 4.12 | 269.24 | 0.156 | 14 |
| 13 x 7 | 13 7/8 | 7 7/8 | 7 | 0.42 | 4.44 | 292.51 | 0.169 | 14 |
| 14 x 7 | 14 7/8 | 7 7/8 | 7 | 0.42 | 4.72 | 315.77 | 0.183 | 14 |
| 15 x 7 | 15 7/8 | 7 7/8 | 7 | 0.42 | 5.15 | 346.64 | 0.201 | 14 |
| 16 x 7 | 16 7/8 | 7 7/8 | 7 | 0.42 | 5.37 | 377.41 | 0.218 | 14 |
| 11 x 8 | 11 7/8 | 8 7/8 | 8 1/4 | 0.50 | 5.16 | 340.02 | 0.197 | 16 |
| 12 x 8 | 12 7/8 | 8 7/8 | 8 1/4 | 0.50 | 5.42 | 373.00 | 0.216 | 16 |
| 13 x 8 | 13 7/8 | 8 7/8 | 8 1/4 | 0.50 | 5.66 | 404.85 | 0.234 | 16 |
| 14 x 8 | 14 7/8 | 8 7/8 | 8 1/4 | 0.50 | 6.09 | 436.80 | 0.253 | 16 |
| 16 x 8 | 17 | 9 1/4 | 8 1/4 | 0.50 | 6.18 | 512.57 | 0.297 | 16 |
| 18 x 8 | 19 | 9 1/4 | 8 1/4 | 0.50 | 6.91 | 567.49 | 0.328 | 20 |
| 20 x 8 | 21 | 9 1/4 | 8 1/4 | 0.50 | 7.51 | 646.81 | 0.374 | 20 |
| 22 x 8 | 23 | 9 1/4 | 8 1/4 | 0.50 | 9.23 | 701.90 | 0.406 | 20 |
| 24 x 8 | 25 | 9 1/4 | 8 1/4 | 0.50 | 9.55 | 763.40 | 0.441 | 20 |
| 16 x 10 | 17 | 11 1/4 | 10 | 0.75 | 10.03 | 795.70 | 0.461 | 20 |
| 18 x 10 | 19 | 11 1/4 | 10 | 0.75 | 11.13 | 910.00 | 0.527 | 20 |
| 20 x 10 | 21 | 11 1/4 | 10 | 0.75 | 12.05 | 1032.50 | 0.598 | 20 |

■ New Sizes ■ Enhanced Designs. Disclaimer: New weights, dimensions, & capacities are estimated. Actual measurements may vary. *Some sizes are made to order. *Injection molded materials shrink at differing rates. External dimensions may vary. For tight tolerances, contact Maxi-Lift for additional information. Please contact Maxi-Lift for the most updated information. *Tiger-Tuff Industrial buckets must have metal adapter plates for chain.

Slow Speed Centrifugal Discharge 125-450 FPM

TIGER-TUFF® INDUSTRIAL

FDA Nylon

All Special Run-minimum quantities and set up fees may occur

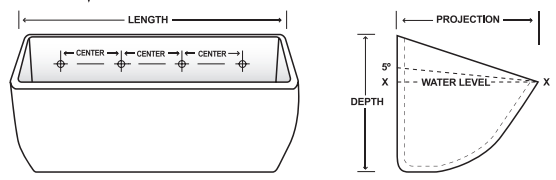

Available Materials:

TIGER-TUFF® INDUSTRIAL: FDA Nylon

| BUCKET SIZE, INCHES* | | | | | WEIGHT, LBS | CAPACITY, CU. IN. | | |
|----------------------|--------|--------|-------|---------------------|-------------|--------------------------|--------------------------|-------------|
| BUCKET SIZE | Length | Proj. | Depth | Back Wall Thickness | FDA Nylon | Water Level X-X, Cu. In. | Water Level X-X, Cu. Ft. | Std Spacing |
| 6 x 5 | 6 5/8 | 5 3/4 | 5 | 0.33 | 1.08 | 67.20 | 0.039 | 10 |
| 7 x 5 | 7 5/8 | 5 3/4 | 5 | 0.33 | 1.26 | 79.72 | 0.046 | 10 |
| 8 x 5 | 8 5/8 | 5 3/4 | 5 | 0.33 | 1.44 | 88.54 | 0.051 | 10 |
| 9 x 5 | 9 5/8 | 5 3/4 | 5 | 0.33 | 1.62 | 107.37 | 0.062 | 10 |
| 10 x 5 | 10 5/8 | 5 3/4 | 5 | 0.33 | 1.80 | 121.30 | 0.07 | 10 |
| 11 x 5 | 11 5/8 | 5 3/4 | 5 | 0.33 | 1.98 | 140.70 | 0.081 | 10 |
| 12 x 5 | 12 5/8 | 5 3/4 | 5 | 0.33 | 2.16 | 159.87 | 0.093 | 10 |
| 8 x 6 | 8 5/8 | 6 7/8 | 6 | 0.40 | 2.09 | 135.56 | 0.078 | 12 |
| 9 x 6 | 9 5/8 | 6 7/8 | 6 | 0.40 | 2.26 | 150.26 | 0.087 | 12 |
| 10 x 6 | 10 5/8 | 6 7/8 | 6 | 0.40 | 2.44 | 170.69 | 0.099 | 12 |
| 11 x 6 | 11 5/8 | 6 7/8 | 6 | 0.40 | 2.63 | 185.18 | 0.107 | 12 |
| 12 x 6 | 12 5/8 | 6 7/8 | 6 | 0.40 | 2.81 | 200.37 | 0.116 | 12 |
| 13 x 6 | 13 5/8 | 6 7/8 | 6 | 0.40 | 2.99 | 220.78 | 0.123 | 12 |
| 12 x 7 | 12 7/8 | 7 7/8 | 7 | 0.42 | 4.12 | 269.24 | 0.156 | 14 |
| 13 x 7 | 13 7/8 | 7 7/8 | 7 | 0.42 | 4.44 | 292.51 | 0.169 | 14 |
| 14 x 7 | 14 7/8 | 7 7/8 | 7 | 0.42 | 4.72 | 315.77 | 0.183 | 14 |
| 15 x 7 | 15 7/8 | 7 7/8 | 7 | 0.42 | 5.15 | 346.64 | 0.201 | 14 |
| 16 x 7 | 16 7/8 | 7 7/8 | 7 | 0.42 | 5.37 | 377.41 | 0.218 | 14 |
| 11 x 8 | 11 7/8 | 8 7/8 | 8 1/4 | 0.50 | 5.16 | 340.02 | 0.197 | 16 |
| 12 x 8 | 12 7/8 | 8 7/8 | 8 1/4 | 0.50 | 5.42 | 373.00 | 0.216 | 16 |
| 13 x 8 | 13 7/8 | 8 7/8 | 8 1/4 | 0.50 | 5.66 | 404.85 | 0.234 | 16 |
| 14 x 8 | 14 7/8 | 8 7/8 | 8 1/4 | 0.50 | 6.09 | 436.80 | 0.253 | 16 |
| 16 x 8 | 17 | 9 1/4 | 8 1/4 | 0.50 | 6.18 | 512.57 | 0.297 | 16 |
| 18 x 8 | 19 | 9 1/4 | 8 1/4 | 0.50 | 6.91 | 567.49 | 0.328 | 20 |
| 20 x 8 | 21 | 9 1/4 | 8 1/4 | 0.50 | 7.51 | 646.81 | 0.374 | 20 |
| 22 x 8 | 23 | 9 1/4 | 8 1/4 | 0.50 | 9.23 | 701.90 | 0.406 | 20 |
| 24 x 8 | 25 | 9 1/4 | 8 1/4 | 0.50 | 9.55 | 763.40 | 0.441 | 20 |
| 16 x 10 | 17 | 11 1/4 | 10 | 0.75 | 10.03 | 795.70 | 0.461 | 20 |
| 18 x 10 | 19 | 11 1/4 | 10 | 0.75 | 11.13 | 910.00 | 0.527 | 20 |
| 20 x 10 | 21 | 11 1/4 | 10 | 0.75 | 12.05 | 1032.50 | 0.598 | 20 |

■ New Sizes ■ Enhanced Designs. Disclaimer: New weights, dimensions, & capacities are estimated. Actual measurements may vary. *Some sizes are made to order. *Injection molded materials shrink at differing rates. External dimensions may vary. For tight tolerances, contact Maxi-Lift for additional information. Please contact Maxi-Lift for the most updated information. *Tiger-Tuff Industrial buckets must have metal adapter plates for chain.

Slow Speed Centrifugal Discharge 125-450 FPM

TIGER-TUFF® INDUSTRIAL

Urethane



**NEW SIZES!
ENHANCED
DESIGNS**



TIGER-TUFF
INDUSTRIAL ELEVATOR BUCKETS®

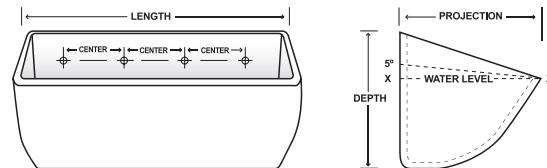

Available Materials:

TIGER-TUFF® INDUSTRIAL: Urethane

| BUCKET SIZE, INCHES* | | | | | WEIGHT, LBS | CAPACITY, CU. IN. | | |
|----------------------|--------|--------|-------|---------------------|-------------|--------------------------|--------------------------|-------------|
| BUCKET SIZE | Length | Proj. | Depth | Back Wall Thickness | Urethane | Water Level X-X, Cu. In. | Water Level X-X, Cu. Ft. | Std Spacing |
| 6 x 5 | 6 5/8 | 5 3/4 | 5 | 0.33 | 1.18 | 67.20 | 0.039 | 10 |
| 7 x 5 | 7 5/8 | 5 3/4 | 5 | 0.33 | 1.38 | 79.72 | 0.046 | 10 |
| 8 x 5 | 8 5/8 | 5 3/4 | 5 | 0.33 | 1.57 | 88.54 | 0.051 | 10 |
| 9 x 5 | 9 5/8 | 5 3/4 | 5 | 0.33 | 1.77 | 107.37 | 0.062 | 10 |
| 10 x 5 | 10 5/8 | 5 3/4 | 5 | 0.33 | 1.97 | 121.30 | 0.07 | 10 |
| 11 x 5 | 11 5/8 | 5 3/4 | 5 | 0.33 | 2.16 | 140.70 | 0.081 | 10 |
| 12 x 5 | 12 5/8 | 5 3/4 | 5 | 0.33 | 2.36 | 159.87 | 0.093 | 10 |
| 8 x 6 | 8 5/8 | 6 7/8 | 6 | 0.40 | 2.28 | 135.56 | 0.078 | 12 |
| 9 x 6 | 9 5/8 | 6 7/8 | 6 | 0.40 | 2.47 | 150.26 | 0.087 | 12 |
| 10 x 6 | 10 5/8 | 6 7/8 | 6 | 0.40 | 2.67 | 170.69 | 0.099 | 12 |
| 11 x 6 | 11 5/8 | 6 7/8 | 6 | 0.40 | 2.87 | 185.18 | 0.107 | 12 |
| 12 x 6 | 12 5/8 | 6 7/8 | 6 | 0.40 | 3.05 | 200.37 | 0.116 | 12 |
| 13 x 6 | 13 5/8 | 6 7/8 | 6 | 0.40 | 3.25 | 220.78 | 0.123 | 12 |
| 12 x 7 | 12 7/8 | 7 7/8 | 7 | 0.42 | 4.48 | 269.24 | 0.156 | 14 |
| 13 x 7 | 13 7/8 | 7 7/8 | 7 | 0.42 | 4.82 | 292.51 | 0.169 | 14 |
| 14 x 7 | 14 7/8 | 7 7/8 | 7 | 0.42 | 5.14 | 315.77 | 0.183 | 14 |
| 15 x 7 | 15 7/8 | 7 7/8 | 7 | 0.42 | 5.56 | 346.64 | 0.201 | 14 |
| 16 x 7 | 16 7/8 | 7 7/8 | 7 | 0.42 | 5.79 | 377.41 | 0.218 | 14 |
| 11 x 8 | 11 7/8 | 8 7/8 | 8 1/4 | 0.50 | 6.02 | 340.02 | 0.197 | 16 |
| 12 x 8 | 12 7/8 | 8 7/8 | 8 1/4 | 0.50 | 6.36 | 373.00 | 0.216 | 16 |
| 13 x 8 | 13 7/8 | 8 7/8 | 8 1/4 | 0.50 | 6.65 | 404.85 | 0.234 | 16 |
| 14 x 8 | 14 7/8 | 8 7/8 | 8 1/4 | 0.50 | 7.15 | 436.80 | 0.253 | 16 |
| 16 x 8 | 17 | 9 1/4 | 8 1/4 | 0.50 | 7.51 | 512.57 | 0.297 | 16 |
| 18 x 8 | 19 | 9 1/4 | 8 1/4 | 0.50 | 8.08 | 567.49 | 0.328 | 20 |
| 20 x 8 | 21 | 9 1/4 | 8 1/4 | 0.50 | 8.80 | 646.81 | 0.374 | 20 |
| 22 x 8 | 23 | 9 1/4 | 8 1/4 | 0.50 | 11.02 | 701.90 | 0.406 | 20 |
| 24 x 8 | 25 | 9 1/4 | 8 1/4 | 0.50 | 11.48 | 763.40 | 0.441 | 20 |
| 16 x 10 | 17 | 11 1/4 | 10 | 0.75 | 12.24 | 795.70 | 0.461 | 20 |
| 18 x 10 | 19 | 11 1/4 | 10 | 0.75 | 13.58 | 910.00 | 0.527 | 20 |
| 20 x 10 | 21 | 11 1/4 | 10 | 0.75 | 14.42 | 1032.50 | 0.598 | 20 |

■ New Sizes ■ Enhanced Designs. Disclaimer: New weights, dimensions, & capacities are estimated. Actual measurements may vary. *Some sizes are made to order. *Injection molded materials shrink at differing rates. External dimensions may vary. For tight tolerances, contact Maxi-Lift for additional information. Please contact Maxi-Lift for the most updated information. *Tiger-Tuff Industrial buckets must have metal adapter plates for chain.

Slow Speed Centrifugal Discharge 125-450 FPM

TIGER-TUFF® INDUSTRIAL

Polyethylene

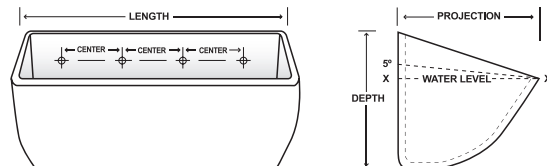

® The color orange, as applied to buckets, is a registered trademark of Maxi-Lift, Inc.

Available Materials:

TIGER-TUFF® INDUSTRIAL: Polyethylene

| BUCKET SIZE, INCHES* | | | | WEIGHT, LBS | CAPACITY, CU. IN. | | | |
|----------------------|--------|--------|-------|-------------|---------------------|---------|--------------------------|--------------------------|
| BUCKET SIZE | Length | Proj. | Depth | | Back Wall Thickness | HDPE | Water Level X-X, Cu. In. | Water Level X-X, Cu. Ft. |
| 6 x 5 | 6 5/8 | 5 3/4 | 5 | 0.33 | 0.94 | 67.20 | 0.039 | 10 |
| 7 x 5 | 7 5/8 | 5 3/4 | 5 | 0.33 | 1.10 | 79.72 | 0.046 | 10 |
| 8 x 5 | 8 5/8 | 5 3/4 | 5 | 0.33 | 1.25 | 88.54 | 0.051 | 10 |
| 9 x 5 | 9 5/8 | 5 3/4 | 5 | 0.33 | 1.41 | 107.37 | 0.062 | 10 |
| 10 x 5 | 10 5/8 | 5 3/4 | 5 | 0.33 | 1.57 | 121.30 | 0.07 | 10 |
| 11 x 5 | 11 5/8 | 5 3/4 | 5 | 0.33 | 1.72 | 140.70 | 0.081 | 10 |
| 12 x 5 | 12 5/8 | 5 3/4 | 5 | 0.33 | 1.88 | 159.87 | 0.093 | 10 |
| 8 x 6 | 8 5/8 | 6 7/8 | 6 | 0.40 | 1.82 | 135.56 | 0.078 | 12 |
| 9 x 6 | 9 5/8 | 6 7/8 | 6 | 0.40 | 1.97 | 150.26 | 0.087 | 12 |
| 10 x 6 | 10 5/8 | 6 7/8 | 6 | 0.40 | 2.13 | 170.69 | 0.099 | 12 |
| 11 x 6 | 11 5/8 | 6 7/8 | 6 | 0.40 | 2.29 | 185.18 | 0.107 | 12 |
| 12 x 6 | 12 5/8 | 6 7/8 | 6 | 0.40 | 2.44 | 200.37 | 0.116 | 12 |
| 13 x 6 | 13 5/8 | 6 7/8 | 6 | 0.40 | 2.60 | 220.78 | 0.123 | 12 |
| 12 x 7 | 12 7/8 | 7 7/8 | 7 | 0.42 | 3.60 | 269.24 | 0.156 | 14 |
| 13 x 7 | 13 7/8 | 7 7/8 | 7 | 0.42 | 3.86 | 292.51 | 0.169 | 14 |
| 14 x 7 | 14 7/8 | 7 7/8 | 7 | 0.42 | 4.14 | 315.77 | 0.183 | 14 |
| 15 x 7 | 15 7/8 | 7 7/8 | 7 | 0.42 | 4.47 | 346.64 | 0.201 | 14 |
| 16 x 7 | 16 7/8 | 7 7/8 | 7 | 0.42 | 4.68 | 377.41 | 0.218 | 14 |
| 11 x 8 | 11 7/8 | 8 7/8 | 8 1/4 | 0.50 | 4.45 | 340.02 | 0.197 | 16 |
| 12 x 8 | 12 7/8 | 8 7/8 | 8 1/4 | 0.50 | 4.71 | 373.00 | 0.216 | 16 |
| 13 x 8 | 13 7/8 | 8 7/8 | 8 1/4 | 0.50 | 4.92 | 404.85 | 0.234 | 16 |
| 14 x 8 | 14 7/8 | 8 7/8 | 8 1/4 | 0.50 | 5.30 | 436.80 | 0.253 | 16 |
| 16 x 8 | 17 | 9 1/4 | 8 1/4 | 0.50 | 5.35 | 512.57 | 0.297 | 16 |
| 18 x 8 | 19 | 9 1/4 | 8 1/4 | 0.50 | 5.89 | 567.49 | 0.328 | 20 |
| 20 x 8 | 21 | 9 1/4 | 8 1/4 | 0.50 | 6.62 | 646.81 | 0.374 | 20 |
| 22 x 8 | 23 | 9 1/4 | 8 1/4 | 0.50 | 7.85 | 701.90 | 0.406 | 20 |
| 24 x 8 | 25 | 9 1/4 | 8 1/4 | 0.50 | 8.50 | 763.40 | 0.441 | 20 |
| 16 x 10 | 17 | 11 1/4 | 10 | 0.75 | 8.87 | 795.70 | 0.461 | 20 |
| 18 x 10 | 19 | 11 1/4 | 10 | 0.75 | 9.83 | 910.00 | 0.527 | 20 |
| 20 x 10 | 21 | 11 1/4 | 10 | 0.75 | 10.57 | 1032.50 | 0.598 | 20 |

■ New Sizes ■ Enhanced Designs. Disclaimer: New weights, dimensions, & capacities are estimated. Actual measurements may vary. *Some sizes are made to order. *Injection molded materials shrink at differing rates. External dimensions may vary. For tight tolerances, contact Maxi-Lift for additional information. Please contact Maxi-Lift for the most updated information. *Tiger-Tuff Industrial buckets must have metal adapter plates for chain.

Slow Speed Centrifugal Discharge 125-450 FPM

TIGER-CC® INDUSTRIAL

Slow Speed Centrifugal Discharge 125-450 FPM

THE INDUSTRIAL TIGER-CC



TIGER-CC

INDUSTRIAL ELEVATOR BUCKETS®

THE INDUSTRIAL STRENGTH TIGER-CC

THICKER. TOUGHER. LASTS LONGER:
FOR THOSE WHO DON'T HAVE TIME
FOR DOWN-TIME

ENGINEERED FOR ULTIMATE RELIABILITY:
THE THICKEST FRONT LIP AND CORNERS
GIVE THE LONGEST BUCKET LIFE

ALL TIGER. ALL CC.



FEATURES & BENEFITS

- Largest Capacity - Move More Material in a Single Row
- Thicker Corners
- Thicker Walls, Heavy Front Lip for Digging
- Cleaner Discharge
- Heat, Impact & Abrasion Resistant
- Non-Corrosive, Non-Sparking
- Extends Bucket Life
- Increases Elevator Capacity
- Lowers Elevator Maintenance
- Decreases Elevator Down Time



Reinforced Corners



Heavy Front Lip



Traditional CC Breaks



Thick Back Wall

TIGER-CC® INDUSTRIAL

Slow Speed Centrifugal Discharge 125-450 FPM





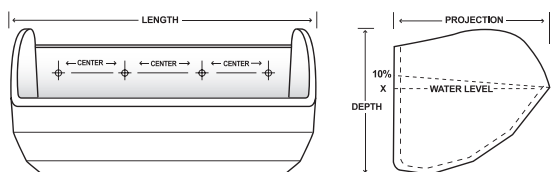

TIGER-CC® INDUSTRIAL

The **TIGER-CC** Industrial is a maximum duty industrial elevator bucket designed in the traditional CC style. The **TIGER-CC** is engineered to maximize bucket life and elevator capacity, reduce down time and lower maintenance costs. The **TIGER-CC** Industrial bucket has the thickest lip, back wall and corners to maximize bucket life and maintain capacity. Standard spacing is projection x 2. The most common applications include aggregate, sand, gravel, coal, gypsum, limestone, clay, cement and many, many more. The **TIGER-CC** Industrial is the maximum duty industrial bucket for your most demanding industrial applications.



AVAILABLE MATERIALS

| | NYLON | POLYETHYLENE | URETHANE | FDA NYLON |
|------------------------------|---|--|---|---|
| Color |  Tan |  Orange |  Green |  White |
| Application | Hot, high impact, abrasive, dense products | Food Products | Heavy abrasion, sticky materials | Hot, high impact, abrasive food grade products |
| Temperature Range | -60° F to + 300° F (350° F Intermittent) | -120° F to + 180° F (210° F Intermittent) | -60° F to + 180° F (210° F Intermittent) | -60° F to + 300° F |
| FDA Approved Material | No | Yes | Yes | Yes |
| Comments | Best for high heat applications, with tough impact and abrasion needs. | Economical, high density polyethylene. FDA approved material for handling food grade products. | Most flexible and abrasion resistant. Resists product sticking and sharp cutting particles. | Best for high heat applications, with tough impact and abrasion needs. |

APPLICATIONS



AGGREGATES

Asphalt, Clays, Coal, Limestone, Minerals, Ores, Silica Sand, Steel Shot, Wood Chips, etc.



POWDERS

Alumina, Bauxite, Cement, Chemicals, Fly Ash, Gypsum, Lime, Phosphates, Sawdust, etc.



AND MORE

Salt, Sugar, Cullet, Pellets, Fertilizer, Fullers Earth, etc.

OTHER CONSIDERATIONS

ENGINEERING: Please see Section 5 of catalog for detailed engineering, speed and capacity information.

DRILLING: Elevator Buckets are manufactured without a drill pattern. Special drilling or punching can be accommodated upon customer request.

*Mounting Holes drilled 1/32 to 1/16 over bolt diameter for easier installation.

VENTING: Available as needed. See venting options in this catalog.

DIGGER BUCKETS: Use slightly larger metal digger elevator buckets to help loosen material in the elevator boot section that has set up or hardened, thereby reducing abrasion on the plastic buckets. Call for details on Metal Digger elevator bucket options.

INSTALLATION: Use a #1 standard elevator bolt or Sabre-Tooth elevator bolt for installation. Designed to be used with fender or flat and lock washers and hex or locking nuts. If buckets are being installed on chain, use hex head bolts, nuts and washers. A locking device should always be used.

ADAPTER PLATES: Recommended for chain mounting applications.

FDA NYLON: Both the urethane and polyethylene are designed to FDA specifications for direct contact with food products.

SPACING: PROJECTION x 2 = STANDARD VERTICAL SPACING (depending on materials and speeds, closer or wider spacing may be used).

TIGER-CC® INDUSTRIAL

Nylon



**NEW SIZES!
ENHANCED
DESIGNS**

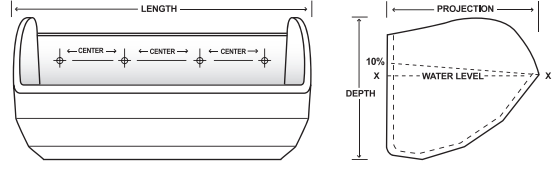

Available Materials:

TIGER-CC® INDUSTRIAL: Nylon

| BUCKET SIZE | BUCKET SIZE, INCHES* | | | | WEIGHT, LBS. | CAPACITY, CU. IN. | | |
|-------------|----------------------|--------|--------|----------------------|--------------|------------------------|-------------------------|-------------|
| | Length | Proj. | Depth | Back Wall Thick-ness | Nylon | Water Level X-X Cu. In | Water Level X-X Cu. Ft. | Std Spacing |
| 12 x 8 | 12-7/8 | 9-1/4 | 8-7/8 | 0.55 | - | 366 | 0.212 | 16 |
| 14 x 8 | 14-7/8 | 9-1/4 | 8-7/8 | 0.55 | - | 430 | 0.249 | 16 |
| 16 x 8 | 16-7/8 | 9-1/4 | 8-7/8 | 0.55 | - | 510 | 0.295 | 16 |
| 18 x 8 | 18-7/8 | 9-1/4 | 8-7/8 | 0.55 | - | 560 | 0.324 | 16 |
| 20 x 8 | 20-7/8 | 9-1/4 | 8-7/8 | 0.55 | 8.15 | 655 | 0.379 | 16 |
| 20 x 10 | 21 | 11-1/2 | 10-3/8 | 0.70 | - | 1005 | 0.581 | 20 |
| 21 x 10 | 22 | 11-1/2 | 10-3/8 | 0.70 | - | 1055 | 0.611 | 20 |
| 22 x 10 | 23 | 11-1/2 | 10-3/8 | 0.70 | - | 1105 | 0.639 | 20 |
| 23 x 10 | 24 | 11-1/2 | 10-3/8 | 0.70 | - | 1155 | 0.668 | 20 |
| 24 x 10 | 25 | 11-1/2 | 10-3/8 | 0.70 | - | 1206 | 0.698 | 20 |
| 25 x 10 | 26 | 11-1/2 | 10-3/8 | 0.70 | - | 1256 | 0.727 | 20 |
| 26 x 10 | 27 | 11-1/2 | 10-3/8 | 0.70 | - | 1306 | 0.756 | 20 |
| 27 x 10 | 28 | 11-1/2 | 10-3/8 | 0.70 | - | 1356 | 0.785 | 20 |
| 28 x 10 | 29 | 11-1/2 | 10-3/8 | 0.70 | - | 1400 | 0.810 | 20 |

Available upon request - extended lead time required.

* Injection molded materials shrink at differing rates. External dimensions may vary. For tight tolerances, contact Maxi-Lift for additional information. **Some sizes are made to order. Weights, Dimensions, and Capacities have been estimated from engineered elevator bucket drawings. Actual molded parts will vary from numbers on charts. Please contact Maxi-Lift for the most updated information.

Slow Speed Centrifugal Discharge 125-450 FPM

TIGER-CC® INDUSTRIAL

FDA Nylon

All Special Run-minimum quantities and set up fees may occur

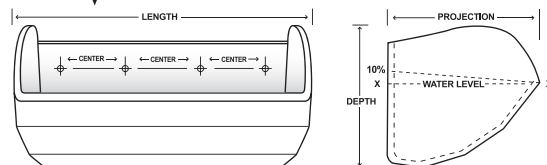

Available Materials:

TIGER-CC® INDUSTRIAL: FDA Nylon

| BUCKET SIZE | BUCKET SIZE, INCHES* | | | | WEIGHT, LBS. | CAPACITY, CU. IN. | | |
|-------------|----------------------|--------|--------|---------------------|--------------|------------------------|-------------------------|-------------|
| | Length | Proj. | Depth | Back Wall Thickness | FDA Nylon | Water Level X-X Cu. In | Water Level X-X Cu. Ft. | Std Spacing |
| 12 x 8 | 12-7/8 | 9-1/4 | 8-7/8 | 0.55 | - | 366 | 0.212 | 16 |
| 14 x 8 | 14-7/8 | 9-1/4 | 8-7/8 | 0.55 | - | 430 | 0.249 | 16 |
| 16 x 8 | 16-7/8 | 9-1/4 | 8-7/8 | 0.55 | - | 510 | 0.295 | 16 |
| 18 x 8 | 18-7/8 | 9-1/4 | 8-7/8 | 0.55 | - | 560 | 0.324 | 16 |
| 20 x 8 | 20-7/8 | 9-1/4 | 8-7/8 | 0.55 | 8.15 | 655 | 0.379 | 16 |
| 20 x 10 | 21 | 11-1/2 | 10-3/8 | 0.70 | - | 1005 | 0.581 | 20 |
| 21 x 10 | 22 | 11-1/2 | 10-3/8 | 0.70 | - | 1055 | 0.611 | 20 |
| 22 x 10 | 23 | 11-1/2 | 10-3/8 | 0.70 | - | 1105 | 0.639 | 20 |
| 23 x 10 | 24 | 11-1/2 | 10-3/8 | 0.70 | - | 1155 | 0.668 | 20 |
| 24 x 10 | 25 | 11-1/2 | 10-3/8 | 0.70 | - | 1206 | 0.698 | 20 |
| 25 x 10 | 26 | 11-1/2 | 10-3/8 | 0.70 | - | 1256 | 0.727 | 20 |
| 26 x 10 | 27 | 11-1/2 | 10-3/8 | 0.70 | - | 1306 | 0.756 | 20 |
| 27 x 10 | 28 | 11-1/2 | 10-3/8 | 0.70 | - | 1356 | 0.785 | 20 |
| 28 x 10 | 29 | 11-1/2 | 10-3/8 | 0.70 | - | 1400 | 0.810 | 20 |

Available upon request - extended lead time required.

* Injection molded materials shrink at differing rates. External dimensions may vary. For tight tolerances, contact Maxi-Lift for additional information. **Some sizes are made to order. Weights, Dimensions, and Capacities have been estimated from engineered elevator bucket drawings. Actual molded parts will vary from numbers on charts. Please contact Maxi-Lift for the most updated information.

Slow Speed Centrifugal Discharge 125-450 FPM

TIGER-CC® INDUSTRIAL

Urethane



**NEW SIZES!
ENHANCED
DESIGNS**

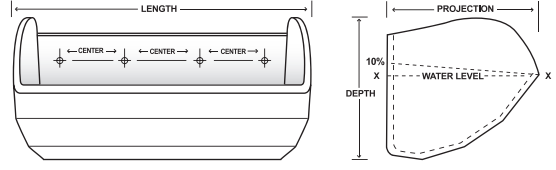

Available Materials:

TIGER-CC® INDUSTRIAL: Urethane

| BUCKET SIZE | BUCKET SIZE, INCHES* | | | | WEIGHT, LBS. | CAPACITY, CU. IN. | | |
|----------------|----------------------|--------|--------|---------------------|--------------|-------------------|------------------------|-------------------------|
| | Length | Proj. | Depth | Back Wall Thickness | | Urethane | Water Level X-X Cu. In | Water Level X-X Cu. Ft. |
| 12 x 8 | 12-7/8 | 9-1/4 | 8-7/8 | 0.55 | - | 366 | 0.212 | 16 |
| 14 x 8 | 14-7/8 | 9-1/4 | 8-7/8 | 0.55 | - | 430 | 0.249 | 16 |
| 16 x 8 | 16-7/8 | 9-1/4 | 8-7/8 | 0.55 | - | 510 | 0.295 | 16 |
| 18 x 8 | 18-7/8 | 9-1/4 | 8-7/8 | 0.55 | - | 560 | 0.324 | 16 |
| 20 x 8 | 20-7/8 | 9-1/4 | 8-7/8 | 0.55 | 9.58 | 655 | 0.379 | 16 |
| 20 x 10 | 21 | 11-1/2 | 10-3/8 | 0.70 | - | 1005 | 0.581 | 20 |

* Injection molded materials shrink at differing rates. External dimensions may vary. For tight tolerances, contact Maxi-Lift for additional information. **Some sizes are made to order. Weights, Dimensions, and Capacities have been estimated from engineered elevator bucket drawings. Actual molded parts will vary from numbers on charts. Please contact Maxi-Lift for the most updated information.

Slow Speed Centrifugal Discharge 125-450 FPM

TIGER-CC[®] INDUSTRIAL

Polyethylene

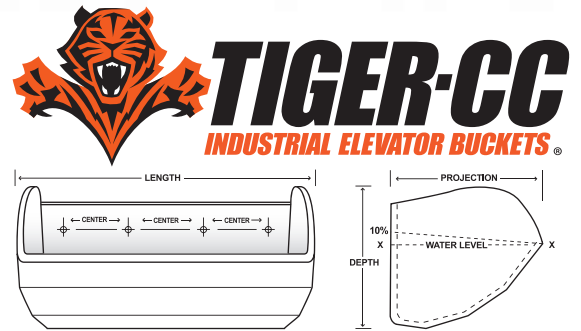

® The color orange, as applied to buckets, is a registered trademark of Maxi-Lift, Inc.

Available Materials:

TIGER-CC[®] INDUSTRIAL: Polyethylene

| BUCKET SIZE | BUCKET SIZE, INCHES* | | | | WEIGHT, LBS. | CAPACITY, CU. IN. | | |
|-------------|----------------------|--------|--------|---------------------|--------------|------------------------|-------------------------|-------------|
| | Length | Proj. | Depth | Back Wall Thickness | HDPE | Water Level X-X Cu. In | Water Level X-X Cu. Ft. | Std Spacing |
| 12 x 8 | 12-7/8 | 9-1/4 | 8-7/8 | 0.55 | 4.9 | 366 | 0.212 | 16 |
| 14 x 8 | 14-7/8 | 9-1/4 | 8-7/8 | 0.55 | 5.4 | 430 | 0.249 | 16 |
| 16 x 8 | 16-7/8 | 9-1/4 | 8-7/8 | 0.55 | 5.9 | 510 | 0.295 | 16 |
| 18 x 8 | 18-7/8 | 9-1/4 | 8-7/8 | 0.55 | 6.6 | 560 | 0.324 | 16 |
| 20 x 8 | 20-7/8 | 9-1/4 | 8-7/8 | 0.55 | 7.2 | 655 | 0.379 | 16 |
| 20 x 10 | 21 | 11-1/2 | 10-3/8 | 0.70 | 12.2 | 1005 | 0.581 | 20 |
| 21 x 10 | 22 | 11-1/2 | 10-3/8 | 0.70 | 12.6 | 1055 | 0.611 | 20 |
| 22 x 10 | 23 | 11-1/2 | 10-3/8 | 0.70 | 13.0 | 1105 | 0.639 | 20 |
| 23 x 10 | 24 | 11-1/2 | 10-3/8 | 0.70 | 13.5 | 1155 | 0.668 | 20 |
| 24 x 10 | 25 | 11-1/2 | 10-3/8 | 0.70 | 14.0 | 1206 | 0.698 | 20 |
| 25 x 10 | 26 | 11-1/2 | 10-3/8 | 0.70 | 14.4 | 1256 | 0.727 | 20 |
| 26 x 10 | 27 | 11-1/2 | 10-3/8 | 0.70 | 14.8 | 1306 | 0.756 | 20 |
| 27 x 10 | 28 | 11-1/2 | 10-3/8 | 0.70 | 15.3 | 1356 | 0.785 | 20 |
| 28 x 10 | 29 | 11-1/2 | 10-3/8 | 0.70 | 15.8 | 1400 | 0.810 | 20 |

Available upon request - extended lead time required

* Injection molded materials shrink at differing rates. External dimensions may vary. For tight tolerances, contact Maxi-Lift for additional information.

Weights, Dimensions, and Capacities have been estimated from engineered elevator bucket drawings. Actual molded parts will vary from numbers on charts. Please contact Maxi-Lift for the most updated information.

Slow Speed Centrifugal Discharge 125-450 FPM

DI-MAX® AA, AC & AA DIGGER

Ductile Iron Elevator Buckets

THE MAXI-LIFT DI-MAX

DUCTILE IRON AA & AC



**THERE'S DUCTILE IRON, AND THERE'S
MAXI-LIFT DUCTILE IRON:**
THE DI-MAX AA, AC & AA DIGGER BUCKETS
PERFORM AT THE TOP OF THEIR CLASS

OUTPERFORMS MALLEABLE IRON:
BETTER WEAR, MORE IMPACT
RESISTANCE

FEATURES & BENEFITS

- Mill Duty, Thick Walls with Reinforced Back and Corners
- Extremely High Impact and Abrasion Resistance
- Applications up to 600 Degrees
- Designed to Handle Sand, Glass Cullet, Stone, Shot Blast, Rock, Concrete and Other Abrasive Products
- Long Wearing Digging Edge
- Stronger than Steel of the Same Gauge
- Smooth Surface to Ensure Proper Filling
- Strong Impact and Abrasion Resistance for Long Life



Reinforced Corners - DIAA



Heavy Duty Back Wall



Heavy Front Lips



Heavy Front Lip - DIAC

DI-MAX® AA, AC & AA DIGGER

Ductile Iron Elevator Buckets



DI-MAX® AA & AA DIGGER, DI-MAX® AC

Designed to act as a Digger for MAXI-TUFF® AA Style plastic elevator buckets. The **DI-MAX AA** style ductile iron elevator buckets is engineered to exceed the performance requirements of any industrial application. These buckets are designed with thicker walls and a reinforced front lip to increase bucket life in tough industrial environments. Ductile iron is far superior to malleable iron in both impact and abrasion resistance. Replacing malleable iron with **DI-MAX** ductile iron elevator buckets will result in longer bucket life and more efficient operation.

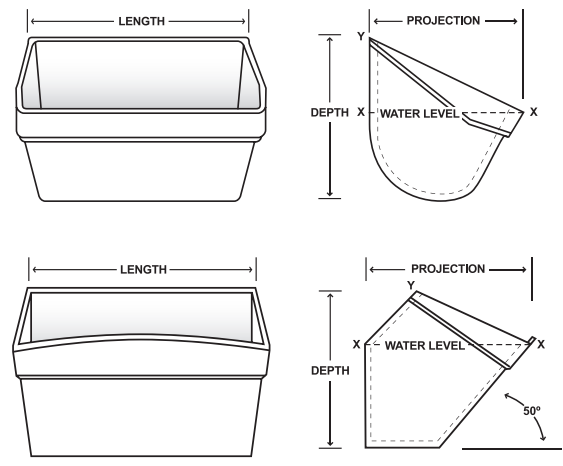

DI-MAX® DUCTILE IRON VS. MALLEABLE IRON

DI-MAX DUCTILE IRON

MALLEABLE IRON



Capacity: 67.0 cubic inches



Capacity: 23.1 cubic inches

WEAR AND CAPACITY COMPARISON

Run side by side in a durability test, the **DI-MAX** Ductile Iron Bucket demonstrates superior abrasion resistance, while the malleable bucket shows severe signs of wear. With a maximum volume of 67.0 cubic inches (compared to only 23.1 cubic inches for the malleable iron bucket) the **DI-MAX** delivers 65.5% more carrying capacity after an equal period of wear.

* Buckets run side by side on belt moving 1" minus aggregate 24 hours a day for a three month period of time.

| PERFORMANCE | DI-MAX DUCTILE IRON BUCKETS | DI-MAX DUCTILE IRON BUCKETS | DI-MAX DUCTILE IRON BUCKETS | DI-MAX DUCTILE IRON BUCKETS |
|-------------|-----------------------------|-----------------------------|-----------------------------|-----------------------------|
| Best | [DI-MAX Bucket] | | | |
| Better | [DI-MAX Bucket] | | | |
| Good | [DI-MAX Bucket] | | | |
| Fair | [DI-MAX Bucket] | [Malleable Bucket] | [DI-MAX Bucket] | [Malleable Bucket] |
| Poor | [DI-MAX Bucket] | [Malleable Bucket] | [DI-MAX Bucket] | [Malleable Bucket] |
| | ABRASION RESISTANCE | IMPACT RESISTANCE | CORROSION RESISTANCE | STRENGTH / WEIGHT |

 DI-MAX Ductile Iron Bucket  Competitors Malleable Iron Bucket

DI-MAX® AA, & AA DIGGER

Ductile Iron Elevator Buckets

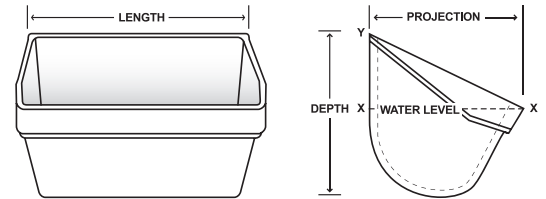

MOUNTING HOLES AND VENTING TO YOUR SPECIFICATIONS

DI-MAX® AA, DI-MAX® AA DIGGER

| BUCKET SIZE, INCHES | | | | THICKNESS | | | CAPACITY | | WEIGHT, LBS. |
|---------------------|--------|--------|--------|---------------------|------------------------|---------------------|----------------------|---------------------------|--------------|
| BUCKET SIZE | Length | Proj. | Depth | Back Wall Thickness | Front Corner Thickness | Front Lip Thickness | Water Cu. Inches X-X | 100% Gross Cu. Inches X-Y | |
| 4 x 3 | 4-1/2 | 3-3/8 | 3-1/2 | .185 | .275 | .250 | 17.10 | 24.20 | 1.7 |
| 6 x 4 | 6-1/2 | 4-3/8 | 4-1/2 | .250 | .350 | .275 | 42.30 | 63.50 | 3.8 |
| 7 x 4-1/2 | 7-1/2 | 4-3/8 | 4-1/2 | .250 | .350 | .275 | 49.50 | 76.20 | 4.0 |
| 7 x 5 | 7-7/8 | 5-1/8 | 5-1/2 | .250 | .250 | .210 | 68.60 | 102.90 | 6.1 |
| 8 x 5 | 8-1/2 | 5-3/8 | 5-1/2 | .250 | .400 | .375 | 83.10 | 126.30 | 6.5 |
| 9 x 5 | 9-1/2 | 5-3/8 | 5-1/2 | .250 | .400 | .375 | 90.70 | 138.80 | 7.5 |
| 11 x 5 | 11-7/8 | 5-1/4 | 5-1/2 | .210 | .250 | .210 | 102.60 | 153.90 | 7.0 |
| 15 x 5 | 15-7/8 | 5 | 5-1/2 | .210 | .400 | .350 | 154.20 | 235.90 | 10.7 |
| 19 x 5 | 19-7/8 | 5-1/4 | 5-1/2 | .250 | .400 | .350 | 198.20 | 303.20 | 14.1 |
| 9 x 6 | 9-5/8 | 6-3/8 | 6-1/2 | .300 | .400 | .375 | 124.70 | 190.80 | 10.2 |
| 10 x 6 | 10-5/8 | 6-3/8 | 6-1/2 | .300 | .400 | .375 | 143.40 | 219.70 | 11.2 |
| 11 x 6 | 11-5/8 | 6-3/8 | 6-1/2 | .300 | .400 | .375 | 159.80 | 244.50 | 12.2 |
| 12 x 6 | 12-5/8 | 6-3/8 | 6-1/2 | .300 | .400 | .375 | 175.40 | 268.30 | 13.1 |
| 12 x 7 | 12-5/8 | 7-3/8 | 7-1/2 | .330 | .625 | .450 | 219.70 | 350.90 | 18.5 |
| 14 x 7 | 14-5/8 | 7-3/8 | 7-1/2 | .330 | .625 | .450 | 265.20 | 407.00 | 20.4 |
| 16 x 7 | 16-5/8 | 7-3/8 | 7-1/2 | .330 | .625 | .450 | 301.20 | 460.90 | 22.9 |
| 14 x 8 | 14-5/8 | 8-3/8 | 8-1/2 | .375 | .625 | .500 | 366.00 | 526.00 | 24.6 |
| 16 x 8 | 16-5/8 | 8-3/8 | 8-1/2 | .375 | .625 | .500 | 381.40 | 599.20 | 26.8 |
| 18 x 8 | 18-5/8 | 8-3/8 | 8-1/2 | .375 | .625 | .525 | 450.30 | 695.00 | 30.0 |
| 20 x 8 | 20-5/8 | 8-3/8 | 8-1/2 | .375 | .625 | .525 | 499.30 | 763.90 | 34.3 |
| 24 x 8 | 24-5/8 | 8-3/8 | 8-1/2 | .375 | .625 | .525 | 597.40 | 914.00 | 42.9 |
| 18 x 10 | 18-3/4 | 10-3/8 | 10-1/2 | .440 | .800 | .750 | 661.50 | 1012.90 | 44.6 |

* Actual dimensions may vary slightly on all elevator buckets, depending on specified raw material.

DI-MAX[®] AC

Ductile Iron Elevator Buckets

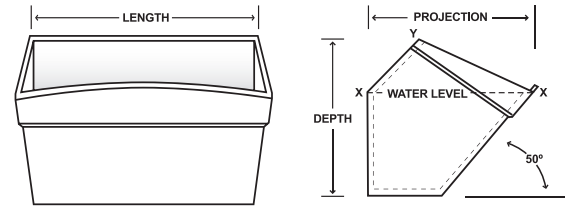

MOUNTING HOLES AND VENTING TO YOUR SPECIFICATIONS

DI-MAX[®] AC

| BUCKET SIZE, INCHES | | | | THICKNESS | | | CAPACITY | | WEIGHT, LBS. |
|---------------------|--------|--------|-------|---------------------|------------------------|---------------------|----------------------|---------------------------|--------------|
| BUCKET SIZE | Length | Proj. | Depth | Back Wall Thickness | Front Corner Thickness | Front Lip Thickness | Water Cu. Inches X-X | 100% Gross Cu. Inches X-Y | |
| 12 x 8 | 12-1/2 | 9-1/4 | 9 | .425 | .575 | .550 | 368.90 | 472.40 | 28 |
| 16 x 8 | 16-1/2 | 9-1/4 | 9 | .425 | .600 | .550 | 508.10 | 651.40 | 38 |
| 18 x 10 | 18-3/4 | 11-1/2 | 11 | .550 | .675 | .700 | 874.50 | 1139.20 | 70 |
| 24 x 10 | 24-3/4 | 11-3/4 | 11 | .410 | .725 | .600 | 1231.60 | 1570.90 | 72 |

* Actual dimensions may vary slightly on all elevator buckets, depending on specified raw material.

AA DIGGER

Industrial Welded Metal Elevator Buckets



WELDED STEEL

AA DIGGER WELDED STEEL

AA Digger Buckets are manufactured to fit with **MAXI-TUFF AA** plastic elevator buckets but are 1/4" to 1/2" longer in length and projection. The **AA Digger Bucket** clears a path through the boot section of the elevator in order to remove excess material and reduce wear. Digger buckets are mounted every fifth to every tenth space between the **MAXI-TUFF AA** plastic buckets. **AA Digger Buckets** will extend the life of the **MAXI-TUFF AA** buckets in materials that pack or cake tightly in the boot section.

FEATURES & BENEFITS

- Thick Reinforced Lip
- Buckets Continuously Welded
- Works with **MAXI-TUFF AA** or **Welded Steel Buckets**
- Long Wearing Digging Edge
- Smooth Surface to Ensure Proper Filling
- Strong Impact and Abrasion Resistance for Long Life
- Carbon or Stainless Steel
- Options: **AR Plate, Hardened Surface or Hard Bead Weld**
- Designed To Handle Sand, Glass Cullet, Stone, Shot Blast, Rock, Concrete and Other Abrasive Products

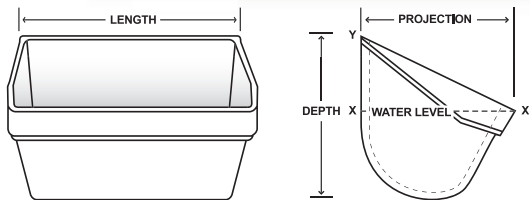

MOUNTING HOLES AND VENTING TO YOUR SPECIFICATIONS

AA DIGGER

| BUCKET SIZE, INCHES | | | | WEIGHT, LBS. | | | | CAPACITY, CU. FT.* | |
|---------------------|--------|--------|--------|----------------|----------------|---------------|------------|--------------------|--------------------|
| BUCKET SIZE | Length | Proj. | Depth | 12 Gauge Steel | 10 Gauge Steel | 7 Gauge Steel | 1/4" Steel | Filled to Line X-X | Filled to Line X-Y |
| 4 x 3 | 4-3/4 | 3-3/8 | 3-1/8 | 1.35 | 1.80 | 2.35 | - | 0.01 | 0.01 |
| 5 x 4 | 5-3/4 | 4-3/8 | 4-1/8 | 2.25 | 2.65 | 3.50 | - | 0.01 | 0.02 |
| 6 x 4 | 6-3/4 | 4-3/8 | 4-1/8 | 2.75 | 3.25 | 4.20 | 5.50 | 0.02 | 0.05 |
| 7 x 4 | 7-3/4 | 4-3/8 | 4-1/8 | 3.00 | 3.95 | 5.50 | 7.30 | 0.04 | 0.05 |
| 7 x 5 | 7-5/8 | 5-3/8 | 5-1/4 | 3.75 | 4.75 | 6.50 | 8.35 | 0.04 | 0.06 |
| 8 x 5 | 8-5/8 | 5-3/8 | 5-1/4 | 4.25 | 5.45 | 7.15 | 9.45 | 0.05 | 0.08 |
| 9 x 5 | 9-5/8 | 5-3/8 | 5-1/4 | 4.95 | 6.25 | 8.05 | 10.45 | 0.05 | 0.08 |
| 9 x 6 | 9-7/8 | 6-3/8 | 6-1/8 | 5.60 | 7.00 | 9.30 | 12.20 | 0.07 | 0.12 |
| 10 x 6 | 10-7/8 | 6-3/8 | 6-1/8 | 6.10 | 7.70 | 10.10 | 13.35 | 0.08 | 0.13 |
| 11 x 6 | 11-7/8 | 6-3/8 | 6-1/8 | 6.60 | 8.40 | 10.90 | 14.40 | 0.09 | 0.14 |
| 12 x 6 | 12-7/8 | 6-3/8 | 6-1/8 | 7.10 | 9.00 | 11.80 | 15.55 | 0.10 | 0.15 |
| 12 x 7 | 12-7/8 | 7-3/8 | 7-1/8 | 8.75 | 11.05 | 14.55 | 19.05 | 0.13 | 0.21 |
| 14 x 7 | 14-7/8 | 7-3/8 | 7-1/8 | - | 12.35 | 16.35 | 21.45 | 0.15 | 0.24 |
| 14 x 8 | 14-7/8 | 8-3/8 | 8-1/8 | - | 14.35 | 19.30 | 25.45 | 0.21 | 0.33 |
| 16 x 8 | 16-7/8 | 8-3/8 | 8-1/8 | - | 16.05 | 21.30 | 28.25 | 0.24 | 0.38 |
| 18 x 8 | 18-5/8 | 8-3/8 | 8-1/8 | - | 17.55 | 23.30 | 30.80 | 0.27 | 0.43 |
| 18 x 10 | 19 | 10-3/8 | 10-1/8 | - | 22.05 | 29.45 | 39.40 | 0.35 | 0.66 |

*Weights are estimated. ** Made to order. Available in other sizes. ***Style A also available (w/o reinforced lip)

AA WELDED STEEL

Industrial Welded Metal Elevator Buckets



WELDED STEEL

AA WELDED STEEL

AA Welded Steel generally utilize a 3-piece construction; the end caps fit on the outside of the body and are continuously welded to the body. There generally is no taper on the sides of the bucket. The reinforced wear lip is attached to the front of the bucket.

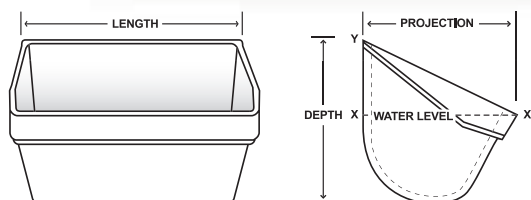

MOUNTING HOLES AND VENTING TO YOUR SPECIFICATIONS

FEATURES & BENEFITS

- Thick Reinforced Lip for Superior Abrasion Resistance
- Resistance to Distortion From Scooping Heavy or Packed Materials
- Typical in Sand, Glass or Gravel
- Long Wearing Digging Edge
- Buckets are Continuously Welded
- Mounted on Chain Or Belt
- Options: Carbon Steel, Aluminum, Stainless Steel, AR Plate, Wear Lips, Hardened Surface and Hard Bead Weld
- Buckets Available in 14ga, 12ga, 10ga, 7ga, 1/4", 5/16", 3/8", 1/2" Steel

AA WELDED STEEL

| BUCKET SIZE, INCHES | | | | WEIGHT, LBS. | | | | CAPACITY, CU. FT.* | |
|---------------------|--------|-------|--------|----------------|----------------|-------------|------------|--------------------|--------------------|
| BUCKET SIZE | Length | Proj. | Depth | 12 Gauge Steel | 10 Gauge Steel | 3/16" Steel | 1/4" Steel | Filled to Line X-X | Filled to Line X-Y |
| 4 x 2 3/4 | 4 | 2-3/4 | 3 | 1.15 | 1.48 | 1.95 | - | 0.006 | 0.009 |
| 5 x 3 1/2 | 5 | 3-1/2 | 3-3/4 | 1.81 | 2.33 | 3.15 | - | 0.013 | 0.022 |
| 6 x 4 | 6 | 4 | 4-1/4 | 2.35 | 3.02 | 3.96 | 5.27 | 0.020 | 0.032 |
| 7 x 4 1/2 | 7 | 4-1/2 | 5 | 3.17 | 4.08 | 5.35 | 7.12 | 0.034 | 0.051 |
| 8 x 5 | 8 | 5 | 5-1/2 | 4.15 | 5.33 | 7.06 | 9.39 | 0.047 | 0.072 |
| 10 x 6 | 10 | 6 | 6-1/4 | 5.73 | 7.37 | 9.79 | 13.02 | 0.076 | 0.120 |
| 11 x 6 | 11 | 6 | 6-1/4 | 6.16 | 7.93 | 10.46 | 13.91 | 0.084 | 0.133 |
| 12 x 6 | 12 | 6 | 6-1/4 | 6.60 | 8.49 | 11.29 | 15.02 | 0.091 | 0.145 |
| 12 x 7 | 12 | 7 | 7-1/4 | 8.11 | 10.42 | 13.93 | 18.53 | 0.124 | 0.199 |
| 14 x 7 | 14 | 7 | 7-1/4 | - | 11.72 | 15.70 | 20.88 | 0.145 | 0.232 |
| 14 x 8 | 14 | 8 | 8-1/2 | - | 13.9 | 18.64 | 24.80 | 0.202 | 0.316 |
| 15 x 7 | 15 | 7 | 7-1/4 | - | 12.37 | 16.58 | 22.05 | 0.155 | 0.248 |
| 16 x 7 | 16 | 7 | 7-1/4 | - | 13.03 | 17.47 | 23.24 | 0.165 | 0.265 |
| 16 x 8 | 16 | 8 | 8-1/2 | - | 15.41 | 20.67 | 27.49 | 0.231 | 0.362 |
| 18x8 | 18 | 8 | 8-1/2 | - | 16.92 | 22.70 | 30.19 | 0.260 | 0.407 |
| 18x10 | 18 | 10 | 10-1/2 | - | 21.48 | 28.88 | 38.41 | 0.336 | 0.632 |
| 20 x 8 | 20 | 8 | 8-1/2 | - | 18.42 | 24.74 | 32.90 | 0.289 | 0.452 |
| 24 x 8 | 24 | 8 | 8-1/2 | - | 21.43 | 28.81 | 38.32 | 0.347 | 0.543 |

* Weights are estimated. ** Made to order. Available in other sizes.

AC WELDED STEEL

Industrial Welded Metal Elevator Buckets



WELDED STEEL

AC WELDED STEEL

AC Welded Steel buckets generally utilize a 3-piece construction; the end caps fit on the outside of the body and are continuously welded to the body. There generally is no taper on the sides of the bucket. There is approximately a 50° angle from the horizontal to the front plate.

FEATURES & BENEFITS

- High Front for Greater Capacity
- Buckets are Continuously Welded
- Hooded Back for Closer Spacing
- Typical In Cement, Gypsum or Other Powdery Materials
- Mounted on Chain or Belt
- Venting Available for Clean Filling and Discharge
- Options: Carbon Steel, Aluminum, Stainless Steel, AR Plate, Wear Lips, Hardened Surface and Hard Bead Weld
- Buckets Available In 14ga, 12ga, 10ga, 7ga, 1/4", 5/16", 3/8", 1/2" Steel

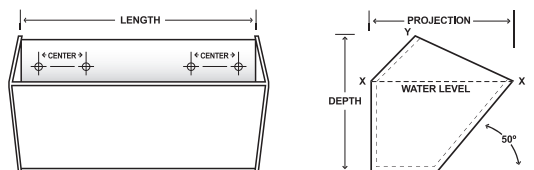

MOUNTING HOLES AND VENTING TO YOUR SPECIFICATIONS

AC WELDED STEEL

| BUCKET SIZE | BUCKET SIZE, INCHES | | | WEIGHT, LBS. | | CAPACITY, CU. FT.* | |
|-------------|---------------------|-------|--------|--------------|------------|--------------------|--------------------|
| | Length | Proj. | Depth | 3/16" Steel | 1/4" Steel | Filled to Line X-X | Filled to Line X-Y |
| 12 x 8 | 12 | 8 | 8-1/2 | 18.25 | 24.30 | 0.231 | 0.303 |
| 14 x 8 | 14 | 8 | 8-1/2 | 20.30 | 27.00 | 0.271 | 0.356 |
| 16 x 8 | 16 | 8 | 8-1/2 | 22.48 | 29.98 | 0.311 | 0.408 |
| 18 x 10 | 18 | 10 | 10-1/2 | 31.15 | 38.95 | 0.488 | 0.691 |
| 20 x 10 | 20 | 10 | 10-1/2 | 33.68 | 42.10 | 0.542 | 0.768 |
| 24 x 10 | 24 | 10 | 10-1/2 | 39.67 | 52.69 | 0.651 | 0.921 |
| 27 x 12 | 27 | 12 | 12-1/2 | 53.84 | 71.46 | 1.072 | 1.474 |

* Weights are estimated and do not include bolt reinforcing plates. Bolt reinforcing plates are recommended if less than 8 bolts are used. Vent holes in bottom are optional in style AC buckets.

** Made to order. Available in other sizes.

SC WELDED STEEL

Industrial Welded Metal Elevator Buckets

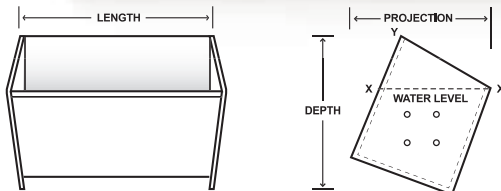

MOUNTING HOLES AND VENTING TO YOUR SPECIFICATIONS

WELDED STEEL

SC WELDED STEEL

SC Welded Steel buckets generally utilize a 3-piece construction; the end caps fit on the outside of the body and are continuously welded to the body. There generally is no taper on the sides of the bucket.

FEATURES & BENEFITS

- Mounted Between Two Strands of Chain
- Suitable for Heaviest Materials
- Designed for Super Capacity Elevators
- Buckets are Continuously Welded
- Design Offers Increased Capacity
- Typical in Aggregate and Cement Applications
- Options: Carbon Steel, Aluminum, Stainless Steel, AR Plate, Wear Lips, Hardened Surface and Hard Bead Weld
- Buckets Available In 14ga, 12ga, 10ga, 7ga, 1/4", 5/16", 3/8", 1/2" Steel
- See punching for chain and belt

SC WELDED STEEL

| BUCKET SIZE, INCHES | | | | WEIGHT, LBS | | | CAPACITY, CU. FT.* | |
|---------------------|--------|-------|--------|----------------|-------------|------------|--------------------|--------------------|
| BUCKET SIZE | Length | Proj. | Depth | 10 Gauge Steel | 3/16" Steel | 1/4" Steel | Filled to Line X-X | Filled to Line X-Y |
| 12 x 8 x 11 | 12 | 8-3/4 | 11-5/8 | 22 | 29 | 39 | 0.35 | 0.54 |
| 14 x 8 x 11 | 14 | 8-3/4 | 11-5/8 | 23 | 31 | 41 | 0.41 | 0.63 |
| 16 x 8 x 11 | 16 | 8-3/4 | 11-5/8 | 25 | 34 | 45 | 0.46 | 0.72 |
| 16 x 12 x 17 | 16 | 12 | 17-5/8 | 43 | 58 | 76 | 1.11 | 1.55 |
| 18 x 8 x 11 | 18 | 8-3/4 | 11-5/8 | 27 | 36 | 48 | 0.52 | 0.81 |
| 20 x 8 x 11 | 20 | 8-3/4 | 11-5/8 | 29 | 39 | 52 | 0.58 | 0.9 |
| 20 x 12 x 17 | 20 | 12 | 17-5/8 | 49 | 67 | 88 | 1.4 | 1.94 |
| 24 x 12 x 17 | 24 | 12 | 17-5/8 | 55 | 75 | 104 | 1.68 | 2.33 |
| 30 x 12 x 17 | 30 | 12 | 17-5/8 | 65 | 88 | 117 | 2.11 | 2.91 |
| 36 x 12 x 17 | 36 | 12 | 17-5/8 | 73 | 99 | 132 | 2.53 | 3.49 |

* Weights are estimated. Actual capacity depends on angle of material handled and inclination of elevator. Weight is dependent upon metal gauge used. ** Made to order. Available in other sizes.

MF WELDED STEEL

Industrial Welded Metal Elevator Buckets

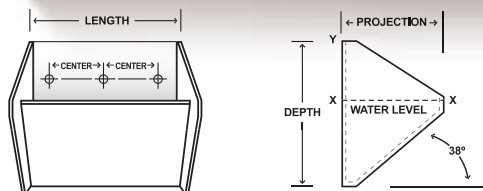

MOUNTING HOLES AND VENTING TO YOUR SPECIFICATIONS

WELDED STEEL

MF CONTINUOUS (MEDIUM FRONT) WELDED STEEL

MF Welded Steel buckets generally utilize a 2-piece construction; a front plate inserts between a press-formed body and is continuously welded to the body on the outside joint. There is approximately a 38° angle from the horizontal to the front plate.

FEATURES & BENEFITS

- Buckets are Continuously Welded
- Typical In Cement, Gypsum or Other Powdery Materials
- Mounted on Chain or Belt
- Venting Available for Clean Filling and Discharge
- Options: Carbon Steel, Aluminum, Stainless Steel, AR Plate, Wear Lips, Hardened Surface and Hard Bead Weld
- Buckets Available In 14ga, 12ga, 10ga, 7ga, 1/4", 5/16", 3/8", 1/2" Steel

MF WELDED STEEL

| BUCKET SIZE, INCHES | | | | WEIGHT, LBS. | | | | CAPACITY, CU. FT.* | |
|---------------------|--------|-------|--------|----------------|----------------|-------------|------------|--------------------|--------------------|
| BUCKET SIZE | Length | Proj. | Depth | 12 Gauge Steel | 10 Gauge Steel | 3/16" Steel | 1/4" Steel | Filled to Line X-X | Filled to Line X-Y |
| 8 x 5 x 7 | 8 | 5 | 7-3/4 | 5.1 | 6.3 | 8.7 | - | 0.040 | 0.070 |
| 9 x 6 x 9 | 9 | 6 | 9-1/4 | 6.7 | 8.6 | 11.9 | - | 0.068 | 0.118 |
| 10 x 5 x 7 | 10 | 5 | 7-3/4 | 5.9 | 7.4 | 10.2 | - | 0.050 | 0.090 |
| 10 x 6 x 9 | 10 | 6 | 9-1/4 | 7.2 | 9.2 | 12.7 | - | 0.075 | 0.130 |
| 10 x 7 x 11 | 10 | 7 | 11-5/8 | 9.3 | 11.9 | 16.5 | - | 0.103 | 0.180 |
| 10 x 8 x 11 | 10 | 8 | 11-5/8 | 9.9 | 12.8 | 17.8 | 23.20 | 0.135 | 0.235 |
| 11 x 6 x 9 | 11 | 6 | 9-1/4 | 7.7 | 9.9 | 13.6 | 18.13 | 0.081 | 0.145 |
| 12 x 6 x 9 | 12 | 6 | 9-1/4 | 8.1 | 10.5 | 14.5 | 19.33 | 0.091 | 0.155 |
| 12 x 7 x 11 | 12 | 7 | 11-5/8 | 10.4 | 13.4 | 18.6 | 24.80 | 0.125 | 0.218 |
| 12 x 8 x 11 | 12 | 8 | 11-5/8 | 11.2 | 14.4 | 20.0 | 26.10 | 0.163 | 0.275 |
| 14 x 7 x 11 | 14 | 7 | 11-5/8 | 11.6 | 14.9 | 20.7 | 27.60 | 0.145 | 0.253 |
| 14 x 8 x 11 | 14 | 8 | 11-5/8 | 12.4 | 16.0 | 22.2 | 29.10 | 0.190 | 0.325 |
| 16 x 8 x 11 | 16 | 8 | 11-5/8 | 13.7 | 17.6 | 24.5 | 32.00 | 0.220 | 0.375 |
| 16 x 12 x 17 | 16 | 12 | 17-5/8 | - | 29.9 | 40.6 | 54.80 | 0.490 | 0.852 |
| 18 x 8 x 11 | 18 | 8 | 11-5/8 | - | 19.2 | 26.7 | 35.00 | 0.250 | 0.420 |
| 18 x 10 x 15 | 18 | 10 | 15 | - | 25.9 | 36.1 | 47.30 | 0.379 | 0.662 |
| 20 x 8 x 11 | 20 | 8 | 11-5/8 | - | 20.8 | 29.0 | 38.00 | 0.270 | 0.470 |
| 20 x 12 x 17 | 20 | 12 | 17-5/8 | - | 34.8 | 48.5 | 63.90 | 0.620 | 1.075 |
| 24 x 10 x 11 | 24 | 10 | 11-5/8 | - | 27.4 | 38.2 | 50.00 | 0.512 | 0.850 |
| 24 x 12 x 17 | 24 | 12 | 17-5/8 | - | 39.8 | 55.4 | 73.10 | 0.745 | 1.295 |

* Weights are estimated. ** Made to order. Available in other sizes.

HF WELDED STEEL

Industrial Welded Metal Elevator Buckets

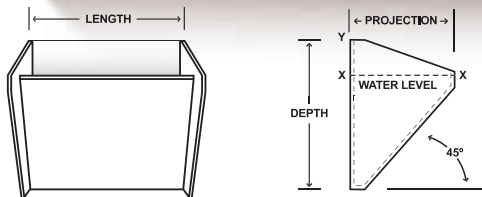
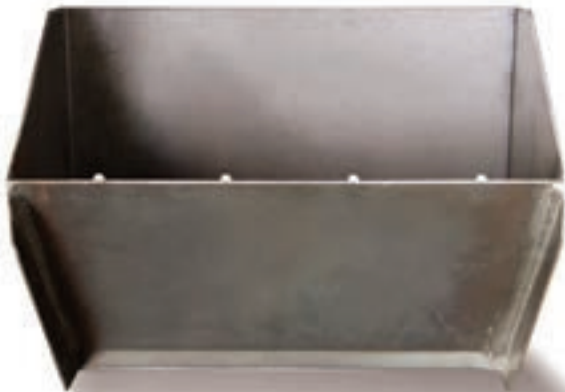

MOUNTING HOLES AND VENTING TO YOUR SPECIFICATIONS

WELDED STEEL

HF CONTINUOUS (HIGH FRONT) WELDED STEEL

HF Welded Steel buckets generally utilize a 2-piece construction; a front plate inserts between a press-formed body and is continuously welded to the body on the outside joint. There is approximately a 45° angle from the horizontal to the front plate.

FEATURES & BENEFITS

- High Front for Increased Capacity
- Reduces Damage to Materials
- Buckets are Continuously Welded
- Mounted on Chain or Belt
- See Punching for Chain and Belt
- Options: Carbon Steel, Aluminum, Stainless Steel, AR Plate, Wear Lips, Hardened Surface and Hard Bead Weld
- Buckets Available In 14ga, 12ga, 10ga, 7ga, 1/4", 5/16", 3/8", 1/2" Steel

HF WELDED STEEL

| BUCKET SIZE, INCHES | | | | WEIGHT, LBS. | | | | CAPACITY, CU. FT.* | |
|---------------------|--------|-------|--------|----------------|----------------|-------------|------------|--------------------|--------------------|
| BUCKET SIZE | Length | Proj. | Depth | 12 Gauge Steel | 10 Gauge Steel | 3/16" Steel | 1/4" Steel | Filled to Line X-X | Filled to Line X-Y |
| 8 x 5 x 7 | 8 | 5 | 7 3/4 | 4.9 | 6.2 | 8.5 | - | 0.052 | 0.080 |
| 10 x 5 x 7 | 10 | 5 | 7 3/4 | 5.7 | 7.3 | 10.0 | - | 0.065 | 0.100 |
| 10 x 6 x 9 | 10 | 6 | 9 1/4 | 7.2 | 9.1 | 12.6 | - | 0.098 | 0.145 |
| 10 x 7 x 11 | 10 | 7 | 11 5/8 | 9.1 | 11.6 | 16.0 | 20.9 | 0.130 | 0.190 |
| 12 x 6 x 9 | 12 | 6 | 9 1/4 | 8.3 | 10.4 | 14.4 | 19.2 | 0.115 | 0.175 |
| 12 x 7 x 11 | 12 | 7 | 11 5/8 | 10.3 | 13.2 | 18.2 | 23.9 | 0.155 | 0.240 |
| 12 x 8 x 11 | 12 | 8 | 11 5/8 | 11.3 | 14.3 | 20.0 | 26.0 | 0.205 | 0.295 |
| 14 x 7 x 11 | 14 | 7 | 11 5/8 | 11.5 | 14.8 | 20.4 | 26.7 | 0.184 | 0.280 |
| 14 x 8 x 11 | 14 | 8 | 11 5/8 | 12.6 | 16.0 | 22.4 | 28.1 | 0.240 | 0.350 |
| 16 x 8 x 11 | 16 | 8 | 11 5/8 | 13.9 | 17.7 | 24.7 | 32.2 | 0.275 | 0.395 |
| 16 x 12 x 17 | 16 | 12 | 17 5/8 | - | 30.3 | 41.9 | 55.0 | 0.635 | 0.900 |
| 18 x 10 x 15 | 18 | 10 | 15 | - | 26.2 | 36.1 | 47.7 | 0.485 | 0.720 |
| 20 x 12 x 17 | 20 | 12 | 17 5/8 | - | 35.1 | 49.1 | 64.6 | 0.800 | 1.150 |
| 24 x 12 x 17 | 24 | 12 | 17 5/8 | - | 40.5 | 56.3 | 74.3 | 0.960 | 1.305 |

* Weights are estimated. ** Made to order. Available in other sizes.

LF WELDED STEEL

Industrial Welded Metal Elevator Buckets



WELDED STEEL

LF CONTINUOUS (LOW FRONT) WELDED STEEL

LF Welded Steel buckets generally utilize a 2-piece construction; a front plate inserts between a press-formed body and is continuously welded to the body on the outside joint. There is approximately a 20° angle from the horizontal to the front plate.

FEATURES & BENEFITS

- Designed for Inclined Elevators
- Mounted on Chain or Belt
- Suitable for Fine or Wet Materials
- Buckets are Continuously Welded
- See Punching for Chain and Belt
- Options: Carbon Steel, Aluminum, Stainless Steel, AR Plate, Wear Lips, Hardened Surface and Hard Bead Weld
- Buckets Available In 14ga, 12ga, 10ga, 7ga, 1/4", 5/16", 3/8", 1/2" Steel

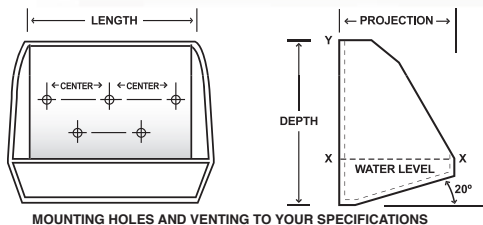

LF WELDED STEEL

| BUCKET SIZE, INCHES | | | | WEIGHT, LBS. | | | | CAPACITY, CU. FT.* | |
|---------------------|--------|-------|--------|----------------|----------------|-------------|------------|--------------------|--------------------|
| BUCKET SIZE | Length | Proj. | Depth | 12 Gauge Steel | 10 Gauge Steel | 3/16" Steel | 1/4" Steel | Filled to Line X-X | Filled to Line X-Y |
| 10 x 6 x 9 | 10 | 6 | 9-1/4 | 6.8 | 8.8 | 12.1 | - | 0.035 | 0.168 |
| 10 x 7 x 11 | 10 | 7 | 11-5/8 | 8.5 | 10.8 | 15.1 | - | 0.050 | 0.242 |
| 12 x 6 x 9 | 12 | 6 | 9-1/4 | 7.8 | 10 | 13.8 | - | 0.042 | 0.201 |
| 12 x 7 x 11 | 12 | 7 | 11-5/8 | 9.6 | 12.3 | 17.1 | 22.8 | 0.060 | 0.302 |
| 12 x 8 x 11 | 12 | 8 | 11-5/8 | 11.2 | 14.4 | 20.1 | 26.8 | 0.075 | 0.347 |
| 14 x 7 x 11 | 14 | 7 | 11-5/8 | 10.7 | 13.7 | 19.1 | 25.5 | 0.070 | 0.345 |
| 16 x 8 x 11 | 16 | 8 | 11-5/8 | 13.6 | 17.4 | 24.3 | 32.4 | 0.101 | 0.463 |
| 16 x 12 x 17 | 16 | 12 | 17-5/8 | - | 29.3 | 40.7 | 53.6 | 0.229 | 1.093 |
| 18 x 10 x 15 | 18 | 10 | 15 | - | 25.4 | 35.0 | 46.5 | 0.183 | 0.494 |
| 20 x 8 x 11 | 20 | 8 | 11-5/8 | - | 20.5 | 28.5 | 38.0 | 0.126 | 0.573 |
| 20 x 12 x 17 | 20 | 12 | 17-5/8 | - | 33.9 | 47.1 | 62.0 | 0.287 | 1.365 |
| 24 x 12 x 17 | 24 | 12 | 17-5/8 | - | 38.5 | 53.5 | 70.5 | 0.346 | 1.643 |

* Weights are estimated. Actual capacity depends on angle of material handled and inclination of elevator. Weight is dependent upon metal gauge used. ** Made to order. Available in other sizes.

ACS WELDED STEEL

Industrial Welded Metal Elevator Buckets



WELDED STEEL

ACS WELDED STEEL

ACS Welded Steel buckets generally utilize a 7-piece construction consisting of end plates, a body, interior braces and bearing plate; the end caps fit on the inside edge of the body and are continuously welded to the body. There is no taper on the sides of the bucket. Bearing plates are tack welded to inside of the body. There is approximately a 50 degree angle from horizontal to the front plate

FEATURES & BENEFITS

- High Front, Saddlebag or Wrap-around Feature Increases Capacity
- Center Braces and Bearing Plates Standard
- Buckets are Continuously Welded
- Suitable for Handling Abrasive Materials Such as Cement, Aggregate, etc.
- Hooded Back Permits Closer Bucket Spacing
- Options: Carbon Steel, Aluminum, Stainless Steel, AR Plate, Wear Lips, Hardened Surface and Hard Bead Weld
- Buckets Available In 14ga, 12ga, 10ga, 7ga, 1/4", 5/16", 3/8", 1/2" Steel
- See Punching (pg 101) for Chain and Belt

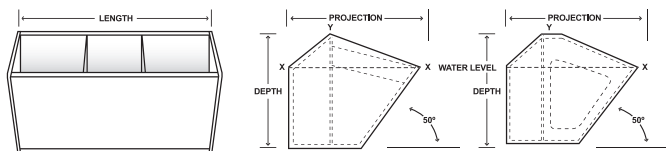

MOUNTING HOLES AND VENTING TO YOUR SPECIFICATIONS

ACS WELDED STEEL

| BUCKET SIZE, INCHES | | | | WEIGHT, LBS | | | CAPACITY, CU. FT.* | |
|---------------------|--------|-------|--------|--------------|---------------|----------|--------------------|--------------------|
| BUCKET SIZE | Length | Proj. | Depth | Steel w/ Lip | Steel w/o Lip | Aluminum | Filled to Line X-X | Filled to Line X-Y |
| 14 x 12 x 11 | 14 | 12 | 11 3/8 | 36 | 32 | 15.3 | 0.37 | 0.53 |
| 16 x 12 x 11 | 16 | 12 | 11 3/8 | 39 | 35 | 17.2 | 0.44 | 0.62 |
| 18 x 12 x 11 | 18 | 12 | 11 3/8 | 42 | 37 | 19.0 | 0.51 | 0.71 |
| 21 x 14 x 13 | 21 | 14 | 13 3/8 | 56 | 51 | 25.3 | 0.78 | 1.08 |
| 24 x 14 x 13 | 24 | 14 | 13 3/8 | 62 | 56 | 27.3 | 0.93 | 1.28 |
| 27 x 15 x 13 | 27 | 15 | 13 3/8 | 72 | 65 | 32.3 | 1.29 | 1.62 |
| 30 x 15 x 13 | 30 | 15 | 13 3/8 | 84 | 77 | 37.3 | 1.47 | 2.84 |

* Weights are estimated. ** Made to order. Available in other sizes.

CUSTOM BUCKETS

Fabricated Steel Bucket Policy



CUSTOM ELEVATOR BUCKETS BUILT TO YOUR SPECIFICATIONS.

Call Us For A Custom Quote.

Providing customized solutions to solve your problems is important to Maxi-Lift. With our large custom metal fabrication shop, we can build products in almost any size, style, or design. Our engineers can work from your drawings, create CAD drawings for approval or copy a sample bucket. We can recommend a combination of materials to help solve wear and performance problems in difficult applications.

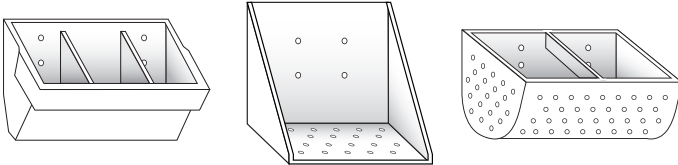

FABRICATED STEEL BUCKET POLICY

General Standards

- Elevator buckets are generally constructed of 14 Gauge, 12 Gauge, 10 Gauge, 7 Gauge, 1/4" or 3/8" materials. Bucket thicknesses may vary slightly in accordance with normal raw materials variances.
- Bucket tolerances for the length, projection and depth are + or - 1/8", and all dimensions on fabricated steel buckets are measured from the outside of the bucket, including wear lips or customizing options.
- Bolt holes are generally created using a plasma burner. There may be a small rounding perimeter of the hole where the plasma burner begins to cut. The holes will be approximately 1/16" larger than the bolt to be installed.
- Buckets are generally MIG (Metal Inert Gas) welded which is standard in the industry.
- Buckets are generally MIG welded continuously on the outside with approximately 1" of weld on the inside top corners of the elevator bucket. Small amounts of weld splatter are possible.
- Wear lips are generally MIG welded continuously on the top and sides and stitch welded on the bottom.
- Metal buckets may have some rust/oxidation due to uncontrollable factors such as condensation.

Customizing Options Available by Special Request

- Wear lips; Hard bead surface weld; Center braces; Vent holes
- Backing plates (outside of the bucket) or Bearing plates (inside of the bucket)
- Continuous welding on the inside of the bucket

Special Notes / Disclaimer

It is critical that all dimensions, angles, and bolt holes be field checked prior to equipment start up to avoid any conflict with existing structures and machinery and to insure proper functioning in the elevator. Please report any errors or discrepancies immediately by calling us toll-free at 800-527-0657 or 972-735-8855. All buckets are custom fabricated and are non-returnable.

MAXI-LIFT



ML
ADDITIONAL
PRODUCTS

ADDITIONAL PRODUCTS

UPGRADE TO THE TOUGHEST ACCESSORIES

- **TITAN & MAXI-SPLICE
BELT FASTENERS**
- **ELEVATOR BOLTS
& ACCESSORIES**
- **HANGER BEARINGS
SCREW CONVEYORS**
- **MIGHTY-MAX
FENCE FEEDERS**
- **UHMW DRAG
FLIGHTS**

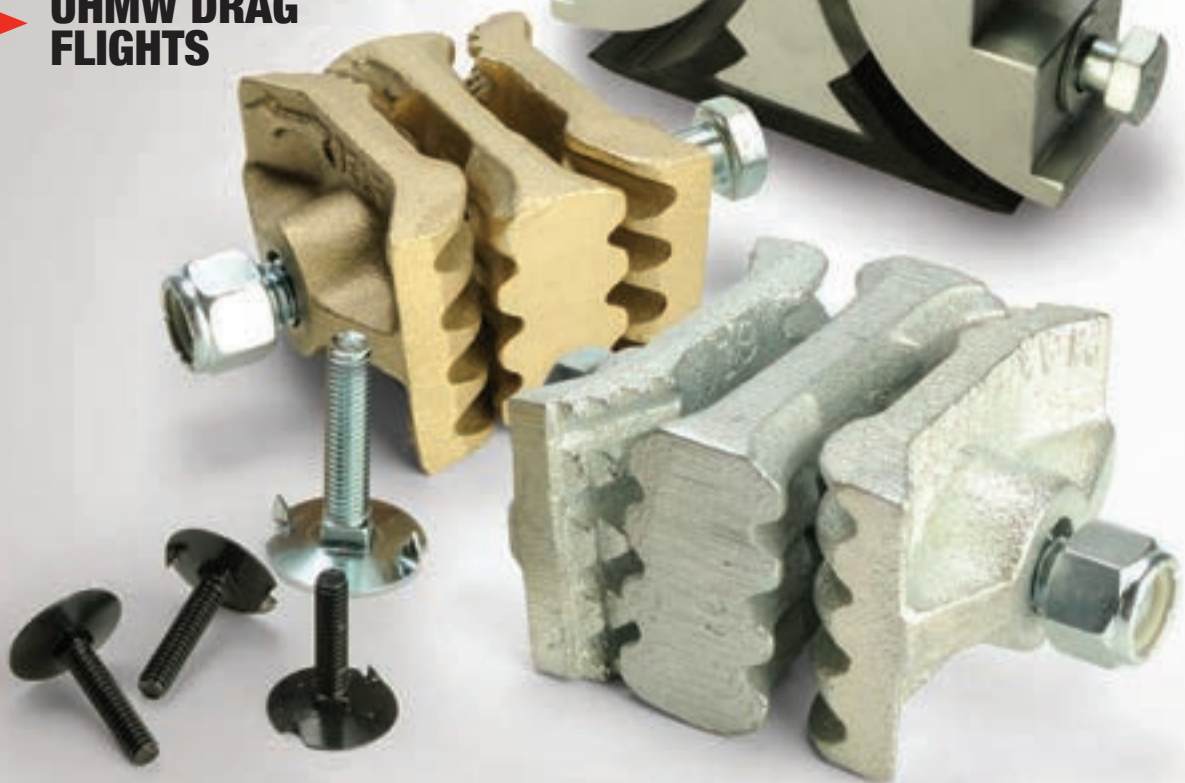

MAXI-LIFT



ELEVATOR BOLTS

Same Day Shipping Available

STANDARD ELEVATOR BOLT

Standard #1 Norway

- Carbon Steel
- Stainless Steel
- Zinc Plated

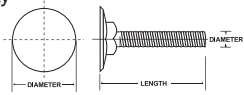

SABRE-TOOTH® ELEVATOR BOLT

Sabre-Tooth®

- Carbon Steel
- Stainless Steel
- Zinc Plated

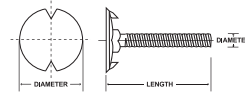

| STANDARD ELEVATOR BOLT | | | |
|------------------------|-------------------------|----------|--------------|
| SIZE, INCHES | WEIGHT / 100 PCS., LBS. | CASE QTY | KEG BULK QTY |
| 1/4 x 3/4 | 2.94 | 1200 | 2000 |
| 1/4 x 1 * | 3.24 | 1200 | 1700 |
| 1/4 x 1-1/4 * | 3.43 | 1200 | 1500 |
| 1/4 x 1-1/2 * | 3.73 | 1200 | 1300 |
| 1/4 x 1-3/4 | 3.98 | 1200 | 1200 |
| 1/4 x 2 | 4.29 | 1200 | 1000 |
| 1/4 x 2-1/4 | 4.88 | 600 | 900 |
| 1/4 x 2-1/2 | 4.92 | 600 | 800 |
| 5/16 x 3/4 | 4.76 | 1200 | 1200 |
| 5/16 x 1 * | 5.05 | 1200 | 1000 |
| 5/16 x 1-1/4 * | 5.55 | 1200 | 900 |
| 5/16 x 1-1/2 * | 6.38 | 600 | 800 |
| 5/16 x 1-3/4 | 6.50 | 600 | 700 |
| 5/16 x 2 * | 7.12 | 600 | 600 |
| 5/16 x 2-1/4 | 7.43 | 600 | 550 |
| 5/16 x 2-1/2 | 7.78 | 600 | 500 |
| 3/8 x 1-1/4 | 6.54 | 600 | 750 |
| 3/8 x 1-1/2 | 7.10 | 600 | 700 |
| 3/8 x 1-3/4 | 7.66 | 600 | 600 |
| 3/8 x 2 * | 8.31 | 600 | 500 |
| 3/8 x 2-1/4 | 9.35 | 600 | 450 |
| 3/8 x 2-1/2 | 9.83 | 600 | 400 |
| 3/8 x 3 | 10.79 | 600 | 300 |

| SABRE-TOOTH ELEVATOR BOLT | | | |
|---------------------------|-------------------------|----------|--------------|
| SIZE, INCHES | WEIGHT / 100 PCS., LBS. | CASE QTY | KEG BULK QTY |
| 1/4 x 3/4 | 2.94 | 1200 | 2000 |
| 1/4 x 1 * | 3.24 | 1200 | 1700 |
| 1/4 x 1-1/4 * | 3.43 | 1200 | 1500 |
| 1/4 x 1-1/2 * | 3.73 | 1200 | 1300 |
| 1/4 x 1-3/4 | 3.98 | 1200 | 1200 |
| 1/4 x 2 * | 4.29 | 1200 | 1000 |
| 1/4 x 2-1/4 | 4.88 | 600 | 900 |
| 1/4 x 2-1/2 | 4.92 | 600 | 800 |
| 5/16 x 3/4 | 4.76 | 1200 | 1200 |
| 5/16 x 1 * | 5.05 | 1200 | 1000 |
| 5/16 x 1-1/4 * | 5.55 | 1200 | 900 |
| 5/16 x 1-1/2 * | 6.38 | 600 | 800 |
| 5/16 x 1-3/4 * | 6.50 | 600 | 700 |
| 5/16 x 2 * | 7.12 | 600 | 600 |
| 5/16 x 2-1/4 | 7.43 | 600 | 550 |
| 5/16 x 2-1/2 | 7.78 | 600 | 500 |
| 3/8 x 1-1/4 | 6.54 | 600 | 750 |
| 3/8 x 1-1/2 | 7.10 | 600 | 700 |
| 3/8 x 1-3/4 | 7.66 | 600 | 600 |
| 3/8 x 2 * | 8.31 | 600 | 500 |
| 3/8 x 2-1/4 | 9.35 | 600 | 450 |
| 3/8 x 2-1/2 | 9.83 | 600 | 400 |
| 3/8 x 3 | 10.79 | 600 | 300 |

RELIANCE ELEVATOR BOLT

#3 Slotted Head

- Carbon Steel
- Zinc Plated

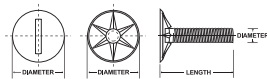

| RELIANCE ELEVATOR BOLT | | | |
|------------------------|-------------------------|----------|--------------|
| SIZE, INCHES | WEIGHT / 100 PCS., LBS. | CASE QTY | KEG BULK QTY |
| 1/4 x 3/4 | 2.7 | 1200 | 2400 |
| 1/4 x 1-1/4 | 3.0 | 1200 | 1800 |
| 1/4 x 1-1/2 | 3.5 | 1200 | 1800 |
| 5/16 x 1-1/4 | 4.9 | 1200 | 1200 |

HEX HEAD BOLT

Hex-Head®

- Zinc Plated
- Grade 5
- Used with Chain Attachments



| HEX-HEAD ELEVATOR BOLT | | | |
|------------------------|-------------------------|----------|--------------|
| SIZE, INCHES | WEIGHT / 100 PCS., LBS. | CASE QTY | KEG BULK QTY |
| 1/2 X 1 | 8.50 | 1200 | 1700 |
| 1/2 x 1-1/4 | 9.45 | 1200 | 1500 |
| 1/2 x 1-1/2 | 10.70 | 1200 | 1300 |
| 3/8 x 1 | 4.15 | 1200 | 1700 |
| 3/8 x 1-1/4 | 4.80 | 1200 | 1500 |
| 3/8 x 1-1/2 | 5.65 | 1200 | 1300 |

Maxi-Lift continually applies metallography tests to our fasteners to ensure the finest quality parts are upheld. ASTM certificates are on file and available upon request.

*Available in 302 Stainless Steel

Maxi-Lift exceeds all industry standards for grade 2 elevator bolts.

WASHERS, NUTS & SPACERS

Call 1-800-527-0657, Visit MAXILIFT.COM for More Info

NUTS

STANDARD HEX



| SIZE, INCHES (ID) | PKG. QTY., PCS. | PKG. WEIGHT, LBS. |
|-------------------|-----------------|-------------------|
| 1/4-20 | 100 | 0.7 |
| 5/16-18 | 100 | 1.1 |
| 3/8-16 | 100 | 1.6 |
| 1/2 | 100 | 3.8 |

Available in zinc and stainless.

STANDARD FLANGE SERRATED LOCK



| SIZE, INCHES (ID) | PKG. QTY., PCS. | PKG. WEIGHT, LBS. |
|-------------------|-----------------|-------------------|
| 1/4-20 | 100 | 0.9 |
| 5/16-18 | 100 | 1.2 |
| 3/8-16 | 100 | 1.8 |

Available in zinc and stainless.

LARGE FLANGE SERRATED LOCK

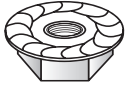

| SIZE, INCHES (ID) | PKG. QTY., PCS. | PKG. WEIGHT, LBS. |
|-------------------|-----------------|-------------------|
| 1/4-20 | 100 | 1.2 |
| 5/16-18 | 100 | 2.3 |
| 3/8-16 | 100 | 2.8 |

Available in zinc.

NYLON INSERT LOCK

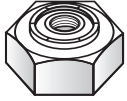

| SIZE, INCHES (ID) | PKG. QTY., PCS. | PKG. WEIGHT, LBS. |
|-------------------|-----------------|-------------------|
| 1/4-20 | 100 | 0.8 |
| 5/16-18 | 100 | 1.1 |
| 3/8-16 | 100 | 2.8 |

Available in zinc and stainless.

DIRECTIONS FOR PROPER ELEVATOR BOLT TORQUE ON BELT

1. To tighten the nuts, use a torque wrench that will "click" out when proper setting is reached.
2. Run the elevator with the buckets empty for 4 hours.
3. Check all bolts to insure that the proper torque is maintained.

RECOMMENDED TORQUE FOR ELEVATOR BOLTS

| SHANK DIAMETER | STEEL | | | STAINLESS | | |
|----------------|------------|----------|------------|------------|----------|------------|
| | IN. / LBS. | KGM / M. | FT. / LBS. | IN. / LBS. | KGM / M. | FT. / LBS. |
| 1/4" | 50 | 0.57 | 4 | 86 | .99 | 7.16 |
| 5/16" | 96 | 1.10 | 8 | 177 | 2.04 | 14.75 |
| 3/8" | 180 | 2.07 | 15 | - | - | - |

**Do not exceed recommended torque values, as this could strip the bolts.

RECOMMENDED BUCKET INSTALLATION

A locking device should be used on all elevator bucket installations.

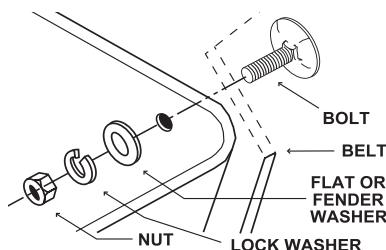

WASHERS AND SPACERS

FLAT

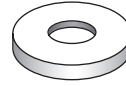

Available in zinc and stainless.

| SIZE, INCHES (ID) | PKG. QTY., PCS. | PKG. WEIGHT, LBS. | O.D. INCHES |
|-------------------|-----------------|-------------------|-------------|
| 1/4 | 100 | 1.3 | 1 |
| 5/16 | 100 | 2.0 | 7/8 |
| 3/8 | 100 | 3.0 | 1 |
| 1/2 | 100 | 3.8 | 1-3/8 |

SPLIT RING LOCK



Available in zinc and stainless.

| SIZE, INCHES (ID) | PKG. QTY., PCS. | PKG. WEIGHT, LBS. | O.D. INCHES |
|-------------------|-----------------|-------------------|-------------|
| 1/4 | 100 | 0.2 | 1-1/4 |
| 5/16 | 100 | 0.4 | 7/8 |
| 3/8 | 100 | 0.6 | 1 |
| 1/2 | 100 | 1.4 | 1-3/8 |

FENDER*



Available in zinc and stainless.

| SIZE, INCHES (ID) | PKG. QTY., PCS. | PKG. WEIGHT, LBS. | O.D. INCHES |
|-------------------|-----------------|-------------------|-------------|
| 1/4 | 100 | 1.3 | 1 |
| Large 1/4 | 100 | 1.3 | 1-1/4 |
| 5/16 | 100 | 2.0 | 7/8 |
| Large 5/16 | 100 | 3.0 | 1-1/2 |
| 3/8 | 100 | 3.0 | 1 |
| 1/2 | 100 | 3.8 | 1-3/8 |

LEATHER

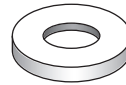

| SIZE, INCHES (ID) | PKG. QTY., PCS. | PKG. WEIGHT, LBS. | O.D. INCHES |
|-------------------|-----------------|-------------------|-------------|
| 1/4 | 100 | 0.3 | - |
| 5/16 | 100 | 0.3 | - |
| 3/8 | 100 | 0.3 | - |

POLY SPACERS

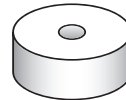

Available in 1/4" and 1/2" thick.

| SIZE, INCHES (ID) | PKG. QTY., PCS. | PKG. WEIGHT, LBS. | O.D. INCHES |
|-------------------|-----------------|-------------------|-------------|
| 1/4 | 100 | 2.0 | - |
| 5/16 | 100 | 1.8 | - |

NEOPRENE

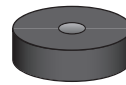

Available in 1/4" thick.

| SIZE, INCHES (ID) | PKG. QTY., PCS. | PKG. WEIGHT, LBS. | O.D. INCHES |
|-------------------|-----------------|-------------------|-------------|
| 1/4 | 100 | 1.1 | - |
| 5/16 | 100 | 1.1 | - |
| 3/8 | 100 | 1.1 | - |

*When installing urethane buckets always use Fender Washers.

TITAN® BELT SPLICE

The Ultimate Belt Splice

THE MAXI-LIFT TITAN

ENGINEERED BELT SPLICE

DESIGNED FOR ELEVATOR BELTS RATED HIGHER THAN 800 PIW

PERFECT FOR HIGH CAPACITY, TERMINAL AND EXPORT BUCKET ELEVATORS, PROCESSING PLANTS AND RIVER FACILITIES

LARGE SURFACE AREA AND RADIUS GIVES THE TITAN TREMENDOUS SURFACE AREA TO GRIP BELTING AND PROVIDE SUPERIOR HOLDING STRENGTH

FEATURES & BENEFITS

- Engineered to Each Application
- Large Radius for Heavy Belts
- High Grade Aluminum Construction
- Non Sparking / Corrosion Resistant
- Three Part Design Features
EPDM Rubber Wedge
- Belts Rated at Higher Than 800 PIW

*Cannot be used on belts at 800 PIW or lower.



TITAN® BELT SPLICE

Call 1-800-527-0657, Visit MAXILIFT.COM for More Info

THE MAXI-LIFT TITAN: TITAN SPLICE EQUALS TITANIC PERFORMANCE

Introducing the Maxi-Lift **TITAN**, the Ultimate Elevator Belt Splice. **TITAN**'s innovative design, maximum duty solid aluminum construction and superior quality materials make other splices obsolete for heavy elevator belts. The **TITAN** sets a new standard for splice performance. The **TITAN** is constructed of a central aluminum vice-grip section which is bracketed by two exterior solid aluminum clamps. Utilizing clamping force, and friction to secure its load, the belt ends are bent through a 75 mm radius to a 90° angle. The central wedge is equipped with a rubber backing on the pulley side to prevent belt wear due to pressure and friction generated in operation.

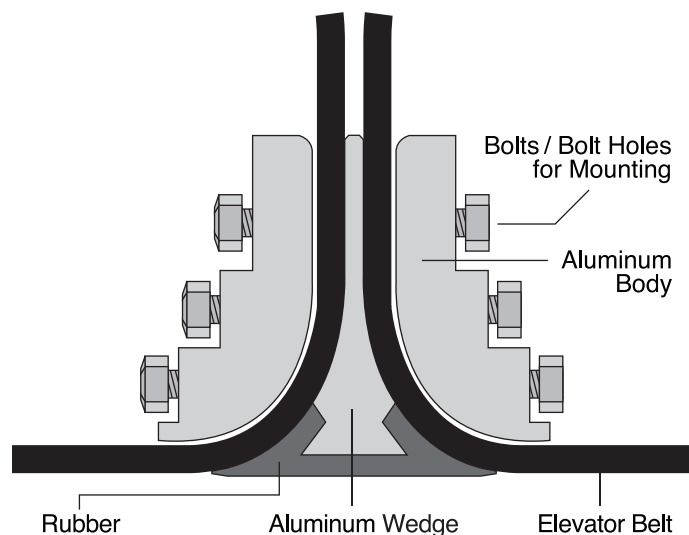
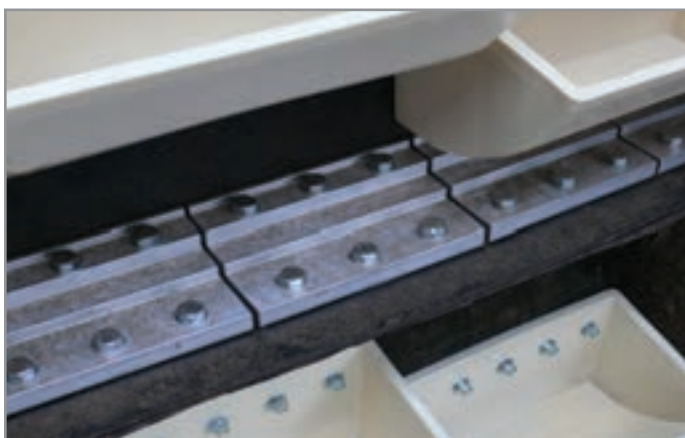

TECHNICAL INFO

Rubberized wedge section suitable for use up to 266°F/ 130°C. For temperatures exceeding 266°F/ 130°C the rubber segment is replaced by an all aluminum wedge.

Failure to properly select or install any belt splice can result in splice failure and cause equipment and property failure which may also result in bodily injury or death. Proper procedures for installation **must be strictly followed**. SEE FULL DISCLAIMER ON WWW.MAXI-LIFT.COM

MAXI-SPLICE® BELT SPLICE

For More Information, Call 1-800-527-0657

MAXI-SPLICE® BELT FASTENING SYSTEMS



MAXI-SPLICE AB (New Enhanced Design!)

- New 9/16" Diameter Grade 5 Bolt
- Non-Ferrous Metal of Very High Tensile Strength
- Usable On Belts of up to 800 Piw Tensile
- Non-Sparking, Non-Corroding and Non-Rusting
- Bronze Color
- Weight: 2.9 Lbs. Each



MAXI-SPLICE CI

- Ferrous Metal of Moderately High Tensile Strength
- Usable on Belts of Up to 600 PIW Tensile
- Silver Color
- Weight: 2.6 Lbs. Each



DESCRIPTION

- The MAXI-SPLICE is a mechanical clamping device with a simple 3-piece construction. The design is for use on PVC and rubber belting.
- Use 4" long bolts for belts up to 1/4" thick.
- Use 4 1/2" long bolts for belts between 1/4" and 1/2" thick.
- Use 5" long bolts for belts between 1/2" and 5/8" thick.
- Maximum operating temperatures: AB: 500°F, CI: 600°F.
- Each splice set accommodates two inches of belt width.
- It is tested and approved by leading manufacturers of PVC and rubber belting.

INSTALLATION

1. First ensure the belt ends are square and even. If using the splice template tape, apply the tape to mark the punching. Be sure to apply the tape squarely on the belt ends; then proceed to Step 4. If you are not using the tape, go to Step 2.
2. Draw a line approximately 4-1/4" from the belt end to use as the center line for hole punching. Proper installation for even width belts will begin just inside the belt edge. Odd belt widths require installation 1/2" from the belt edge.
3. Use the Maxi-Splice as a template to mark the hole locations for punching. After marking the first hole, move over 2" and mark each consecutive hole.
4. Punch both belt ends for the appropriate bolt size
5. The two end plates and center plate are used for firm belt gripping. The end plates have two gripping areas - the slotted gripping area is mounted toward the face of the belt and is followed by a series of gripping teeth. These teeth are always mounted toward the tail of the belt. The center plate is symmetrical and cannot be improperly installed.
6. **IMPORTANT:** We have supplied a Grade 5 bolt and nylon locking nut. The bolts must be torqued for Maxi-Splice to effectively clamp. The torque requirement is 75 foot pounds for belts up to and including 600 PIW - belts greater than 600 PIW tensile require 100 foot pounds of torque.
7. Run the belt for thirty minutes; stop the leg and re-torque the bolts.
8. Regular inspection is required to maintain splice integrity.
9. When reinstalling the Maxi-Splice always use new Nylock nuts.

INSTALLATION PHOTOS

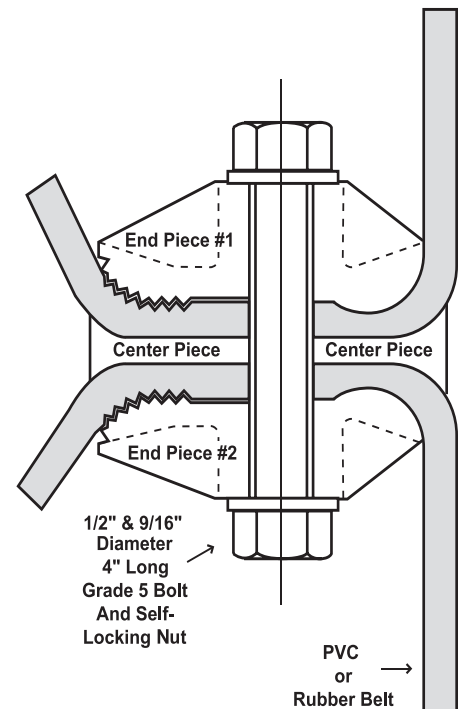

MAXI-SPLICE® BELT SPLICE

For More Information, Visit WWW.MAXILIFT.COM

TEMPLATE TAPE - FREE

- Peel and stick directly on belt
- Improves belt-punching convenience
- Marks hole locations for odd or even width belts
- Clearly marked in white and red lettering
- Included with every splice order

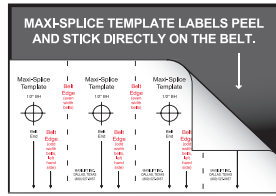

MAXI-SPLICE® BELT FASTENING SYSTEMS

POWER PUNCH

- Made with durable heat treated carbon-steel
- Reinforced blade easily cuts 1/2" and 9/16" diameter holes
- Impact adapter available when necessary
- Use with a hand-held mallet, impact wrench, or drill
- Always wear eye protection



ADDITIONAL INFORMATION

Maxi-Splice is a patented mechanical splice device for use on most elevator belts (PVC and rubber). To accommodate various PIW belt tension ratings, Maxi-splice is available in two different metals. The Maxi-Splice "CI" is ferrous metal of moderately high tensile strength and can be used on belts up to 600 PIW. The Maxi-Splice "AB" is a non-ferrous metal of very high tensile and shear strength. The Maxi-Splice "AB" does not rust or corrode and is non-sparking. Maxi-Splice "CI" and Maxi-Splice "AB" are identical in appearance with the exception that the "AB" Maxi-Splice exhibits a bronze color. The CI and AB should never be intermixed, as reduction in clamping power may occur.

Each splice unit is made of three pieces. Two are identical outside plates; the third is a center plate with an elongated center hole. The outside plates and the center plate are "mating" parts with peaks and valleys opposite of each other for firm gripping. The outside plates have two different gripping areas. The ribbed gripping area is mounted towards the face of the belt. The opposite end has a series of both longitudinal and axial "teeth." The teeth are always mounted at the tail of the belt; they too have opposite peaks and valleys in the center plate for firm holding. The center plate is symmetrical and cannot be improperly installed around its elongated center hole.

The splice functions by using the tension supplied by the belting. This tension on the belt ends pulls the outer plates apart, and forces gripping pressure towards the teeth on the splice unit. The greater the belt tension, the more pressure is exerted on the gripping teeth at the forward end of the splice. The splice is held together by a grade 5 bolt. The length of the bolt varies depending on belt thickness. If for any reason bolt replacement ever occurs, a grade 5 or better bolt must be used, with a nylon insert locking nut.

The clamping, holding force of the splice can only be facilitated after the grade 5 bolt is torqued during installation. Minimum torque of 75ft. lbs is required on the Maxi-Splice "CI." A 100ft. lbs torque minimum is required on the Maxi-Splice "AB." A torque wrench is required for proper installation. After installation is complete the belt must be run under load, for 30 minutes, then, each bolt must be re-torqued. Regular inspection is required to maintain splice integrity.

Each Maxi-Splice set will connect approximately 2" of belt width. On a 36" wide belt for example, 18 Maxi-Splice sets are required. See the Maxi-Splice installation sheet for proper use of the template tape or for placement and belt punching suggestions. The Maxi-Splice has been tested and approved by leading manufacturers of both PVC and rubber elevator belts.

WARNING: DO NOT USE MAXI-SPLICE ON MANLIFTS!

- Maxi-Lift, Inc. and Dura-Buket, Co neither solicits nor recommends the use of the Maxi-Splice CI or AB belt clamp in splicing man lift belts. The Maxi-Splice was not designed for or tested for this purpose. Any installation of the Maxi-Splice in this application may cause serious harm or even death. Do not use on steel cable belts.
- Do not re-use nylock nuts on Maxi-Splices. When reinstalling splices, please use new nylock nuts. Replacements are available from Maxi-Lift.
- The AB and CI Maxi-Splice is not recommended for use on a standard wing pulley. It may cause premature wear on the backside of the belt around the splice. It may also create noise in the boot section of the bucket elevator as the metal splice may contact the wings of the pulley. The AB and CI Maxi-Splice may be used on a spiral wing pulley.

HANGER BEARINGS

For Screw Conveyors

SCREW CONVEYOR HANGER BEARINGS

STYLE "A" BEARING: STYLE 226

Two-piece double flange bearing for screw conveyor hanger with formed strap.
This hanger bearing is interchangeable with the following styles: 20A, 20B, 26B, 28A, 30, 50, 220, 226 228 and 326.

| STYLE A: DIMENSIONS | | | | |
|---------------------|--------|---------|---------|--------|
| A | B | C | D | E |
| 1-1/2 | 2-3/16 | 2-1/2 | 1-7/8 | 1-9/16 |
| 2 | 2-3/4 | 3-1/8 | 1-15/16 | 1-9/16 |
| 2-7/16 | 3-1/4 | 3-11/16 | 2-15/16 | 2-3/8 |
| 3 | 4 | 4-3/8 | 2-15/16 | 2-1/4 |
| 3-7/16 | 4-3/4 | 5 | 3-3/16 | 3-1/16 |

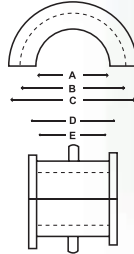



*Tolerances: + 1/16" / - 0"

Other sizes available on request. Hanger strap not included.



AVAILABLE MATERIALS

| | PLASTECH | WEARITE* | UHMW | WOOD |
|------------------------------------|---|---|---|---|
| MAXI-LIFT HANGER BEARINGS |  |  |  |  |
| MATERIAL | Engineered Nylon Resin | Engineered Nylon Resin | Polyethylene | Maple |
| GRADE | Food Grade, FDA | Industrial Grade | Food Grade, FDA | Industrial Grade |
| METHOD OF MANUFACTURE | Injection Molded | Injection Molded | Machined Or Molded | Machined |
| TEMPERATURE OPERATING RANGE | -60°F To +300°F | -60°F To +300°F | -22°F To +180°F | -50°F To +160°F |
| LUBRICANT | Built-In Lubricant | Built-In Lubricant* | Natural | Oil Impregnated |
| COLOR | Tan | Black | White | Brown |

*Wearite bearings available drilled and tapped for lubing or purging pipes at additional cost.

STYLE "B" BEARING: STYLE 18B

Cap type half bearing for screw conveyor hanger with U-bolt construction. Hanger Styles 17, 18, 18A, 18B, 19B and 40.
Available in wood and UHMW.

| STYLE B: DIMENSIONS | | | | |
|---------------------|--------|---------|---------|-------|
| A | B | C | D | E |
| 3 | 3-7/8 | 4-13/16 | 2-7/8 | 13/16 |
| 3-7/16 | 4-7/16 | 5-3/8 | 3-13/16 | 7/8 |

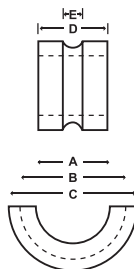

*Tolerances: + 1/16" / - 0"

Other sizes available on request.
Hanger strap not included.



UHMW SHEET MATERIAL

For Liners or Machined Parts

UHMW SHEET MATERIAL SPECIFICATIONS

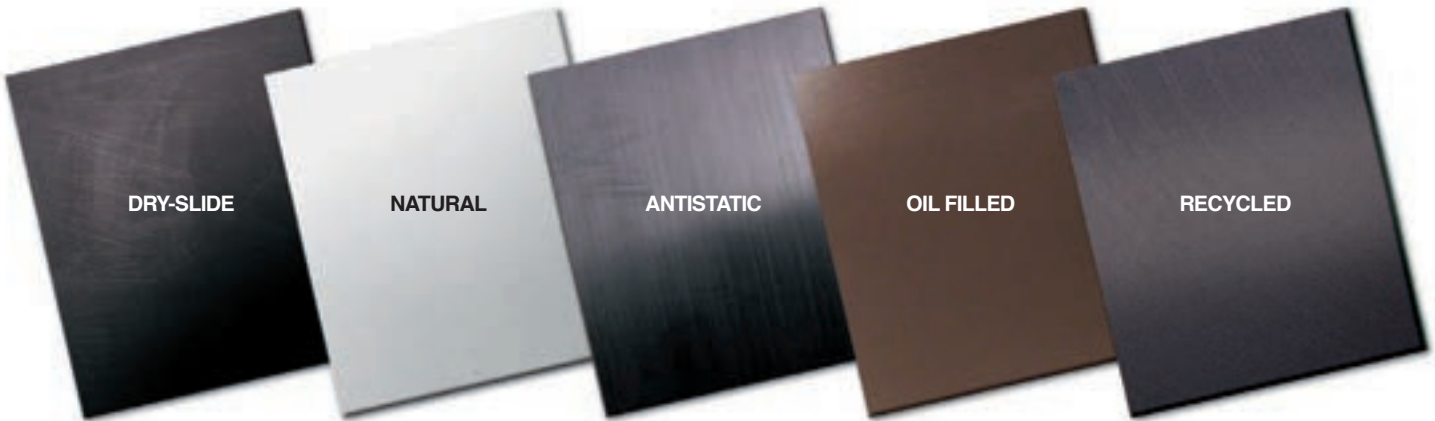

NATURAL UHMW

White in color. This UHMW sheet meets FDA/USDA and 3-A dairy guidelines. It is an excellent high wear material.

REPROCESSED OR RECYCLED UHMW

Black in color. This sheet is a blend of virgin and regenerated UHMW polymers that maintain an acceptable combination of properties for less demanding applications. This sheet is not FDA approved.

ANTISTATIC UHMW

Black in color. This UHMW sheet protects parts sensitive to build up of static electricity. It permits partial transmission of electrical charge, thus dissipating static build-up. It provides a slick surface.

DRY-SLIDE UHMW

This UHMW sheet is modified with special dry additives for enhanced coefficient of friction and antistatic properties. This is an effective sheet in dusty environments where components need lubrication without build-up.

OIL FILLED UHMW

This UHMW sheet meets FDA/USDA guidelines for food and pharmaceutical handling. It has an oil additive to lubricate mating surfaces. This Oil Filled UHMW is used in closed loop continuous chain applications. It is not recommended for dusty applications.

PRIME UHMW POLYETHYLENE SHEETING (PER SHEET) 48" X 120"

| GAUGE, INCHES | WEIGHT, LBS./ SHEET | TOLERANCE |
|---------------|---------------------|-----------|
| 1/16" | 13 | +/- 10% |
| 1/8" | 25 | +/- 10% |
| 3/16" | 38 | +/- 10% |
| 1/4" | 50 | +/- 10% |
| 3/8" | 75 | +/- 10% |
| 1/2" | 100 | +/- 10% |
| 5/8" | 125 | +/- 10% |
| 3/4" | 150 | +/- 10% |
| 1" | 200 | +/- 10% |
| 1-1/4" | 250 | +/- 10% |
| 1-1/2" | 300 | +/- 10% |
| 1-3/4" | 350 | +/- 10% |
| 2" | 400 | +/- 10% |
| 2-1/2" | 500 | +/- 10% |
| 3" | 600 | +/- 10% |
| 3-1/2" | 700 | +/- 10% |
| 4" | 800 | +/- 10% |

Temperature Range: Continuous -22° F to +180° F

DRAG CONVEYOR FLIGHTS

Common Sizes & Styles In Stock for Immediate Delivery

UHMW DRAG CONVEYOR FLIGHTS

Maxi-Lift manufactures and stocks replacement UHMW drag conveyor flights to fit popular drag conveyor designs. We can custom make flights based on your drawing or sample, using our CAD based software and manufacturing process. You get UHMW flights made with precision that perform every time.

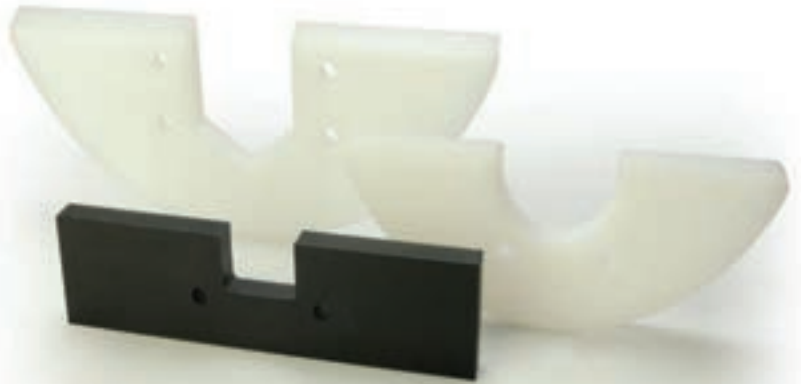
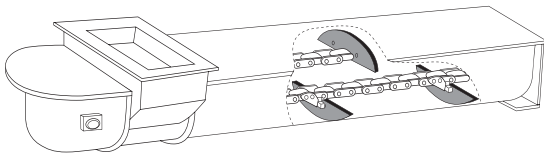

DRAG CONVEYOR FLIGHTS: AVAILABLE MODELS

| DRAG CONVEYOR FLIGHTS | | | | | | |
|--------------------------------------|-------------------------------|-----------------------------------|-------------------------------|-----------------------|-------------------|---------|
| SIZE, INCHES (LENGTH & THICKNESS) | SCREW CONVEYOR SUPERFLO | ESSMUELLER COMPANY PEERLESS | THOMAS CONVEYOR FLI-CON | JEFFERY MULTI-FLOW | EHR SAM DRACON | ENMASSE |
| 6 x 1/4 | X | - | - | X | - | X |
| 6 x 3/8 | X | - | X | - | X | X |
| 9 x 1/4 | X | - | - | X | - | X |
| 9 x 3/8 | X | X | - | X | X | X |
| 9 x 1/2 | X | X | X | - | - | X |
| 10 x 3/8 | - | - | - | - | - | X |
| 10 x 1/2 | - | - | - | - | - | X |
| 12 x 3/8 | X | X | - | X | X | X |
| 12 x 1/2 | X | X | X | - | - | X |
| 14 x 3/8 | X | X | - | X | X | X |
| 14 x 1/2 | X | X | - | - | - | X |
| 16 x 3/8 | X | X | - | X | - | X |
| 16 x 1/2 | X | X | X | - | - | X |
| 18 x 3/8 | X | - | - | X | - | X |
| 18 x 1/2 | X | X | - | - | - | X |
| 20 x 1/2 | - | X | - | X | - | X |
| 20 x 5/8 | - | - | X | - | - | X |
| 24 x 1/2 | - | X | - | X | - | X |
| 24 x 5/8 | - | - | X | - | - | X |

* Photos of drag conveyor flights are representations of flights. Actual flights may vary in size and shape.

SPECIFICATIONS

MATERIAL: Virgin Ultra High Molecular Weight (UHMW) polyethylene is white. Reprocessed UHMW polyethylene is black. Static reduced UHMW is black. UHMW has a thickness tolerance of +/- 10%.

STYLE: Drag conveyor flights are fabricated to original manufacturer's design. Cut edges are square unless otherwise noted.

CUSTOM FLIGHTS: Non-standard flights can be custom fabricated to your specifications. Please send print or sample for fabrication of flight.

TEMPERATURE: -22° F to +180° F or -51° C to +82° C

ORDERING: Before ordering, please note manufacturer design, number of flights, size and thickness. If a custom drag conveyor flight is required, please have sample or drawing available.

DRAG CONVEYOR FLIGHTS

Complete and Fax for a Custom Quote

ROUND BOTTOM FLIGHTS

Round bottom flights are standardized according to conveyor manufacturer. Most common sizes and styles are stocked for immediate shipment. Custom round bottom flights can be made and shipped quickly.

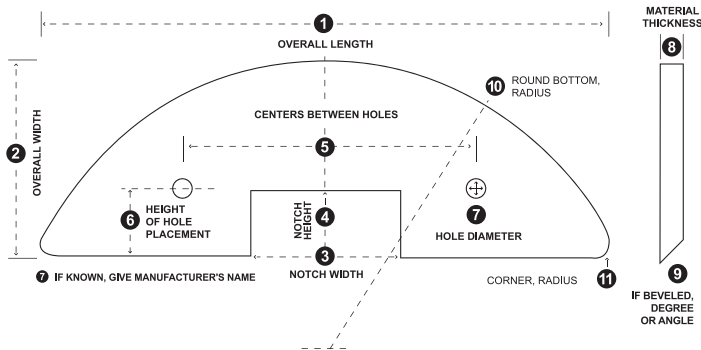

EN MASSE FLIGHTS

The en masse flight is the most customized flight design. It can vary in height, length and thickness. There are few standardized en masse sizes.

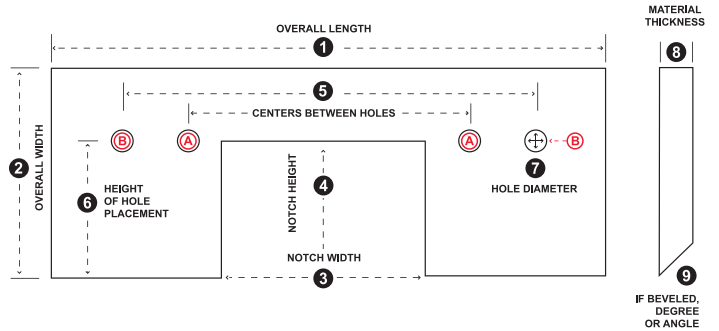

CUSTOM DRAG FLIGHT QUOTE REQUEST Please fill in the following information and fax back to Maxi-Lift at (972)735-8896.

USER INFORMATION (Primary Contact)

Name _____ Title _____

Company Name _____

Shipping Address _____

City _____ State _____ Zip _____

Phone _____ Fax _____

Email Address _____

Website _____

6 Height of Hole Placement: _____

7 Hole Diameter: _____

8 Material Thickness: _____

9 If Beveled, Degree or Angle: _____

10 Round Bottom Radius: _____

12 Corner Radius: _____

11 Material Type: (Please Check One)

Virgin UHMW: Nylon: Reprocessed UHMW:

Other: _____

DRAG FLIGHT SPECIFICATIONS

ROUND BOTTOM EN MASSE (Please Check One)

1 Overall Length: _____ 2 Overall Width: _____

3 Notch Width: _____ 4 Notch Height: _____

5 Centers Between Holes - Round Bottom: _____

Centers Between Holes - En Masse: (A) _____ (B) _____

(A) _____ (B) _____

13 Manufacturer Name (if known): _____

14 Quantity Needed: _____

15 Customer Part #: _____

Additional Info: _____

MIGHTY-MAX® FENCE FEEDERS

Tough, Portable Plastic Feeders

MIGHTY-MAX® FENCE FEEDERS

Portable, easy to install, and tough, the **MIGHTY-MAX** fence feeder is the most versatile livestock feeder on the market. Quickly and securely snaps onto any chain-link or wire fencing. Built with two spring link clips installed on a super tough HDPE feeder, it can take the toughest animal and weather abuse. This is the ideal feeder for show pens, trailers and fenced areas. Keeps feed up off the ground and reduces waste.



STYLE FFSS



STYLE FFCC



STYLE FFHD

FEATURES & BENEFITS

- Made of prime virgin HDPE
- Thick, heavy duty walls
- Extended feeder life
- Tough enough to withstand the harshest animal and weather abuse
- Drilled for and attached with 8mm Spring Link Clips (right)
- Stocked / available in ten (10) standard sizes



| ITEM CODE | FEEDER SIZE, INCHES | | | | | PUNCHING, IN. | | | | CAP. | WEIGHT, LBS. | | QUANTITIES | |
|------------------------|---------------------|--------|---------|-------|-------|---------------|------------|-----------|----------|--------|---------------|---------------|------------|----------|
| | Color | Size | Length | Proj. | Depth | Hole Centers | # Of Holes | Bolt Size | Top Down | Quarts | Lbs. Per Each | Lbs. Per Skid | Carton Qty | Skid Qty |
| FFSS 09 x 5 P W | White | 9 x 5 | 9-3/8 | 5-1/4 | 4-7/8 | 3-1/4 | 3 | 1/4 | 1 | 1.0 | 1.00 | 420 | 24 | 384 |
| FFSS 16 x 7 P W | White | 16 x 7 | 16-3/8 | 7-3/8 | 7-1/4 | 14-3/4 | 2 | 3/8 | 9/16 | 4.5 | 2.75 | 638 | 12 | 192 |
| FFHD 10 x 7 P B | Black | 10 x 7 | 10-1/2 | 7-3/4 | 7-1/8 | 8-3/4 | 2 | 3/8 | 9/16 | 3.5 | 2.75 | 784 | 16 | 256 |
| FFHD 14 x 7 P B | Black | 14 x 7 | 14-1/2 | 7-3/4 | 7-1/8 | 12-3/4 | 2 | 3/8 | 9/16 | 5.0 | 3.35 | 848 | 7 | 112 |
| FFHD 18 x 8 P B | Black | 18 x 8 | 18-1/2 | 8-3/4 | 8 | 16-1/4 | 2 | 3/8 | 9/16 | 9.0 | 5.10 | 810 | 7 | 112 |
| FFCC 09 x 5 P G | Gray | 9 x 5 | 9-1/2 | 5-1/2 | 5 | 7-1/2 | 2 | 3/8 | 9/16 | 1.5 | 1.20 | 498 | 28 | 448 |
| FFCC 11 x 6 P G | Gray | 11 x 6 | 11-9/16 | 6-5/8 | 6 | 9-9/16 | 2 | 3/8 | 9/16 | 3.0 | 1.90 | 573 | 13 | 208 |
| FFCC 14 x 7 P G | Gray | 14 x 7 | 14-9/16 | 7-7/8 | 7 | 12-3/4 | 2 | 3/8 | 9/16 | 5.0 | 3.50 | 848 | 7 | 112 |
| FFCC 18 x 8 P G | Gray | 18 x 8 | 18-9/16 | 8-7/8 | 8-1/4 | 16-1/4 | 2 | 3/8 | 9/16 | 9.0 | 5.10 | 810 | 5 | 80 |
| FFCC 20 x 8 P G | Gray | 20 x 8 | 20-9/16 | 8-7/8 | 8-1/4 | 18-9/16 | 2 | 3/8 | 9/16 | 10.0 | 6.10 | 792 | 5 | 80 |



MAXI-LIFT



ENGINEERING

BUCKET ENGINEERING

- **CAPACITIES**
ELEVATOR BUCKETS
& ELEVATORS
- **SPEED CHARTS**
AGRICULTURAL &
INDUSTRIAL
- **PUNCHING**
BELT & CHAINS
- **BULK MATERIAL
HANDLING**



MAXI-LIFT



CALCULATING CAPACITY

For More Information, Call 1-800-527-0657

CALCULATING BUCKET ELEVATOR CAPACITY

| CAPACITY of the Bucket at Water Level (Cubic Inches) | NUMBER OF BUCKETS Per Foot (12 ÷ Spacing In Inches) | NUMBER OF ROWS of Buckets on the Belt | SPEED of the Belt or Chain FPM (Feet Per Minute) | CUBIC IN. PER HOUR See Below for Conversion |
|--|---|--|--|---|
| _____ | X _____ | X _____ | X _____ | X $\frac{60}{\text{MINUTES}}$ = _____ |

For engineering purposes, Maxi-Lift recommends using water level capacity as the basis for calculation. Actual bucket fill will vary depending on the product and operational conditions.

- STEP 1** Multiply the CAPACITY of the bucket times the NUMBER OF BUCKETS per foot (12 divided by spacing) times the NUMBER OF ROWS of buckets. This will give the capacity in cubic inches of each running foot of the belt or chain.
- STEP 2** Multiply the answer times the SPEED of the belt or chain in FPM for the capacity discharged per minute.
- STEP 3** Then multiply by 60 minutes to get cubic inches per hour.

CONVERT CUBIC INCHES PER HOUR AS FOLLOWS:

- BUSHELs:** Divide by 2,150 to convert to bushels.
- CUBIC FEET:** Divide by 1,728 to convert to cubic feet.
- SHORT TONS:** Multiply cubic feet capacity times weight of product per cubic foot and divide by 2,000.
- METRIC TONS:** Multiply cubic feet capacity times weight of product per cubic foot and divide by 2,204.62.

FEET PER MINUTE

| π | HEAD PULLEY DIAMETER (IN.) | RPM | IN. / FT. | FT. / MIN. |
|----------|-------------------------------|---------|-----------|------------|
| (3.1416) | X _____ | X _____ | ÷ 12 | = _____ |

BUSHELs PER HOUR

| CU. IN. / HOUR | CU. IN. / BUSHEL | BPH |
|----------------|------------------|---------|
| _____ | ÷ 2,150 | = _____ |

CUBIC FEET PER HOUR

| CU. IN. / HOUR | CU. IN. / CU. FT. | CU. FT. / HOUR |
|----------------|-------------------|----------------|
| _____ | ÷ 1,728 | = _____ |

SHORT TONS PER HOUR

First determine cubic ft / hr. at water level using above formula then proceed as follows

| CU. FT. / HOUR | WEIGHT OF PRODUCT / CU. FT. | LBS. / HOUR | LBS. / TON | TONS / HOUR |
|----------------|--------------------------------|-------------|------------|-------------|
| _____ | X _____ | = _____ | ÷ 2,000 | = _____ |

METRIC TONS PER HOUR

First determine cubic ft/hr. at water level using above formula then proceed as follows

| CU. FT. / HOUR | WEIGHT OF PRODUCT / CU. FT. | LBS. / HOUR | LBS. / METRIC TON | METRIC TONS / HOUR |
|----------------|--------------------------------|-------------|-------------------|--------------------|
| _____ | X _____ | = _____ | ÷ 2204.62 | = _____ |

CALCULATING HORSEPOWER

The formula below will result in the theoretical horsepower necessary. It is recommended that an additional 25% minimum be added for drive losses and up to 15% for elevator friction and cup digging through the boot.

$$\text{HP (at head Shaft)} = \frac{W \times H}{33,000} \quad W = \frac{\text{LBS. / HOUR}}{60 \text{ MINUTES}} \quad H = \text{Vertical Lift in Feet}$$

SPEED CHARTS: HIGH SPEED ELEVATOR BUCKETS

TIGER-TUFF®, TIGER-CC®, HD-MAX®, CC-MAX®

AGRICULTURAL ELEVATOR BUCKET SPEED CHART

Recommended Minimum and Optimum Pulley Speeds for the following Maxi-Lift Agricultural Elevator Buckets (Centrifugal discharge)



| ELEVATOR BUCKET NOMINAL PROJ. (INCHES) | | MINIMUM AND OPTIMUM PULLEY SPEEDS | | | | | | | | | | | | | | | | |
|--|----------|--|-------|-------|-------|-------|-------|-------|-------|-------|-------|-------|-------|--------|--------|--------|--------|--------|
| | | PULLEY DIAMETER (INCHES) / PULLEY CIRCUMFERENCE (FEET) | | | | | | | | | | | | | | | | |
| | | 4" | 5" | 6" | 8" | 10" | 12" | 14" | 16" | 20" | 24" | 30" | 36" | 42" | 48" | 60" | 72" | 84" |
| | | 1.05' | 1.31' | 1.57' | 2.07' | 2.62' | 3.14' | 3.67' | 4.19' | 5.24' | 6.28' | 7.85' | 9.42' | 11.00' | 12.57' | 15.70' | 18.90' | 22.00' |
| 3" | Minimum: | 89 | 80 | 81 | 74 | 69 | 64 | - | - | - | - | - | - | - | - | - | - | - |
| | Optimum: | 158 | 143 | 131 | 115 | 103 | 95 | - | - | - | - | - | - | - | - | - | - | - |
| 4" | Minimum: | - | - | 75 | 70 | 53 | 51 | 50 | 46 | 43 | 40 | - | - | - | - | - | - | - |
| | Optimum: | - | - | 146 | 127 | 109 | 103 | 96 | 89 | 79 | 72 | - | - | - | - | - | - | - |
| 5" | Minimum: | - | - | - | 70 | 67 | 63 | 50 | 48 | 45 | 40 | 40 | 35 | 32 | 32 | - | - | - |
| | Optimum: | - | - | - | 161 | 131 | 111 | 102 | 95 | 90 | 75 | 67 | 61 | 55 | 51 | - | - | - |
| 6" | Minimum: | - | - | - | - | - | - | - | 50 | 45 | 40 | 36 | 35 | 31 | 30 | - | - | - |
| | Optimum: | - | - | - | - | - | - | - | 93 | 84 | 73 | 67 | 61 | 55 | 51 | - | - | - |
| 7" | Minimum: | - | - | - | - | - | - | - | - | 40 | 36 | 34 | 33 | 31 | 30 | 27 | 26 | 20 |
| | Optimum: | - | - | - | - | - | - | - | - | 80 | 78 | 73 | 65 | 59 | 55 | 50 | 45 | 40 |
| 8" | Minimum: | - | - | - | - | - | - | - | - | - | - | 33 | 32 | 30 | 30 | 27 | 25 | 23 |
| | Optimum: | - | - | - | - | - | - | - | - | - | - | 60 | 58 | 57 | 56 | 47 | 43 | 40 |
| 10" | Minimum: | - | - | - | - | - | - | - | - | - | - | - | - | - | 30 | 25 | 20 | 20 |
| | Optimum: | - | - | - | - | - | - | - | - | - | - | - | - | - | 52 | 45 | 42 | 40 |

TIGER-CC®, CC-MAX® TABLE OF SPEEDS

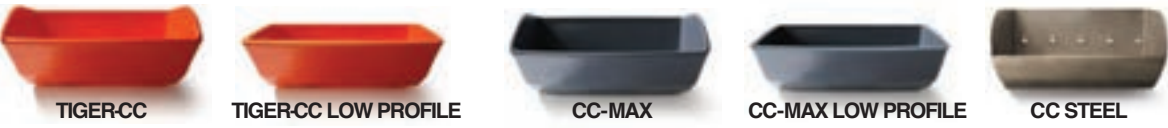

| CC-MAX TABLE OF SPEEDS | | | | | |
|----------------------------------|---------------------------------------|----------|----------|----------|----------|
| PULLEY / SPROCKET DIAMETER (IN.) | PULLEY / SPROCKET CIRCUMFERENCE (FT.) | MIN. RPM | MAX. RPM | MIN. FPM | MAX. FPM |
| 8" | 2.09 | 85 | 170 | 178 | 356 |
| 10" | 2.62 | 85 | 170 | 223 | 445 |
| 12" | 3.14 | 75 | 145 | 236 | 456 |
| 14" | 3.67 | 65 | 120 | 238 | 440 |
| 16" | 4.19 | 55 | 100 | 230 | 419 |
| 18" | 4.71 | 55 | 90 | 259 | 424 |
| 20" | 5.24 | 55 | 85 | 288 | 445 |
| 22" | 5.76 | 55 | 85 | 288 | 445 |
| 24" | 6.28 | 42 | 80 | 264 | 503 |
| 30" | 7.85 | 42 | 80 | 330 | 628 |
| 36" | 9.42 | 42 | 80 | 396 | 754 |
| 42" | 11.00 | 40 | 70 | 440 | 770 |
| 48" | 12.57 | 40 | 65 | 503 | 817 |
| 54" | 14.14 | 40 | 65 | 566 | 919 |
| 60" | 15.71 | 40 | 60 | 628 | 942 |
| 72" | 18.85 | 40 | 55 | 754 | 1037 |
| 84" | 22.00 | 34 | 50 | 748 | 1100 |
| 96" | 25.13 | 30 | 45 | 754 | 1131 |

MINIMUM SPEED: Slowest Speed at which Centrifugal Discharge will occur.
OPTIMUM SPEED: Speed at which most desirable results are obtained.
MAXIMUM SPEED: Maximum Speed is governed by many factors including Bonnet Shape, clearances, throat location, desired capacity and commodity elevated, therefore is not published.

The optimum speeds shown are based on free flowing whole grains. The optimum recommended speed for feed ingredients and other similar materials is 85% of the optimum speed shown.

These tables are for general reference only and do not guarantee perfect discharge for all bucket elevators at all speeds shown within speed range.

*Note: Low profile buckets may require faster minimum speeds than shown on this chart at minimum spacing.

SPEED CHART / HEAD SHAFT RATING

For More Information, Call 1-800-527-0657

DURA-BUKET® AGRICULTURAL ELEVATOR BUCKET SPEED CHART

Recommended Minimum and Optimum Pulley Speeds for DURA-BUKET Agricultural Elevator Buckets (Centrifugal Discharge)



DURA-BUKET SS



DURA-BUKET LP

DURA-BUKET MINIMUM AND OPTIMUM PULLEY SPEEDS

| ELEVATOR BUCKET NOMINAL PROJ. (INCHES) | | PULLEY DIAMETER (INCHES) / PULLEY CIRCUMFERENCE (FEET) | | | | | | | | | | | | | | | |
|--|----------|--|-------|-------|-------|-------|-------|-------|-------|-------|--------|--------|--------|--------|--------|--------|--------|
| | | 10" | 12" | 16" | 18" | 20" | 22" | 24" | 30" | 36" | 42" | 48" | 54" | 60" | 72" | 84" | 96" |
| | | 2.62' | 3.14' | 4.19' | 4.71' | 5.24' | 5.76' | 6.28' | 7.85' | 9.42' | 11.00' | 12.57' | 14.14' | 15.70' | 18.90' | 22.00' | 25.13' |
| 3" | Minimum: | 85 | 75 | 55 | 55 | 55 | 55 | - | - | - | - | - | - | - | - | - | |
| | Optimum: | 144 | 121 | 90 | 81 | 76 | 72 | - | - | - | - | - | - | - | - | - | |
| 4" | Minimum: | - | 75 | 55 | 55 | 55 | 55 | 50 | - | - | - | - | - | - | - | - | |
| | Optimum: | - | 121 | 90 | 81 | 76 | 72 | 72 | - | - | - | - | - | - | - | - | |
| 5" | Minimum: | - | - | - | 55 | 55 | 55 | 50 | 42 | 42 | 40 | - | - | - | - | - | |
| | Optimum: | - | - | - | 81 | 76 | 72 | 72 | 72 | 72 | 63 | - | - | - | - | - | |
| 6" | Minimum: | - | - | - | - | - | - | 50 | 42 | 42 | 40 | 40 | 40 | 40 | - | - | |
| | Optimum: | - | - | - | - | - | - | 72 | 72 | 72 | 63 | 58 | 58 | 54 | - | - | |
| 7" | Minimum: | - | - | - | - | - | - | - | 42 | 42 | 40 | 40 | 40 | 40 | 40 | 34 | |
| | Optimum: | - | - | - | - | - | - | - | 72 | 72 | 63 | 58 | 58 | 54 | 49 | 45 | |
| 8" | Minimum: | - | - | - | - | - | - | - | - | - | - | 40 | 40 | 40 | 40 | 34 | |
| | Optimum: | - | - | - | - | - | - | - | - | - | - | 58 | 58 | 54 | 49 | 45 | |

HEAD SHAFT DIAMETER PER HORSEPOWER RATING

| HORSEPOWER | SHAFT DIAMETER (INCHES) |
|------------|-------------------------|
| 1-2 | 1-7/16 |
| 3 | 1-15/16 |
| 5 | 2-3/16 |
| 7 1/2 - 10 | 2-7/16 |
| 15 | 2-15/16 |
| 20 | 3-3/16 |
| 25-30 | 3-7/16 |
| 40 | 3-15/16 |
| 50 - 60 | 4-7/16 |
| 75 - 100 | 4-15/16 |
| 125 | 5-7/16 |
| 150 | 5-15/16 |
| 200 | 7 |
| 250 | 7 |

MINIMUM SPEED: Slowest Speed at which Centrifugal Discharge will occur.
OPTIMUM SPEED: Speed at which most desirable results are obtained.
MAXIMUM SPEED: Maximum Speed is governed by many factors including Bonnet Shape, clearances, throat location and desired capacity.

This table is for general reference only and does not guarantee perfect discharge for all bucket elevators at all speeds shown within speed range.
 Note: Low-Profile Elevator Buckets spaced on minimum centers may require faster minimum speeds than shown on this chart.

The optimum speeds shown are based on free flowing whole grains. The maximum recommended speed for feed ingredients and other similar materials is 85% of the optimum speed shown.

This table is provided for general reference only. Maxi-Lift assumes no liability from use of these figures.

INDUSTRIAL SPEED CHARTS

For More Information, Visit WWW.MAXILIFT.COM

INDUSTRIAL ELEVATOR BUCKET SPEED CHART

Recommended Minimum and Optimum Pulley Speeds for Maxi-Tuff / Tiger-Tuff industrial Elevator Buckets (Centrifugal Discharge)



| ELEVATOR BUCKET NOMINAL PROJ. (INCHES) | | MINIMUM AND OPTIMUM PULLEY SPEEDS | | | | | | | | | | | |
|--|----------|--|-------|-------|-------|-------|-------|-------|-------|-------|-------|--------|--------|
| | | PULLEY DIAMETER (INCHES) / PULLEY CIRCUMFERENCE (FEET) | | | | | | | | | | | |
| | | 6" | 8" | 10" | 12" | 16" | 18" | 20" | 24" | 30" | 36" | 42" | 48" |
| | | 1.57' | 2.07' | 2.62' | 3.14' | 4.19' | 4.71' | 5.24' | 6.28' | 7.85' | 9.42' | 11.00' | 12.57' |
| 3" | Minimum: | 80 | 73 | 67 | 62 | - | - | - | - | - | - | - | - |
| | Optimum: | 85 | 77 | 71 | 66 | - | - | - | - | - | - | - | - |
| | Maximum: | 90 | 81 | 75 | 70 | - | - | - | - | - | - | - | - |
| 4" | Minimum: | - | - | 65 | 60 | 54 | - | - | - | - | - | - | - |
| | Optimum: | - | - | 68 | 64 | 57 | - | - | - | - | - | - | - |
| | Maximum: | - | - | 72 | 67 | 60 | - | - | - | - | - | - | - |
| 5" | Minimum: | - | - | - | 59 | 53 | 51 | 48 | - | - | - | - | - |
| | Optimum: | - | - | - | 62 | 55 | 53 | 51 | - | - | - | - | - |
| | Maximum: | - | - | - | 65 | 59 | 57 | 54 | - | - | - | - | - |
| 6" | Minimum: | - | - | - | - | 52 | 49 | 47 | 44 | - | - | - | - |
| | Optimum: | - | - | - | - | 54 | 52 | 50 | 46 | - | - | - | - |
| | Maximum: | - | - | - | - | 57 | 55 | 53 | 49 | - | - | - | - |
| 7" | Minimum: | - | - | - | - | 50 | 48 | 46 | 43 | 40 | - | - | - |
| | Optimum: | - | - | - | - | 53 | 51 | 49 | 46 | 42 | - | - | - |
| | Maximum: | - | - | - | - | 56 | 54 | 52 | 48 | 44 | - | - | - |
| 8" | Minimum: | - | - | - | - | - | - | 46 | 43 | 39 | 36 | 34 | - |
| | Optimum: | - | - | - | - | - | - | 48 | 45 | 41 | 38 | 36 | - |
| | Maximum: | - | - | - | - | - | - | 51 | 48 | 44 | 41 | 38 | - |
| 10" | Minimum: | - | - | - | - | - | - | - | 41 | 38 | 36 | 33 | 32 |
| | Optimum: | - | - | - | - | - | - | - | 45 | 40 | 37 | 35 | 33 |
| | Maximum: | - | - | - | - | - | - | - | 46 | 43 | 40 | 37 | 35 |

MAXI-TUFF INDUSTRIAL MF ELEVATOR BUCKET SPEED CHART

This table is for general reference only and does not guarantee perfect discharge for all bucket elevators at all speeds shown within speed range. Recommended Minimum Spacing, Pulley Diameter and Speeds for Maxi-Tuff MF Elevator Buckets (Continuous Discharge)



| BUCKET PROJECTION | BUCKET SIZE | MINIMUM SPACING (INCHES) | MINIMUM DIAMETER (INCHES) | MAXIMUM FPM |
|-------------------|-------------|--------------------------|---------------------------|-------------|
| 5" | 8 x 5 x 7 | 7-1/2 | 10 | 250 |
| | 10 x 5 x 7 | | | |
| 7" | 12 x 7 x 11 | 11-1/4 | 18 | 250 |
| | 14 x 7 x 11 | | | |
| | 16 x 7 x 11 | | | |
| 8" | 12 x 8 x 11 | 11-1/4 | 18 | 250 |
| | 14 x 8 x 11 | | | |
| | 16 x 8 x 11 | | | |
| | 18 x 8 x 11 | | | |

PUNCHING REFERENCE CHART

Agricultural Elevator Buckets

PUNCHING FOR AGRICULTURAL ELEVATOR BUCKETS: STANDARD HOLE CENTERS

| BUCKET SIZE, IN. | TIGER-TUFF | TIGER-CC | HD-MAX | CC-MAX | DURA-BUKET SS | DURA-BUKET LP | CC STEEL |
|------------------|------------|----------|--------|---------|---------------|---------------|----------|
| 3 x 2 | - | - | 1-3/4 | - | - | - | - |
| 4 x 3 | - | - | 2-1/4 | - | 2-1/4 | 2-1/4 | 2-1/2 |
| 4 x 4 | - | - | - | - | - | - | 2-1/2 |
| 5 x 4 | - | - | 3-3/16 | 3-3/16 | 3-3/16 | 3-3/16 | 3-3/16 |
| 6 x 4 | - | - | 4-3/8 | 4-3/8 | 4-3/8 | 4-1/4 | 4-3/8 |
| 7 x 4 | - | - | 2-5/8 | 2-11/16 | 2-11/16 | 2-5/8 | 2-11/16 |
| 8 x 4 | - | - | - | - | - | - | 3-1/16 |
| 9 x 4 | - | - | - | - | - | - | 3-5/8 |
| 6 x 5 | 4-3/8 | - | 4-3/8 | 4-3/8 | 4-3/8 | 4-1/4 | 4-3/8 |
| 7 x 5 | 2-11/16 | - | 2-5/8 | 2-11/16 | 2-5/8 | 2-5/8 | 2-11/16 |
| 8 x 5 | 3-1/16 | - | 3-1/16 | 3-1/16 | 3-1/16 | 3-1/16 | 3-1/16 |
| 9 x 5 | 3-5/8 | - | 3-1/2 | 3-5/8 | 3-1/4 | 3-1/4 | 3-5/8 |
| 10 x 5 | 4-1/8 | - | 4 | 4-1/8 | - | - | 4-1/8 |
| 11 x 5 | 3 | - | 3-1/8 | 3 | - | - | 3 |
| 12 x 5 | 3-3/8 | - | 3-3/8 | - | - | - | 3-3/8 |
| 8 x 6 | 3-1/16 | - | 3-1/16 | 3-1/16 | 3-1/16 | 2-11/16 | 3-1/16 |
| 9 x 6 | 3-5/8 | - | 3-1/2 | 3-5/8 | 3-1/2 | 3-1/2 | 3-5/8 |
| 10 x 6 | 4-1/8 | - | 4 | 4-1/8 | 4 | 4 | 4-1/8 |
| 11 x 6 | 3 | - | 3 | 3 | 3 | 2-7/8 | 3 |
| 12 x 6 | 3-3/8 | - | 3-3/8 | 3-3/8 | 3-3/8 | 3-1/4 | 3-3/8 |
| 13 x 6 | 3-5/8 | - | 3-5/8 | 3-5/8 | 3-5/8 | 3-5/8 | 3-5/8 |
| 8 x 7 | - | - | - | - | - | - | 3-1/16 |
| 9 x 7 | - | - | - | - | - | - | 3-5/8 |
| 10 x 7 | - | - | 4 | 4-1/8 | 4 | 4 | 4-1/8 |
| 11 x 7 | - | - | 3 | 3 | 3 | 3 | 3 |
| 12 x 7 | 3-3/8 | - | 3-3/8 | 3-3/8 | 3-3/8 | 3-1/4 | 3-3/8 |
| 13 x 7 | 3-5/8 | - | 3-5/8 | 3-5/8 | 3-5/8 | 3-5/8 | 3-5/8 |
| 14 x 7 | 3 | - | 3 | 3 | 3 | 4 | 3 |
| 15 x 7 | 3-1/4 | - | 3-1/4 | 3-1/4 | 3-1/4 | 2-5/8 | 3-1/4 |
| 16 x 7 | 2-7/8 | - | 3-1/2 | 2-7/8 | 3-1/2 | 2-5/8 | 2-7/8 |
| 18 x 7 | - | - | - | - | - | - | 3-1/8 |
| 20 x 7 | - | - | - | - | - | - | 3-1/2 |
| 22 x 7 | - | - | - | - | - | - | 4 |
| 24 x 7 | - | - | - | - | - | - | 3-1/2 |
| 9 x 8 | - | - | - | - | - | - | 3-5/8 |
| 10 x 8 | - | - | 4-1/8 | - | - | - | 4-1/8 |
| 11 x 8 | 3 | - | 3-1/8 | - | - | - | 3 |
| 12 x 8 | 3-3/8 | 3-3/8 | 3-3/8 | 3-3/8 | 3-3/8 | 3-1/4 | 3-3/8 |
| 13 x 8 | 3-5/8 | - | - | 3-5/8 | - | - | 3-5/8 |
| 14 x 8 | 3 | 3 | 3 | 3 | 3 | 4 | 3 |
| 15 x 8 | - | - | 3-1/4 | - | - | - | 3-1/4 |
| 16 x 8 | 2-7/8 | 2-7/8 | 3-1/2 | 2-7/8 | 3-1/2 | 2-5/8 | 2-7/8 |
| 17 x 8 | - | - | - | - | - | - | 3 |
| 18 x 8 | 3-1/8 | 3-1/8 | 3-1/8 | 3-1/8 | 3-1/8 | 3-1/8 | 3-1/8 |
| 20 x 8 | 3-1/2 | 3-1/2 | - | 3-1/2 | - | - | 3-1/2 |
| 22 x 8 | 4 | - | - | - | - | - | 4 |
| 24 x 8 | 3-1/2 | - | - | - | - | - | 3-1/2 |
| 16 x 10 | 2-7/8 | - | - | - | - | - | - |
| 18 x 10 | 3-1/8 | - | - | - | - | - | - |
| 20 x 10 | 3-1/2 | 3-1/2 | - | - | - | - | - |
| 21 x 10 | - | 3-5/8 | - | - | - | - | - |
| 22 x 10 | - | 4 | - | - | - | - | - |
| 23 x 10 | - | 3-3/8 | - | - | - | - | - |
| 24 x 10 | - | 3-1/2 | - | - | - | - | - |
| 25 x 10 | - | 3-5/8 | - | - | - | - | - |
| 26 x 10 | - | 3-7/8 | - | - | - | - | - |
| 27 x 10 | - | 3-3/8 | - | - | - | - | - |
| 28 x 10 | - | 3-5/8 | - | - | - | - | - |

Chart shows Standard Punching - Special Punching available on request. Please double check all punching with original manufacturer.

BUCKET PUNCHING: CHAINS

Call 1-800-527-0657, Visit MAXILIFT.COM for More Info

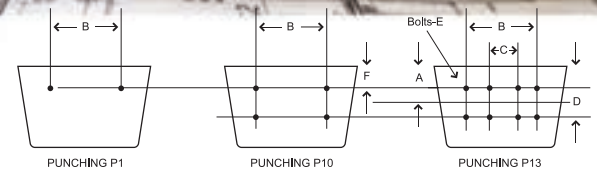

PUNCHING: CENTRIFUGAL DISCHARGE ELEVATOR BUCKETS ON "K" ATTACHMENTS

| CHAIN ATTACHMENT NUMBER | NOMINAL BUCKET SIZE, INCHES | | | | | | PUNCHING | INCHES | | | | | |
|-------------------------|-----------------------------|---------|---------|---------|---------|--------|----------|--------|--------|---|--------|------|---|
| | TYPES AA, AA-RB | | TYPE AC | | TYPE SC | | | A | B | C | D | E | F |
| | Min. | Max. | Min. | Max. | Min. | Max. | | | | | | | |
| 77-K1 | 6 x 4 | 10 x 6 | - | - | 8 x 6 | 10 x 8 | P1 | - | 3 | - | - | 1/4 | 1 |
| 77-K2 | 6 x 4 | 10 x 6 | - | - | 8 x 6 | 10 x 8 | P10 | - | 3 | - | 13/16 | 1/4 | 1 |
| C 77-K1 | 6 x 4 | 10 x 6 | - | - | 8 x 6 | 10 x 8 | P1 | - | 3 | - | - | 3/8 | 1 |
| 78-K1 | 6 x 4 | 10 x 6 | - | - | 8 x 6 | 10 x 8 | P1 | - | 3-3/8 | - | - | 1/4 | 1 |
| H 78-K1 | 6 x 4 | 12 x 6 | - | - | 8 x 6 | 12 x 8 | P1 | - | 4 | - | - | 3/8 | 1 |
| H 78-K2 | 6 x 4 | 12 x 6 | - | - | 8 x 6 | 12 x 8 | P10 | - | 4 | - | 1-1/8 | 3/8 | 1 |
| C 102B-K2 | 8 x 5 | 16 x 7 | - | - | 8 x 6 | 16 x 8 | P10 | - | 5-5/16 | - | 1-3/4 | 3/8 | 1 |
| SS 102B-K2 | 7 x 4-1/2 | 16 x 7 | - | - | 8 x 6 | 16 x 8 | P10 | - | 5-5/16 | - | 1-3/4 | 3/8 | 1 |
| C 102-1/2-K2 | 8 x 5 | 16 x 7 | - | - | 8 x 6 | 16 x 8 | P10 | - | 5-5/16 | - | 1-3/4 | 1/2 | 1 |
| SS 102-1/2-K2 | 8 x 5 | 16 x 7 | - | - | 8 x 6 | 16 x 8 | P10 | - | 5-5/16 | - | 1-3/4 | 1/2 | 1 |
| C 110-K2 | 8 x 5 | 16 x 7 | - | - | 8 x 6 | 16 x 8 | P10 | - | 5-5/16 | - | 1-3/4 | 3/8 | 1 |
| SS 110-K2 | 8 x 5 | 16 x 7 | - | - | 8 x 6 | 16 x 8 | P10 | - | 5-5/16 | - | 1-3/4 | 3/8 | 1 |
| C111-K2 | 9 x 6 | 18 x 8 | - | - | 10 x 8 | 16 x 8 | P10 | - | 6-1/4 | - | 2-5/16 | 1/2 | 1 |
| SS 111-K2 | 10 x 6 | 18 x 8 | - | - | 10 x 8 | 16 x 8 | P10 | - | 6-1/4 | - | 2-5/16 | 1/2 | 1 |
| C 132-K2 | 12 x 6 | 20 x 8 | - | - | 12 x 8 | 16 x 8 | P10 | - | 7-1/2 | - | 2-3/4 | 1/2 | 1 |
| 188-K1 | 6 x 4 | 12 x 6 | - | - | 8 x 6 | 12 x 6 | P1 | - | 3-3/4 | - | - | 3/8 | 1 |
| C 188-K2 | 6 x 4 | 14 x 7 | - | - | 8 x 6 | 14 x 8 | P10 | - | 4-3/16 | - | 1-1/4 | 5/16 | 1 |
| SS 188-K1 | 6 x 4 | 12 x 6 | - | - | 8 x 6 | 12 x 8 | P1 | - | 3-3/4 | - | - | 3/8 | 1 |
| SS 188-K2 | 8 x 5 | 14 x 7 | - | - | 8 x 6 | 14 x 8 | P10 | - | 4-3/16 | - | 1-1/4 | 5/16 | 1 |
| SS 856-K2 | 10 X 6 | 18 X 10 | - | - | 10 X 8 | 16 X 8 | P10 | - | 6-5/16 | - | 2-1/4 | 1/2 | 1 |
| SS 856-K24 | - | - | 18 x 10 | 24 x 10 | - | - | P10 | - | 7-1/4 | - | 2-1/2 | 5/8 | 1 |
| SS 2857-K44 | - | - | 18 x 10 | 24 x 10 | - | - | P13 | - | 12 | - | 3-1/2 | 1/2 | 1 |

* Some chain punches may incur additional punching charges. Contact Maxi-Lift for details.

PUNCHING: CONTINUOUS ELEVATOR BUCKETS ON "K" ATTACHMENTS

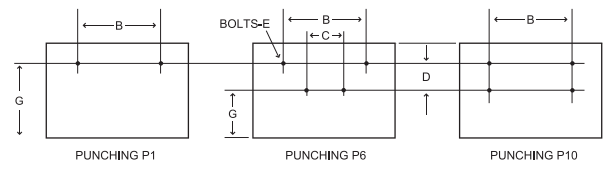

| CHAIN ATTACHMENT NUMBER | NOMINAL BUCKET SIZE, INCHES | | | | | | | | PUNCHING | INCHES | | | | |
|-------------------------|-----------------------------|--------|----------|--------|---------|--------|---------|--------|----------|--------|---|--------|-----|--------|
| | TYPE HF | | TYPE HFO | | TYPE MF | | TYPE LF | | | B | C | D | E | G |
| | Min. | Max. | Min. | Max. | Min. | Max. | Min. | Max. | | | | | | |
| C 102B-K2 | 8 x 5 | 10 x 5 | 8 x 5 | 10 x 5 | 8 x 5 | 10 x 5 | - | - | P10 | 5-5/16 | - | 1-3/4 | 3/8 | 1-7/8 |
| SS 102B-K2 | 8 x 5 | 10 x 5 | 8 x 5 | 10 x 5 | 8 x 5 | 10 x 5 | - | - | P10 | 5-5/16 | - | 1-3/4 | 3/8 | 1-7/8 |
| C 102B-1/2-K2 | 8 x 5 | 10 x 5 | 8 x 5 | 10 x 5 | 8 x 5 | 10 x 5 | - | - | P10 | 5-5/16 | - | 1-3/4 | 1/2 | 1-7/8 |
| SS 102B-1/2-K2 | 8 x 5 | 10 x 5 | 8 x 5 | 10 x 5 | 8 x 5 | 10 x 5 | - | - | P10 | 5-5/16 | - | 1-3/4 | 1/2 | 1-7/8 |
| C 110-K2 | 10 x 7 | 16 x 8 | 10 x 7 | 16 x 8 | 10 x 7 | 18 x 8 | 10 x 7 | 16 x 8 | P10 | 5-5/16 | - | 1-3/4 | 3/8 | 3-3/8 |
| SS 110-K2 | 10 x 7 | 16 x 8 | 10 x 7 | 16 x 8 | 10 x 7 | 18 x 8 | 10 x 7 | 16 x 8 | P10 | 5-5/16 | - | 1-3/4 | 3/8 | 3-3/8 |
| C 111-K2 | 10 x 6 | 12 x 6 | 10 x 6 | 12 x 6 | 10 x 6 | 12 x 6 | 10 x 6 | 12 x 6 | P10 | 6-1/4 | - | 2-5/16 | 1/2 | 2-3/32 |
| SS 111-K2 | 10 x 6 | 12 x 6 | 10 x 6 | 12 x 6 | 10 x 6 | 12 x 6 | 10 x 6 | 12 x 6 | P10 | 6-1/4 | - | 2-5/16 | 1/2 | 2-3/32 |
| C 132-K2 | 10 x 7 | 16 x 8 | 10 x 7 | 16 x 8 | 12 x 7 | 20 x 8 | 12 x 7 | 20 x 8 | P10 | 7-1/2 | - | 2-3/4 | 1/2 | 2-7/8 |
| SS 150PLUS-K2 | 10 x 7 | 16 x 8 | 10 x 7 | 16 x 8 | 12 x 7 | 20 x 8 | 12 x 7 | 20 x 8 | P10 | 7-1/2 | - | 2-3/4 | 1/2 | 2-7/8 |
| SS 856-K2 | 10 x 7 | 16 x 8 | 10 x 7 | 16 x 8 | 12 x 7 | 20 x 8 | 12 x 7 | 20 x 8 | P10 | 6-5/16 | - | 2-1/4 | 3/8 | 3-1/8 |

Other Chain Punches Available. **Verify Bucket Punching Before Ordering.**

BUCKET PUNCHING: BELTS

For More Information, Call 1-800-527-0657

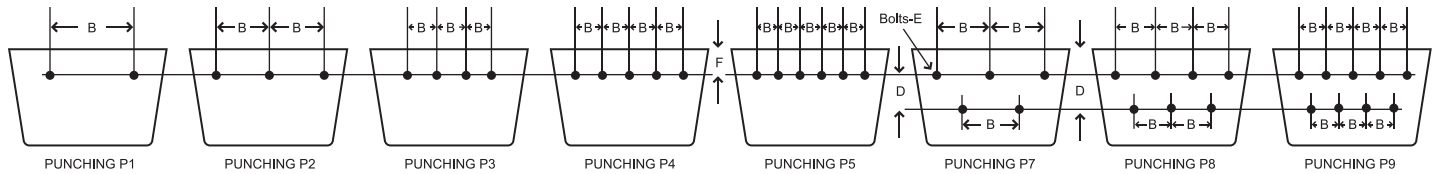

PUNCHING: TYPES HF, HFO, MF AND LF

| TYPES HF, HFO, MF AND LF CONTINUOUS ELEVATOR BUCKETS FOR BELTS | | | | | | | | |
|--|----------|-----------|----------|-------------------|--------|---|------|---------|
| BUCKET SIZE, INCHES | | | PUNCHING | BELT WIDTH INCHES | INCHES | | | |
| L - Length | P - Proj | D - Depth | | | B | D | E | F |
| 8 | 5 | 7-3/4 | P7 | 9-10 | 3 | 1 | 1/4 | 3-3/8 |
| 8 | 5 | 8-1/2 | P7 | 9-10 | 3 | 1 | 1/4 | 3-3/4 |
| 9 | 6 | 9-1/4 | P7 | 10 | 3 | 1 | 1/4 | 4-1/8 |
| 10 | 5 | 7-3/4 | P7 | 11-12 | 3-1/2 | 1 | 5/16 | 3-3/8 |
| 10 | 5 | 8-1/2 | P7 | 11-12 | 3-1/2 | 1 | 5/16 | 3-3/4 |
| 10 | 6 | 9-1/4 | P7 | 11-12 | 3-1/2 | 1 | 5/16 | 4-1/8 |
| 10 | 6 | 10 | P7 | 11-12 | 3-1/2 | 1 | 5/16 | 4-1/2 |
| 10 | 7 | 11-5/8 | P7 | 11-12 | 3-1/2 | 1 | 5/16 | 5-5/16 |
| 10 | 7 | 12-1/2 | P7 | 11-12 | 3-1/2 | 1 | 5/16 | 5-3/4 |
| 10 | 8 | 11-5/8 | P7 | 11-12 | 3-1/2 | 1 | 5/16 | 5-5/16 |
| 11 | 6 | 9-1/4 | P7 | 12 | 4 | 1 | 5/16 | 4-1/8 |
| 12 | 5 | 7-3/4 | P7 | 13-14 | 4-1/2 | 1 | 5/16 | 3-3/8 |
| 12 | 6 | 9-1/4 | P7 | 13-14 | 4-1/2 | 1 | 5/16 | 4-1/8 |
| 12 | 6 | 10 | P7 | 13-14 | 4-1/2 | 1 | 5/16 | 4-1/2 |
| 12 | 7 | 11-5/8 | P7 | 13-14 | 4-1/2 | 1 | 5/16 | 5-5/16 |
| 12 | 7 | 11-3/4 | P7 | 13-14 | 4-1/2 | 1 | 5/16 | 5-3/8 |
| 12 | 7 | 12-1/2 | P7 | 13-14 | 4-1/2 | 1 | 5/16 | 5-3/4 |
| 12 | 8 | 11-5/8 | P7 | 13-14 | 4-1/2 | 1 | 5/16 | 5-5/16 |
| 12 | 8 | 12-1/2 | P7 | 13-14 | 4-1/2 | 1 | 5/16 | 5-3/4 |
| 14 | 7 | 11-5/8 | P8 | 15-16 | 4 | 1 | 5/16 | 5-5/16 |
| 14 | 7 | 12-1/2 | P8 | 15-16 | 4 | 1 | 5/16 | 5-3/4 |
| 14 | 8 | 11-5/8 | P8 | 15-16 | 4 | 1 | 5/16 | 5-5/16 |
| 14 | 8 | 11-3/4 | P8 | 15-16 | 4 | 1 | 5/16 | 5-3/8 |
| 14 | 8 | 12-1/2 | P8 | 15-16 | 4 | 1 | 5/16 | 5-3/4 |
| 16 | 7 | 11-3/4 | P8 | 18 | 4-1/2 | 1 | 5/16 | 5-3/8 |
| 16 | 8 | 11-5/8 | P8 | 18 | 4-1/2 | 1 | 5/16 | 5-5/16 |
| 16 | 8 | 12-1/2 | P8 | 18 | 4-1/2 | 1 | 5/16 | 5-3/4 |
| 16 | 12 | 17-5/8 | P8 | 18 | 4-1/2 | 1 | 5/16 | 8-5/16 |
| 16 | 12 | 18-5/8 | P8 | 18 | 4-1/2 | 1 | 5/16 | 8-13/16 |
| 18 | 8 | 11-5/8 | P8 | 20 | 5 | 1 | 5/16 | 5-5/16 |
| 18 | 10 | 15 | P8 | 20 | 5 | 1 | 5/16 | 7 |
| 20 | 8 | 11-5/8 | P9 | 22 | 4 | 1 | 5/16 | 5-5/16 |
| 20 | 12 | 17-5/8 | P9 | 22 | 4 | 1 | 5/16 | 8-5/16 |
| 20 | 12 | 18-5/8 | P9 | 22 | 4 | 1 | 5/16 | 8-13/16 |
| 24 | 10 | 11-5/8 | P9 | 26 | 5 | 1 | 5/16 | 5-5/16 |
| 24 | 12 | 17-5/8 | P9 | 26 | 5 | 1 | 5/16 | 8-5/16 |
| 24 | 12 | 18-5/8 | P9 | 26 | 5 | 1 | 5/16 | 8-13/16 |

All plastic Maxi-Tuff MF Buckets that have a depth of 11-1/2", 11-5/8" or 11-3/4" will be punched with a 5-5/16" down dimension (F).

BUCKET PUNCHING: BELTS

For More Information, Visit WWW.MAXILIFT.COM

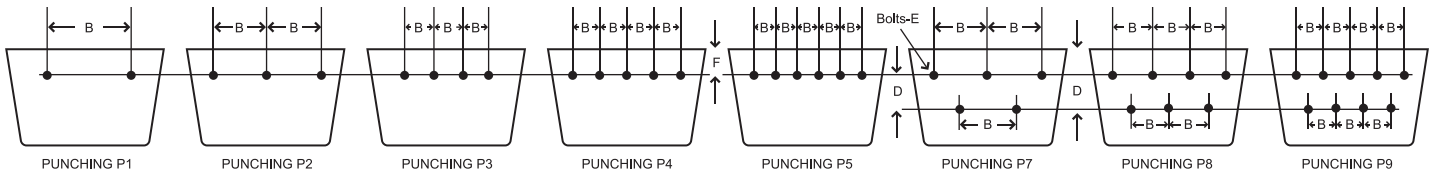

PUNCHING: TYPES AA, TIGER-TUFF AND TIGER-CC INDUSTRIAL

TYPES AA, TIGER-TUFF & TIGER-CC INDUSTRIAL CENTRIFUGAL DISCHARGE ELEVATOR BUCKETS FOR BELTS

| NOMINAL BUCKET LENGTH INCHES | PUNCHING | BELT WIDTH INCHES | B | D | E | F |
|------------------------------|----------|-------------------|--------|---|------|---|
| 3 | P1 | 4 | 1-3/8 | — | 1/4 | 1 |
| 4 | P1 | 5 | 2-5/16 | — | 1/4 | 1 |
| 5 | P1 | 6 | 3-3/16 | — | 1/4 | 1 |
| 6 | P1 | 7-8 | 4-3/8 | — | 1/4 | 1 |
| 7 | P2 | 8 | 2-1/2 | — | 1/4 | 1 |
| 8 | P7 | 9-10 | 3 | 1 | 1/4 | 1 |
| 9 | P7 | 10 | 3 | 1 | 1/4 | 1 |
| 10 | P7 | 11-12 | 3-1/2 | 1 | 5/16 | 1 |
| 11 | P7 | 12 | 4 | 1 | 5/16 | 1 |
| 12 | P7 | 13-14 | 4-1/2 | 1 | 5/16 | 1 |
| 13 | P8 | 14 | 3-1/2 | 1 | 5/16 | 1 |
| 14 | P8 | 15-16 | 4 | 1 | 5/16 | 1 |
| 15 | P8 | 16 | 4 | 1 | 5/16 | 1 |
| 16 | P8 | 18 | 4-1/2 | 1 | 5/16 | 1 |
| 17 | P8 | 18 | 4-1/2 | 1 | 5/16 | 1 |
| 18 | P8 | 20 | 5 | 1 | 5/16 | 1 |
| 19 | P9 | 20 | 4 | 1 | 5/16 | 1 |
| 20 | P9 | 22 | 4 | 1 | 5/16 | 1 |
| 21 | P9 | 22 | 4-1/2 | 1 | 5/16 | 1 |
| 22 | P9 | 24 | 4-1/2 | 1 | 5/16 | 1 |
| 23 | P9 | 24 | 5 | 1 | 5/16 | 1 |
| 24 | P9 | 26 | 5 | 1 | 5/16 | 1 |

Other Belt Punches Available. **Verify Bucket Punching Before Ordering.**

BUCKET ELEVATOR QUESTIONNAIRE

Please complete and Fax to: (972)735-8896

CLIENT INFORMATION

COMPANY: _____

ADDRESS: _____

LOCATION : _____

1. CURRENT BUCKET SIZE: _____

2. CURRENT BUCKET STYLE: _____

3. BUCKET MANUFACTURER: _____

4. BUCKET SPACING ON BELT: _____

5. NUMBER OF BUCKET ROWS: _____

6. PRODUCT BEING ELEVATED: _____

7. PRODUCT DENSITY: _____

8. MOISTURE: _____

9. OIL OR FAT CONTENT: _____

10. PARTICLE SIZE: _____

11. PRODUCT TEMPERATURE: _____

12. HEAD PULLEY DIAMETER: _____

13. HEAD PULLEY WIDTH: _____

14. HEAD SHAFT DIAMETER: _____

15. HEAD SHAFT RPM: _____

16. MOTOR HORSEPOWER: _____

17. BOOT PULLEY DIAMETER: _____

18. FEED INLET, UP OR DOWN LEG: _____

19. FEED INLET, OPENING WIDTH: _____

20. BUCKET ELEVATOR MANUFACTURER: _____

21. REQUIRED CAPACITY: _____

22. CURRENT CAPACITY: _____

CONTACT: _____

REF: _____

EMAIL: _____

PHONE: _____ FAX: _____

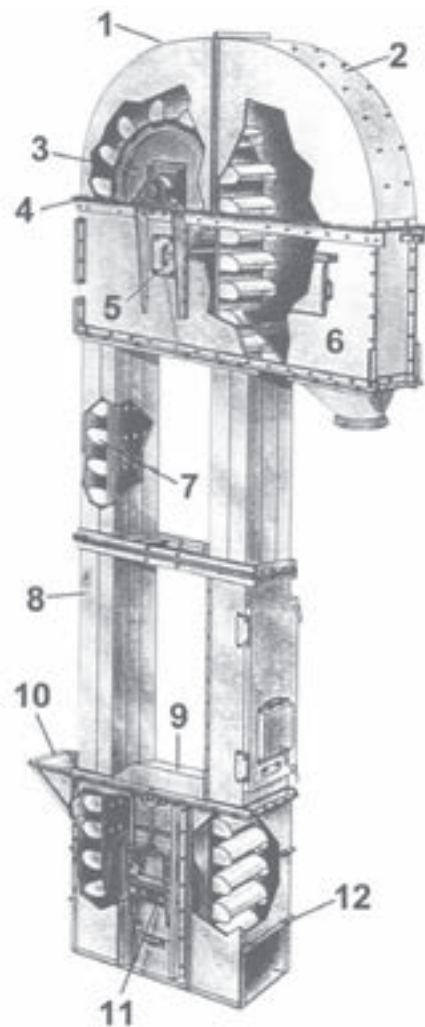

- | | |
|--|--------------------------------------|
| 1. Up-Leg Bonnet | 7. Elevator Belt & Buckets |
| 2. Down-Leg Discharge Bonnet w/ Internal Wear Liner | 8. Elevator Leg Casing & Trunking |
| 3. Head Shaft & Bearing | 9. Boot Section |
| 4. Head Section | 10. Up-Leg Inlet Hopper |
| 5. Pulley Lagging Inspection Door | 11. Boot Shaft & Take-Up Bearing |
| 6. Discharge Throat & Throat Wiper | 12. Boot Clean-Out Slide |

BUCKET ELEVATOR QUESTIONNAIRE

For More Information, Visit WWW.MAXILIFT.COM

BUCKET ELEVATOR QUESTIONNAIRE (CONT.)

- A. HEIGHT OF ELEVATOR: _____
- B. DEPTH OF LEG CASING: _____
- C. SPACING BETWEEN LEG CASING: _____
- D. HEIGHT OF LEG CASING: _____
- E. OVERALL WIDTH OF ELEVATOR: _____
- F. HEIGHT FROM HEAD SHAFT TO BONNET: _____
- G. DEPTH OF BONNET: _____
- H. WIDTH FROM HEAD SHAFT TO LEG CASING: _____
- I. DIAMETER OF DISCHARGE SPOUT: _____
- J. DISTANCE FROM HEAD SHAFT CENTERLINE DOWN TO TOP OF DISCHARGE THROAT:

- K. DISTANCE FROM HEAD SHAFT CENTERLINE DOWN TO DISCHARGE SPOUT:

- L. HEIGHT OF UP LEG INLET HOPPER: _____
- M. HEIGHT FROM BOTTOM OF ELEVATOR TO BOTTOM OF UP LEG INLET HOPPER:

- N. DEPTH OF UP LEG INLET HOPPER: _____
- O. HEIGHT OF DOWN LEG INLET HOPPER: _____
- P. HEIGHT FROM BOTTOM OF ELEVATOR TO BOTTOM OF DOWN LEG INLET HOPPER:

- Q. DEPTH OF DOWN LEG INLET HOPPER: _____
- R. HEIGHT FROM BOTTOM OF ELEVATOR TO BOOT SHAFT: _____

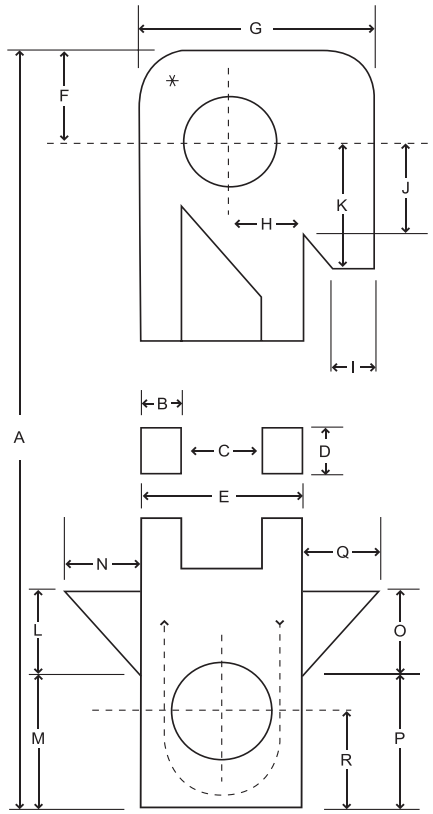

CIRCLE HEAD SHAPE:

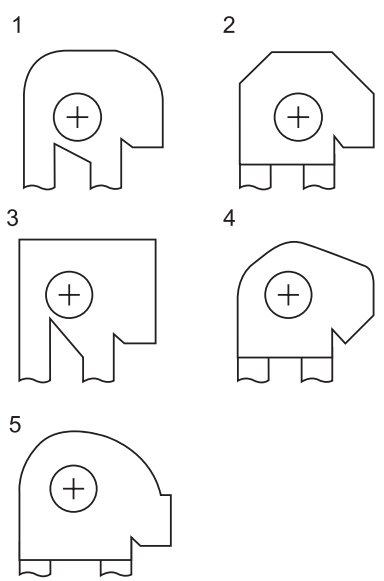

BULK MATERIAL DENSITY

For More Information, Call 1-800-527-0657

BULK MATERIAL DENSITY CHARTS

| MATERIAL DESCRIPTION | LOOSE BULK DENSITY # / CU.FT. |
|----------------------------------|-------------------------------|
| Alfalfa Meal | 14-22 |
| Alfalfa Pellets | 41-43 |
| Alfalfa Seed | 10-15 |
| Almonds, Broken | 28-30 |
| Almonds, Whole Shelled | 28-30 |
| Alum, Fine | 45-50 |
| Alum, Lumpy | 50-60 |
| Alumina Fines | 35 |
| Alumina | 50-65 |
| Alumina Sized or Briquette | 65 |
| Aluminum Chips, Oily | 7-15 |
| Aluminum Chips, Dry | 7-15 |
| Aluminum Hydrate | 13-20 |
| Aluminum Oxide | 60-120 |
| Aluminum Silicate (Andalusite) | 49 |
| Aluminum Sulfate | 45-58 |
| Aluminum Chloride, Crystalline | 45-52 |
| Aluminum Nitrate | 45-62 |
| Aluminum Sulfate | 45-58 |
| Ammonium Chloride | 45-52 |
| Ammonium Nitrate | 45 |
| Ammonium Sulfate, Granular | 45-58 |
| Ash, Black Ground | 105 |
| Ashes, Coal, Dry-1/2" | 34-35 |
| Ashes, Coal, Dry-3" & under | 35-40 |
| Ashes, Coal, Wet-1/2" | 45-50 |
| Ashes, Coal, Wet-3" & under | 45-50 |
| Asphalt Binder | 80-85 |
| Asphalt, Crushed-1/2" | 45 |
| Bakelite, Fine | 30-45 |
| Baking Powder | 40-55 |
| Baking Soda (Sodium Bicarbonate) | 40-55 |
| Barite (Barium Sulfate)+1/2" | 120-180 |
| Barite, Powder | 120-180 |
| Barium, Carbonate | 72 |
| Bark, Wood, Refuse | 10-20 |
| Barley, Fine, Ground | 24-38 |
| Barley, Malted | 31 |
| Barley, Meal | 28 |
| Barley, Scoured | 41 |
| Barley, Whole | 36-48 |
| Basalt | 80-105 |
| Bauxite, Dry, Ground | 68 |
| Bauxite, Crush-3 | 75-85 |
| Bauxite, Mine Run | 66-90 |
| Beets, Whole | 48 |
| Bentonite, Crude | 35-40 |
| Benzene Hexachloride | 56 |
| Blood, Dried | 35-45 |
| Blood, Ground | 30 |
| Bones, Whole | 35-50 |
| Bones, Crushed | 35-50 |
| Bones, Ground | 50 |
| Bonemeal | 50-60 |
| Bone Ash (Tricalcium Phosphate) | 40-50 |

| MATERIAL DESCRIPTION | LOOSE BULK DENSITY # / CU.FT. |
|--|-------------------------------|
| Borax 2"-3" Lump | 60-70 |
| Borax 1 1/2"-2" Lump | 55-60 |
| Borax Screening - 1/2" | 55-60 |
| Borax, Fine | 45-55 |
| Boric Acid, Fine | 55 |
| Boron | 75 |
| Bran, Rice-Rye Wheat | 16-20 |
| Brewer's Grain, Spent, Dry | 14-30 |
| Brewer's Grain, Spent, Wet | 55-60 |
| Brick, Hard Burned | 125 |
| Brick, Soft Burned | 100 |
| Brick, Ground 1/8" | 100-120 |
| Bronze Chips | 30-50 |
| Buckwheat | 37-42 |
| Calcine, Flour | 75-85 |
| Calcium Acetate | 125 |
| Calcium Carbide (Crushed) | 70-80 |
| Calcium Lactate | 26-29 |
| Calcium Carbonate | 90-100 |
| Calcium Oxide (See Lime, Unslaked) | 40-50 |
| Carbon, Activated, Dry, Fine | 8-20 |
| Carbon, Black, Pelleted | 20-25 |
| Carbon, Black, Powder | 4-7 |
| Carborundum | 100 |
| Cashew Nuts | 32-37 |
| Cast Iron, Chips | 130-200 |
| Caustic Soda | 88 |
| Caustic Soda, Flakes | 47 |
| Cement, Clinker | 75-95 |
| Cement, Portland | 94 |
| Cement, Aerated (Portland) | 60-75 |
| Cement, Mortar | 133 |
| Chalk, Crushed | 75-95 |
| Chalk, Pulverized | 67-75 |
| Charcoal, Lumps | 18-28 |
| Charcoal, Ground | 18-28 |
| Chips Hoggged Fuel | 15-25 |
| Chrome Ore | 125-140 |
| Cinders, Blast Furnace | 57 |
| Cinders, Coal | 40 |
| Clay, Calcined | 80-100 |
| Clay, Brick, Dry, Fines | 100-120 |
| Clay, Ceramic, Dry, Fines | 60-80 |
| Clay, Dry, Lumpy | 60-75 |
| Coal, Anthracite, Sized - 1/2" | 55-60 |
| Coal, Bituminous, Mined 50M & under | 50-54 |
| Coal, Bituminous, Mined | 40-60 |
| Coal, Bituminous, Mined, Sized | 45-55 |
| Coal, Bituminous, Mined, Run of Mine | 45-55 |
| Coal, Bituminous, Mined, Slack | 43-50 |
| Coal, Bituminous, Stripping, Not cleaned | 50-60 |
| Coal, Lignite | 40-45 |
| Coal, Char | 24 |
| Cocoa Beans | 30-40 |
| Cocoa , Nibs | 35 |

* Material density is approximate. Weight can change due to moisture content of product.

BULK MATERIAL DENSITY

For More Information, Visit WWW.MAXILIFT.COM

BULK MATERIAL DENSITY CHARTS

| MATERIAL DESCRIPTION | LOOSE BULK DENSITY # / CU.FT. |
|----------------------------------|-------------------------------|
| Cocoa, Powdered | 50 |
| Coconut, Shredded | 29 |
| Coffee, Green Bean | 45-60 |
| Coffee, Ground, Dry | 70-80 |
| Coffee, Ground, Wet | 85 |
| Coffee, Roasted Bean | 65-85 |
| Coffee, Soluble | 110-130 |
| Coke, Loose | 90-110 |
| Coke, Petroleum, Calcined | 65-75 |
| Coke, Breeze, 1/4 inch and under | 90-100 |
| Concrete, Cinder | 90-100 |
| Concrete, 2 Inch Slump | 104 |
| Concrete, 4 Inch Slump | 115 |
| Concrete, 6 Inch Slump | 85-90 |
| Concrete, In Place, Stone | 10-13 |
| Concrete, Pre-Mix, Dry | 65 |
| Copper Ore | 27-41 |
| Copper Ore, Crushed | 90-100 |
| Copper Sulfate (Bluestone) | 85-90 |
| Cork, Fine Ground | 80 |
| Cork, Granulated | 31 |
| Corn, Cracked | 80 |
| Corn Cobs, Ground | 130-180 |
| Corn Cobs, Whole | 60-65 |
| Corn, Ear | 90-100 |
| Corn Germ | 80-90 |
| Corn Grits | 70-80 |
| Corn Oil Cake | 82-85 |
| Corn, Seed | 85-95 |
| Corn, Shelled | 40-50 |
| Corn, Sugar | 45-55 |
| Cornmeal | 15-35 |
| Cottonseed Cake, Crushed | 15-25 |
| Cottonseed Cake, Lumpy | 15-50 |
| Cottonseed, Dry, Delinted | 5-15 |
| Cottonseed, Dry, Not Delinted | 20-25 |
| Cottonseed Flakes | 40-50 |
| Cottonseed Hulls | 50 |
| Cottonseed Meal, Extracted | 55-65 |
| Cottonseed Meal, Expeller | 20-35 |
| Cottonseed Meats, Dry | 75 |
| Cottonseed Meats, Rolled | 72 |
| Cracklings, Crushed | 75 |
| Cullet, Fine | 70-80 |
| Cullet, Lump | 50-60 |
| Diatomaceous Earth | 96 |
| Dicalcium Phosphate | 40-43 |
| Disodium Phosphate | 30-40 |
| Distillers' Grain, Spent, Dry | 18-25 |
| Distillers' Grain, Spent, Wet | 27-30 |
| Dolomite, Crushed | 40 |
| Dolomite, Lumpy | 40 |
| Earth, As Excavated, dry | 45-50 |
| Earth, Loam, Dry, Loose | 25-50 |
| Earth, Wet, Containing Clay | 100-150 |

| MATERIAL DESCRIPTION | LOOSE BULK DENSITY # / CU.FT. |
|-------------------------------------|-------------------------------|
| Epsom Salts | 40-50 |
| Feldspar, Ground | 65-80 |
| Feldspar, Lumps | 90-100 |
| Feldspar, Powder | 100 |
| Feldspar, Screening | 70-85 |
| Ferrous Sulfate | 60-70 |
| Ferrous Sulfide, 1/2 Inch | 120-135 |
| Ferrous Sulfide, Powder | 105-120 |
| Fish Meal | 35-40 |
| Fish Scrap | 40-50 |
| Flaxseed | 45 |
| Flaxseed Cake (Linseed Cake) | 48-50 |
| Flaxseed Meal (Linseed Meal) | 25 |
| Flour, Wheat | 35-40 |
| Flue Dust, Blast Furnace | 110-125 |
| Flue Dust, Basic Oxygen Furnace | 45-60 |
| Flue Dust, Boiler House, Dry | 35-40 |
| Fluorspar Fine (Calcium Fluoride) | 80-100 |
| Fluorspar, Lumps, 1-1/2 to 3 Inch | 90-100 |
| Fluorspar, Screenings, 1/2 Inch | 85-105 |
| Fly Ash | 30-45 |
| Foundry Refuse, Old Sand Cores, Etc | 70-100 |
| Fuller's Earth, Dry, Raw | 30-35 |
| Fuller's Earth, Oily, Spent | 60-65 |
| Fuller's Earth, Burned, Roasted | 40 |
| Glass Batch | 80-100 |
| Glue, Ground | 40 |
| Glue, Pearl | 40 |
| Glue, Vegetable, Powdered | 40 |
| Gluten Meal | 40 |
| Granite, Broken | 95-100 |
| Granite, Lumps 1-1/2-3 Inch | 85-90 |
| Granite, Screenings, 1/2 Inch | 80-90 |
| Graphite, Flake | 40 |
| Graphite Flour | 28 |
| Graphite Ore | 65-75 |
| Grass Seed | 10-12 |
| Gravel, Bank Run | 90-100 |
| Gravel, Dry, Sharp | 90-100 |
| Gravel, Pebbles | 90-100 |
| Gypsum, Calcined | 55-60 |
| Gypsum, Calcined, Powdered | 60-80 |
| Gypsum Dust, Aerated | 60-70 |
| Gypsum Dust, Non Aerated | 93 |
| Gypsum, Lumps, 1-1/2 to 3 Inch | 70-80 |
| Gypsum, Raw, 1 Inch | 70-80 |
| Gypsum, Screenings, 1/2 Inch | 70-80 |
| Guano, Dry | 70 |
| Hops, Spent, Dry | 35 |
| Hops, Spent, Wet | 50-55 |
| Iron Borings, Machine Shop | 125 |
| Iron Ore | 100-200 |
| Iron Ore, Concentrates | 120-180 |
| Iron Ore, Crushed | 135-150 |
| Iron Oxide, Pigment | 25 |

* Material density is approximate. Weight can change due to moisture content of product.

BULK MATERIAL DENSITY

For More Information, Call 1-800-527-0657

BULK MATERIAL DENSITY CHARTS

| MATERIAL DESCRIPTION | LOOSE BULK DENSITY # / CU.FT. |
|---|-------------------------------|
| Iron Oxide, Mill Scale | 75 |
| Kaffir Corn | 40-45 |
| Kaolin Clay, 3 Inch and Under | 63 |
| Kaolin Clay, Talc, 100 Mesh | 42-56 |
| Lactose | 32 |
| Lead Arsenate | 72 |
| Lead Arsenite | 72 |
| Lead Carbonate | 240-260 |
| Lead Ore, 1/8 Inch | 200-270 |
| Lead Ore, 1/2 Inch | 180-230 |
| Lead Oxide (Red Lead) 100 Mesh | 30-150 |
| Lead Oxide (Red Lead) 200 Mesh | 30-180 |
| Lead Sulfide, 100 Mesh | 240-260 |
| Lime, Ground, 1/8 Inch and Under | 60-65 |
| Lime, Hydrated, 1/8 Inch and Under | 40 |
| Lime, Hydrated, Pulverized | 32-40 |
| Lime, Pebble | 56-56 |
| Limestone, Agricultural, 1/8 Inch and Under | 68 |
| Limestone, Crushed | 85-90 |
| Limestone, Dust | 55-95 |
| Litharge, Pulverized (Lead Oxide) | 200-250 |
| Magnesium, Chloride | 33 |
| Malt, Dry Ground | 20 |
| Malt, Dry Whole | 20-30 |
| Malt, Meal | 36-40 |
| Malt, Sprouts | 13-15 |
| Malt, Wet or Green | 60-65 |
| Manganese Dioxide | 70-85 |
| Manganese Ore | 125-140 |
| Manganese Oxide | 120 |
| Manganese Sulphate | 70 |
| Marble, Crushed | 80-95 |
| Meat, Scrap with Bone | 40 |
| Mica, Flakes | 17-22 |
| Mica, Ground | 13-15 |
| Mica, Pulverized | 13-15 |
| Milk, Dried Flakes | 5-6 |
| Milk, Malted | 30-35 |
| Milk, Powdered | 20-45 |
| Milk, Whole, Powdered, Dry | 20-36 |
| Milk Sugar | 32 |
| Mill Scale | 120-125 |
| Milo | 40-45 |
| Milo, Ground | 32-36 |
| Molybdite, Powder | 107 |
| Mortar, Wet | 150 |
| Mustard Seed | 45 |
| Monosodium Phosphate | 50 |
| Niacin (Nicontinic Acid) | 35 |
| Nickel (Cobalt Sulphate Ore) | 80-150 |
| Oats | 26 |
| Oats, Crimped | 19-26 |
| Oats, Crushed | 22 |
| Oats, Rolled | 35 |
| Oat Flour | 19-24 |

| MATERIAL DESCRIPTION | LOOSE BULK DENSITY # / CU.FT. |
|------------------------------------|-------------------------------|
| Oat Hulls | 8-12 |
| Oil Cake | 45-50 |
| Orange Peel, Dry | 15 |
| Oxalic Acid, Crystals | 60 |
| Oyster Shells, Ground | 50-60 |
| Oyster Shells, Whole | 80 |
| Paper Pulp (4% or less) | 62 |
| Paper Pulp (6% to 15%) | 60-62 |
| Peanuts, Raw, Uncleaned, Unshelled | 15-20 |
| Peanuts, Clean, In Shell | 15-20 |
| Peanuts, Shelled | 35-45 |
| Peanut Meal | 30 |
| Peas, Dried | 45-50 |
| Perlite, Expanded | 8-12 |
| Perlite, Expanded, Powder | 4-12 |
| Phosphate Acid Fertilizer | 60 |
| Phosphate Rock Broken | 75-85 |
| Phosphate Rock Pulverized | 60 |
| Phosphate Sand | 90-100 |
| Phosphate, Triple Super, Ground | 50-55 |
| Polyethylene Resin, Pellets | 30-35 |
| Polystyrene Beads | 40 |
| Polyvinyl Chloride, Pellets | 20-30 |
| Polyvinyl Chloride, Powder | 20-30 |
| Potash (Muriate) Dry | 70 |
| Potash (Muriate) Mine Run | 75 |
| Potash Salt (Sylvite) | 80 |
| Potassium Carbonate | 51 |
| Potassium Chloride, Pellets | 120-130 |
| Potassium Nitrate | 76 |
| Potassium Nitrate | 80 |
| Potassium Sulfate | 42-48 |
| Potato Flour | 48 |
| Pumice, Ground | 40-45 |
| Pyrites, Iron | 135-145 |
| Pyrites, Iron, Pellets | 120-130 |
| Quartz Dust | 70-80 |
| Quartz | 80-95 |
| Rice, Hulled | 45-49 |
| Rice, Polished | 30 |
| Rice, Rough | 32-36 |
| Rice Bran | 20 |
| Rice Grits | 42-45 |
| Rice Hulls | 20-21 |
| Rubber, Reclaimed, Ground | 23-50 |
| Rubber, Reclaimed | 25-30 |
| Rubber, Pellets | 50-55 |
| Rye | 42-48 |
| Rye Feed | 33 |
| Rye Meal | 35-40 |
| Rye Middlings | 42 |
| Rye Bran | 15-20 |
| Rye, Shorts | 32-33 |
| Safflower Seed | 45 |
| Safflower Cake | 50 |

* Material density is approximate. Weight can change due to moisture content of product.

BULK MATERIAL DENSITY

For More Information, Visit WWW.MAXILIFT.COM

BULK MATERIAL DENSITY CHARTS

| MATERIAL DESCRIPTION | LOOSE BULK DENSITY # / CU.FT. |
|---------------------------------|-------------------------------|
| Safflower Meal | 50 |
| Salicylic Acid | 29 |
| Salt, Dry Coarse | 45-60 |
| Salt, Dry Fine | 70-80 |
| Salt Cake, Dry Coarse | 85 |
| Salt Cake, Dry Pulverized | 65-85 |
| Sand, Dry, Bank (Damp) | 110-130 |
| Sand, Dry, Bank (Dry) | 90-110 |
| Sand, Foundry, Prepared | 65-75 |
| Sand, Foundry (Shake Out) | 90-100 |
| Sand, Dry Silica | 90-100 |
| Sand, (Resin Coated) Silica | 104 |
| Sand, (Resin Coated) Zircon | 115 |
| Sandstone, Broken | 85-90 |
| Sawdust, Dry | 10-13 |
| Sea-Coal | 65 |
| Sesame Seed | 27-41 |
| Shale, Broken | 90-100 |
| Shale, Crushed | 85-90 |
| Shellac | 80 |
| Shellac, Powdered or Granulated | 31 |
| Silica, Flour | 80 |
| Slag, Blast Furnace, Crushed | 130-180 |
| Slag, Furnace, Granular, Dry | 60-65 |
| Slag, Furnace, Granular, Wet | 90-100 |
| Slate, Crushed, Minus 6 | 80-90 |
| Slate, Dust | 70-80 |
| Slate, Crushed, Minus 1/8 | 82-85 |
| Slate, Lump | 85-95 |
| Sludge, Sewage, Dried | 40-50 |
| Sludge, Sewage, Dry Ground | 45-55 |
| Soap, Beads or Granules | 15-35 |
| Soap, Chips | 15-25 |
| Soap, Detergent | 15-50 |
| Soap, Flakes | 5-15 |
| Soap, Powder | 20-25 |
| Soapstone, Talc, Fine | 40-50 |
| Soda Ash Briquettes | 50 |
| Soda Ash, Heavy | 55-65 |
| Soda Ash, Light | 20-35 |
| Soda Alum | 75 |
| Sodium Aluminate, Ground | 72 |
| Sodium Aluminate Sulphate | 75 |
| Sodium Nitrate | 70-80 |
| Sodium Phosphate | 50-60 |
| Sodium Sulfite | 96 |
| Soy Bean, Cake | 40-43 |
| Soy Bean, Cracked | 30-40 |
| Soy Bean, Flake, Raw | 18-25 |
| Soy Bean, Flour | 27-30 |
| Soy Bean Meal, Cold | 40 |
| Soy Bean Meal, Hot | 40 |
| Soy Beans, Whole | 45-50 |
| Starch | 25-50 |
| Steel, Turnings, Crushed | 100-150 |

| MATERIAL DESCRIPTION | LOOSE BULK DENSITY # / CU.FT. |
|---------------------------------|-------------------------------|
| Steel, Trimmings | 75-150 |
| Sugar Beet Pulp, Dry | 12-15 |
| Sugar Beet Pulp, Wet | 25-45 |
| Sugar, Refined, Granulated, Wet | 50-55 |
| Sugar, Raw | 55-65 |
| Sugar Cane, Knifed | 15-18 |
| Sulphur, Crushed Minus 1/2 | 50-60 |
| Sulphur, Lumpy Minus 3" | 80-85 |
| Sulphur, Powdered | 50-60 |
| Sunflower, Seed | 19-38 |
| Taconite, Pellets | 116-130 |
| Talcum Powder | 50-60 |
| Talcum, Minus 1/2" | 80-90 |
| Talc, Solid | 165 |
| Tallow | 58 |
| Tanbark, Ground | 55 |
| Trap Rock, Screenings | 90-100 |
| Trap Rock, Lumps | 100-110 |
| Tricalcium Phosphate | 40-50 |
| Trisodium Phosphate | 60 |
| Trisodium Phosphate, Granular | 60 |
| Trisodium Phosphate, Pulverized | 50 |
| Triple Super Phosphate | 50-55 |
| Urea Prills, Coated | 43-46 |
| Vermiculite, Ore | 80 |
| Vermiculite, Expanded | 16 |
| Vetch | 48 |
| Walnut Shells, Crushed | 35-45 |
| Wheat | 45-48 |
| Wheat Bran | 16-20 |
| Wheat, Cracked | 40-45 |
| Wheat, Flour | 33-40 |
| Wheat, Germ | 18-28 |
| Wheat, Middlings | 20-24 |
| White Lead, Dry | 75-100 |
| Wood Chips, Screened | 10-30 |
| Wood Chips, Hogged Fuel | 15-25 |
| Wood, Flour | 16-36 |
| Wood, Shavings | 8-16 |
| Zinc, Concentrate Residue | 75-80 |
| Zinc, Dust | 200 |
| Zinc, Ore, Crushed | 160 |
| Zinc, Ore, Roasted | 110 |
| Zinc Oxide, Heavy | 30-35 |
| Zinc Oxide, Light | 10 15 |

* Material density is approximate. Weight can change due to moisture content of product.

CONTACT INFORMATION

Call 1-800-527-0657 or Visit WWW.MAXILIFT.COM

CONTACT MAXI-LIFT, INC.

ONLINE AT MAXILIFT.COM

For additional information on any of our products, please visit us on the web at WWW.MAXILIFT.COM. Our complete line of literature and catalogs are available for downloading. In addition, the site contains case studies, engineering and technical information to help answer any questions. Or contact us through one of the methods below:

SOCIAL MEDIA LINKS:



<http://www.linkedin.com/company/maxi-lift-inc>
<http://www.youtube.com/user/maxiliftinc>
<https://www.facebook.com/pages/Maxi-Lift/111849878877590>
<https://twitter.com/maxiliftinc>



TELEPHONE

Phone: (972) 735-8855
Fax: (972) 735-8896
Toll Free: (800) 527-0657
(in the USA, Canada & Mexico)

MAILING ADDRESS

MAXI-LIFT, INC.
 P.O. Box 700008
 Dallas, Texas 75370-0008 USA

PHYSICAL ADDRESS:

MAXI-LIFT, INC.
 16400 Midway Road
 Addison, Texas 75001 USA

LOOKING FOR A DISTRIBUTOR IN YOUR AREA?

For a distributor in your area, please contact a Maxi-Lift sales representative at (800) 527-0657. We will ask for your phone number and zip code and give you a list of distributors in your local area.

DISCLAIMER

The information provided in this catalog may include inaccuracies or typographical errors. Changes are periodically made to the information contained in this catalog. Updated information / changes can be made at any time. Specific questions about the information contained in this catalog can be confirmed with Maxi-Lift at (800) 527-0657, (972)735-8855 or faxed to (972)735-8896.

Tolerances: Thermal plastic molded products will vary slightly in size, capacity and weight. Consult Maxi-Lift for details.

SOUTHWEST AGRI-PLASTICS, INC.

Our Sister Company

OUR SISTER COMPANY: *SOUTHWEST* **AGRI-PLASTICS**, INC.

For over three decades, Southwest Agri-Plastics has been developing new and innovative agricultural products for companies around the world. From liquid feeding wheels and mini-pallets to containers and flooring systems, our products help our customers' move, feed, and handle their products and livestock easier, faster, and more efficiently. For more information on Southwest Agri-Plastics or our products, call 1-800-288-9748 or visit us online at WWW.SWAPINC.COM.



NEW PRODUCTS FROM

MAXILIFT

Maxi-Lift Inc.®

ELEVATOR BUCKETS & BOLTS



TITAN
THE ULTIMATE BELT SPLICE

NEW MAXIMUM DUTY SPLICE!
See Page 86



MAXI-SPLICE
BELT FASTENING SYSTEMS

NEW ENHANCED DESIGN!
See Page 88



TIGER-TUFF
MAXIMUM DUTY ELEVATOR BUCKETS

NEW SMALLER SIZES!
See Page 16



800.527.0657

MAXILIFT.COM