



Falk Steelflex Grid Couplings

(Inch)

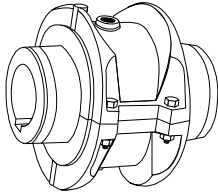

Table Of Contents

DESCRIPTION	PAGE
Falk® Steelflex® Grid Coupling Application Guide	3
How to Select	4, 5, 6
Quick Selection Method	7, 8
Service Factors	9, 10
How to Order	10
Products	10
CLOSE-COUPLED COUPLINGS	
Close-Coupled Type T10	11
Close-Coupled Type T20	12
SPACER COUPLINGS	
Full Spacer Type T31	13, 14
Half Spacer Type T35	15, 16
CONTROLLED TORQUE PRODUCTS	
Controlled Torque Types T41, T41-2	17
Controlled Torque Clutches Types T44 & T44-2	18
Piloted Controlled Torque Type T45	19
Optional Automatic Proximity Sensor Cutout Switch	20
Slip Torque Performance Charts	21, 22, 23, 24
SPECIALTY COUPLINGS	
Floating Shaft Type T50	25, 26
Caliper Disc Brake System	27
Disc Brake Type T63	28, 29
High-Speed Type T70	30
Engine Flywheel Adapter Type T90	31
Floating Shaft Type T10/G82	32
TECHNICAL DATA	
Engineering Data	33 – 42
Coupling Application Data Sheet	43

Falk Steelflex Grid Coupling Application Guide

A general purpose, lubricated design that combines the economy and high torque capacity of a gear coupling with the torsional flexibility of an elastomeric coupling. Backed by a 5-year lubrication warranty, Falk Steelflex couplings require no periodic maintenance when lubricated with Falk LTG at installation. Featuring 25 sizes, Steelflex couplings can accommodate torque loads of 8,250,000 (lb-in) and shaft diameters of 20 inches.



A double-flexing, close-coupled design for use in four-bearing systems. Features a horizontally split cover which allows for grid replacement without the movement of the connected equipment.

(See **page 11.**)

Type T10 Close-Coupled

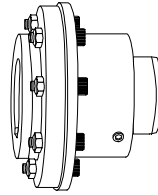

For use on line shaft applications. Can be used in place of single-engagement gear couplings to provide torsional resiliency and lower overall operating cost.

(See **pages 25 and 26.**)

Type T50 Piloted

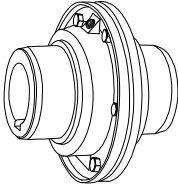

A double-flexing design featuring a vertically-split steel cover. Ideal for higher running speeds.

(See **page 12.**)

Type T20 Close-Coupled

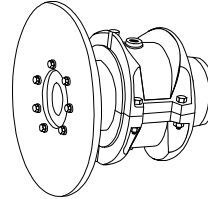

Proven to be far superior to drum-type brakes in cost, construction and performance.

(See **pages 27-29.**)

Type T63 Disc Brake

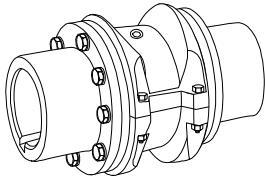

Complete center section drops out for easy service of connected equipment bearings and seals. Ideal for pump applications.

(See **pages 13 and 14.**)

Type T31 Full Spacer

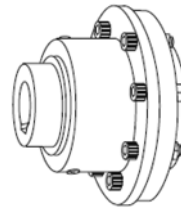

Designed for operating speeds beyond those of the T10 and T20 designs. Features a one-piece cover and balanced components.

(See **page 30.**)

Type T70 High Speed

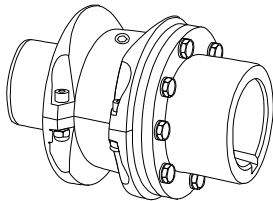

An economical spacer design for easy service of connected equipment bearings and seals. Ideal for pump applications.

(See **pages 15 and 16.**)

Type T35 Half Spacer

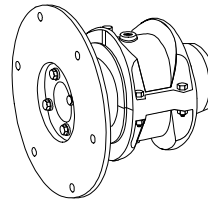

Used primarily to connect the flywheel of an engine to the driven machinery. It provides higher torque ratings with resulting smaller sizes and lower costs than elastomeric couplings.

(See **page 31.**)

Type T90 Flywheel

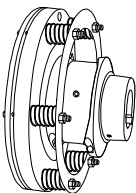

Provides adjustable slipping action to protect connected equipment from shock, jams or temporary overloads.

(See **pages 17-24.**)

Type T41/T44 Controlled Torque

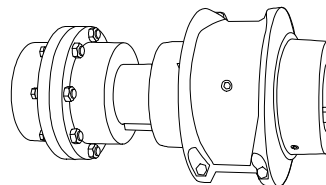

A combination of two standard Rexnord couplings. Utilizes readily available components for an economical price and shorter lead time than T31/T35 couplings.

(See **page 32.**)

Type T10/G82 Spacer

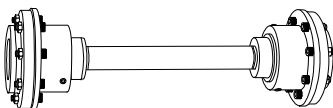

Double-piloted design for connecting equipment where the distance between shafts is too large for a spacer-type coupling.

(See **pages 25 and 26.**)

Type T50 Floating Shaft

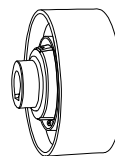

Provides a built-in breaking surface right at or near the centerline of the coupling ... saves space and dollars.

(See Selection Guide 431-310.)

Type BW Brakewheel

CAUTION! Mixing grid coupling components from *different* manufacturers may cause premature failure and possible personal injury or property damage from flying debris.

How to Select

Standard Selection Method (except T41/T44 & T63)

The standard selection method can be used for most motor, turbine or engine-driven applications. The following information is required to select a flexible coupling:

- Horsepower or torque.
- Running rpm.
- Application or type of equipment to be connected (motor to pump, gear drive to conveyor, etc.).
- Shaft diameters.
- Shaft gaps.
- Physical space limitations.
- Special bore or finish information and type of fit.

Exceptions are High Peak Loads and Brake Applications. For these conditions use the Formula Selection Method in the next column, or consult your local Rexnord representative for assistance.

1. **Rating:** Determine system torque. If torque is not given, calculate as shown below:

$$\text{System Torque (lb-in)} = \frac{\text{HP} \times 63,000}{\text{RPM}}$$

Where horsepower is the actual or transmitted power required by the application (if unknown, use the motor or turbine nameplate rating) and rpm is the actual speed the coupling is rotating. Applications that require rapid changes in direction or torque reversals should be referred to Rexnord Engineering.

2. **Service Factor:** Determine appropriate service factor from **Table 4, page 9**.
3. **Required Minimum Coupling Rating:** Determine the required minimum coupling rating as shown below:
$$\text{Minimum Coupling Rating} = \text{S.F. (Service Factor)} \times \text{Torque (lb-in)}$$
4. **Type:** Refer to **page 3** and select the appropriate coupling type.
5. **Size:** Turn to appropriate pages for the coupling type chosen and trace down the torque column to a value that is equal or greater than that determined in Step 3 above. The coupling size is shown in the first column.
6. **Check:** Check speed (rpm), bore, gap and dimensions.

Standard Selection Example:

Select a coupling to connect a 75 hp, 1750 rpm electric motor driving a lobe-type blower. Motor shaft diameter is 2.375", blower shaft diameter is 1.750". Shaft extensions are 5.375" and 4.500". Selection is replacing a gear-type coupling with a 0.125" gap.

1. **Determine Required Rating:**

$$\text{System Torque (lb-in)} = \frac{75 \text{ HP} \times 63,000}{1750 \text{ RPM}} = 2700$$

2. **Service Factor:** From **Table 4** = 1.25
3. **Required Minimum Coupling Rating:**
$$1.25 \times 2700 \text{ lb-in} = 3375 \text{ lb-in}$$
4. **Size:** From **page 11** a Size 1070T is the proper selection based on a torque rating of 8800 lb-in exceeding the required minimum coupling rating of 3375 lb-in.
5. **Check:** Allowable speed capacity of 4125 (T10) exceeds the required speed of 1750 rpm. Maximum bore capacity of 2.500" exceeds the actual shaft diameters.

Type T63 Static (Holding) Brake Applications

1. **Size:** The brake rating must equal or exceed the application requirements. Determine the required coupling size by comparing the application loads (from Steps A and B below) to the coupling brake rating listed on **page 28**. Use the highest torque value calculated to determine the coupling size.

- A. For normal service applications, use the application torque in lb-ft.

$$\text{System Torque (lb-ft)} = \frac{\text{Transmitted HP} \times 5250}{\text{RPM}}$$

- B. For repetitive high peak load applications, use the system peak torque in lb-ft. (Repetitive is defined as more than 1000 times during the expected coupling life.)

2. **Caliper Torque Brake Rating:** For the coupling size selected, compare the caliper brake torque rating on **page 28** to the holding torque requirement of the application. Rexnord recommends that the caliper torque rating (min.) be at least two times the holding torque requirement for static applications to compensate for the possibility of foreign matter on the disc surfaces, loss of condition of the brake pad surfaces, or other conditions that may affect the holding ability of the caliper brake.

Caliper brakes and brake discs listed are designed primarily for static and/or emergency brake applications. **NOTE:** Check brake system and lining wear after emergency stops. They can, however, also be used for dynamic stopping if only used occasionally, such as shutting down the equipment for the day or between shift changes. For stopping high-inertia systems or for applications that require more frequent stopping, consult your local Rexnord representative.

3. **Check:** Check maximum bores, speeds and dimensions.

Type T63 Stopping or Service Brake Applications

1. **Size:** The coupling brake rating must equal or exceed the application requirements. Determine the required coupling size by comparing the application loads (from Steps A, B and C below) to the coupling brake rating listed on **page 28**. Use the highest torque value calculated to determine the coupling size.

- A. For the selected caliper brake and disc diameter, use the maximum brake torque in lb-ft.
- B. For normal service applications, use the application torque in lb-ft.

$$\text{System Torque (lb-ft)} = \frac{\text{Transmitted HP} \times 5250}{\text{RPM}}$$

- C. For repetitive high peak load applications, use the system peak torque in lb-ft. (Repetitive is defined as more than 1000 times during the expected coupling life.)

2. **Check:** Check maximum bores, speeds and dimensions.

How to Select

Formula Selection Method (except T41/T44 & T63)

The Standard Selection Method can be used for most coupling selections. The procedures below should be used for:

- High Peak Loads.
- Brake Applications (where the brake disc or brake wheel is to be an integral part of the coupling, consult the Factory for design options).

Providing system peak torque and frequency, duty cycle and brake torque rating will allow for a more refined selection using the Formula Selection Method.

1. **High Peak Loads:** Use one of the following formulas for applications using motors with torque characteristics that are higher than normal; applications with intermittent operations, shock loading, inertia effects due to starting and stopping and/or system-induced repetitive high peak torques. System Peak Torque is the maximum torque that can exist in the system. Select a coupling with a torque rating equal to or greater than selection torque calculated below.

A. Non-Reversing High Peak Torque

$$\text{Selection Torque (lb-in)} = \text{System Peak Torque}$$

or

$$\text{System Torque (lb-in)} = \frac{\text{System Peak HP} \times 63,000}{\text{RPM}}$$

B. Reversing High Peak Torque

$$\text{Selection Torque (lb-in)} = 2 \times \text{System Peak Torque}$$

or

$$\text{System Torque (lb-in)} = \frac{2 \times \text{Peak HP} \times 63,000}{\text{RPM}}$$

- C. **Occasional Peak Torques (Non-reversing)** If a system peak torque occurs less than 1000 times during the expected coupling life, use the following formula:

$$\text{Selection Torque (lb-in)} = 0.5 \times \text{System Peak Torque}$$

or

$$\text{System Torque (lb-in)} = \frac{0.5 \times \text{Peak HP} \times 63,000}{\text{RPM}}$$

For reversing service select per step B.

2. **Brake Applications:** If the torque rating of the brake exceeds the motor torque, use the brake rating as follows:

$$\text{Selection Torque (lb-in)} = \text{Brake Torque Rating} \times \text{S.F.}$$

Formula Selection Example — High Peak Load:

Select a coupling for reversing service to connect a gear drive low-speed shaft to a runout mill table roll. The electric motor rating is 50 hp at the base speed and the system peak torque at the coupling is estimated to be 150,000 lb-in. Coupling speed is 77 rpm at the motor base speed. The drive shaft diameter is 4.000 with a keyway of 1.000" x 0.500". The runout table roll diameter is 5.250" with a keyway of 1.250" x 0.625". Maximum shaft gap is 7.00" long.

1. **Type:** Refer to **page 3** and select the appropriate coupling type.
2. **Required Minimum Coupling Rating:**
Use the Reversing High Peak Torque formula in Step 1B.
 $2 \times 150,000 = 300,000 = \text{Selection Torque}$
3. **Size:** From **page 16**, Size 1150T35 with a torque rating of 320,000 exceeds the selection torque of 300,000 lb-in.
4. **Check:** The 1150T35 has a maximum BE dimension of 7.38"; the shaft hub has a maximum bore of 10.000" with one rectangular key, (**Table 15, page 34**); the T hub bore has a maximum bore of 8.000" with one rectangular key (**Table 14, page 34**); and the allowable speed of 1500 rpm and the dimensions on **page 16**, meet the requirements.

Table 1 — Coupling Ratings & Allowable Speeds

Coupling Size ①	HP per 100 RPM ②	Torque Rating (lb-in) ③	Allowable Speeds — RPM ④			
			T10	T20 & T50 ⑤	T31, T35 & T10/G82	T70
1020T	0.73	460	4500	6000	3600	—
1030T	2.09	1,320	4500	6000	3600	10000
1040T	3.49	2,200	4500	6000	3600	—
1050T	6.11	3,850	4500	6000	3600	9000
1060T	9.60	6,050	4350	6000	3600	—
1070T	14.0	8,800	4125	5500	3600	8200
1080T	28.8	18,150	3600	4750	3600	7100
1090T	52.4	33,000	3600	4000	3600	6000
1100T	88.1	55,550	2440	3250	2440	4900
1110T	131	82,500	2250	3000	2250	4500
1120T	192	121,000	2025	2700	2025	4000
1130T	279	176,000	1800	2400	1800	3600
1140T	401	253,000	1650	2200	1650	3300
1150T	559	352,000	1500	2000	1500	—
1160T	785	495,000	1350	1750	1350	—
1170T	1,047	660,000	1225	1600	1225	—
1180T	1,452	915,200	1100	1400	1100	—
1190T	1,920	1,210,000	1050	1300	1050	—
1200T	2,618	1,650,000	900	1200	900	—
1210T	3,491	2,200,000	820	—	—	—
1220T	4,712	2,970,000	730	—	—	—
1230T	6,109	3,850,000	680	—	—	—
1240T	7,854	4,950,000	630	—	—	—
1250T	10,472	6,600,000	580	—	—	—
1260T	13,090	8,250,000	540	—	—	—

① Refer to **page 10** for General Information.

② HP per 100 RPM and torque rating values for hubs with Taper-Lock® bushings differ from those shown above. Refer to **Table 18, page 36**.

③ Peak torque capacity is two times the published rating. Torque ratings for hubs with bushings differ from those shown, refer to **Table 18, page 36**.

④ Consult Factory for higher speeds.

⑤ Speeds shown above are for single Type T50 couplings; speeds for Type T50 Floating Shaft couplings are shown in **Table 12, page 26**.

How to Select

Type T41 Controlled Torque Couplings & T44 Controlled Torque Clutches

Type T41 Controlled Torque Couplings

1. **Running Torque:** Calculate normal running torque.

$$\text{Running Torque (lb-in)} = \frac{\text{Required HP} \times 63,000}{\text{RPM}}$$

2. **Slip Torque:** Slip torque = Running Torque x 150% (Overload Setting.) Rexnord recommends a minimum 150% overload setting for steady or moderate shock load applications. For heavy shock load applications, a 200% or greater overload setting may be required.
3. **Coupling Size:** Refer to **Table 8, page 17** — Trace down the Slip Torque column to a figure equal to or in excess of the calculated slip torque determined in Step 2. Read the coupling size in the next column.

4. **Check:**

- A. Check shaft diameters against coupling maximum bores shown in **Table 8, page 17**. If selection does not have adequate bore capacity, refer to **Table 14, page 34**, or **Table 16, page 35**, for maximum bores with square or rectangular keys, or select the next larger size coupling.
- B. Check the required speed against the allowable speed shown in **Table 8**. If a higher speed is required, refer application details to the local Rexnord representative.
- C. Check allowable slip torque times from Slip Torque Performance Charts on **pages 21-24**. The length of time a coupling can slip without exceeding its thermal capacity is a function of the slip torque setting and the operating speed. An automatic cutout switch, **page 20**, can be provided when damaging thermal conditions exist.
- D. Check application dimension requirements against selected coupling dimensions shown on **page 17**.
- E. Check usable shaft length to the coupling hub lengths on **page 15**. If necessary, overhang hubs within the limits specified on **page 20**.

Selection Example

Select a controlled torque coupling to connect a 20 hp, 1750 rpm, 256T frame motor to the high-speed shaft of a gear drive driving a screw feeder. Motor shaft diameter is 1.625" with a usable shaft length of 4.000". Drive high-speed shaft diameter is 1.375" with usable shaft length of 2.500".

1. **Running Torque:** From Step 1 above:

$$\text{Running Torque (lb-in)} = \frac{20 \text{ HP} \times 63,000}{1750 \text{ RPM}} = 720 \text{ lb-in}$$

2. **Slip Torque:** From Step 2 above: Slip Torque = 720 x 150% = 1080 lb-in
3. **Size:** From **Table 8, page 17**, the Size 40T41 has a maximum slip torque of 1480 lb-in.

4. **Check:**

- A. The preferred mounting arrangement is to have the T41 hub on the motor shaft (for optimum cooling during slippage). From **Table 8, page 17**, the Size 40T41 (T41 hub) has maximum bore capacity of only 1.375" with square key and is too small; however using an optional rectangular key (**Table 16, page 35**) allows a maximum bore of 1.625" which meets the requirement. Size 40T41 has sufficient bore capacity, 1.625".
- B. Allowable Speed of 3600 rpm exceeds required 1750 rpm.
- C. From **page 21**, the Size 1040T41 with slip torque setting of 1080 lb-in and running speed of 1750 rpm will permit 23 seconds slip if followed by 7 minutes 30 seconds of non-slip.
- D. See **page 17** for dimensions.
- E. Usable shaft length of motor is 4.000" and "W" dimension for T41 hub is 3.12", therefore no overhang required. Usable shaft length of drive is 2.500" and "C" dimension of "T" hub is 2.00", therefore no overhang required.

Type T44 Controlled Torque Clutches

1. **Running Torque**

$$\text{Running Torque (lb-in)} = \frac{\text{Required HP} \times 63,000}{\text{RPM}}$$

2. **Slip Torque:** Slip Torque = Running Torque x 150% (Overload Setting.) Rexnord recommends a minimum 150% overload setting for steady or moderate shock load applications. For heavy shock load applications a 200% or greater overload setting may be required.
3. **Clutch Size:** Refer to **Table 9, page 18** — Trace down the Slip Torque column to a figure equal to or in excess of the calculated slip torque determined in Step 2. Read clutch size in the next column.
 - A. Check shaft diameters against clutch maximum bores shown in **Table 9**. If selection does not have adequate bore capacity, refer to **Table 16, page 35**, for maximum bores with square or rectangular keys, or select the next larger size clutch.
 - B. Check the required speed against the allowable speed shown in **Table 9**. If a higher speed is required, refer application details to the local Rexnord representative.
 - C. Check allowable slip torque times from Slip Torque Performance Charts on **pages 21-24**. The length of time a clutch can slip without exceeding its thermal capacity is a function of the slip torque setting and the operating speed. An automatic cutout switch, **page 20**, can be provided when damaging thermal conditions exist.
 - D. Check application dimension requirements against selected clutch dimensions shown on **page 18**.
 - E. Check usable shaft length to the clutch hub length on **page 18**. If necessary, overhang hub within the limits specified on **page 20**.

Quick Selection Method

1. Select Coupling Type.

Refer to **page 3** and select the type of coupling to suit your application. If an application requires a special purpose coupling, refer application details to the local Rexnord representative.

2. Determine Service Factor.

- A. For MOTOR, TURBINE or ENGINE driven applications, refer to **Table 4 and Table 5**.
- B. For BRAKE or HIGH PEAK LOAD applications, refer to the Formula Selection Method shown on **page 5**.

3. Determine Equivalent Horsepower.

Refer to **Table 2** — Under the actual hp required and opposite the service factor determined in Step 2, read the equivalent hp.

4. Determine Coupling Size.

- A. Refer to **Table 3** — Trace horizontally from the required speed to a hp value equal to or larger than the hp determined in Step 3. Read the coupling size at top of column.
- B. Check shaft diameters on coupling maximum bores shown in **Table 14 thru Table 17, pages 34 and 35**, for the type of coupling selected. If a larger bore is required, select a larger coupling.

Table 2 — Equivalent Horsepower = (Actual HP x Service Factor)

Service Factor ①	Actual HP																									
	3/4	1	1-1/2	2	3	5	7-1/2	10	15	20	25	30	40	50	60	75	100	125	150	200	250	300	350	400	450	500
1.00	0.75	1.0	1.5	2.0	3.0	5.0	7.5	10	15	20	25	30	40	50	60	75	100	125	150	200	250	300	350	400	450	500
1.25	0.94	1.25	1.9	2.5	3.8	6.3	9.4	12.5	19	25	31	38	50	63	75	94	125	156	188	250	312	375	438	500	563	625
1.50	1.1	1.5	2.3	3.0	4.5	7.5	11.3	15	23	30	38	45	60	75	90	113	150	188	225	300	375	450	525	600	675	750
1.75	1.3	1.8	2.6	3.5	5.3	8.8	13.1	18	26	35	44	53	70	88	105	131	175	219	262	350	438	525	613	700	787	875
2.00	1.5	2.0	3.0	4.0	6.0	10.0	15.0	20	30	40	50	60	80	100	120	150	200	250	300	400	500	600	700	800	900	1000
2.50	1.9	2.5	3.8	5.0	7.5	12.5	18.8	25	38	50	63	75	100	125	150	187	250	312	375	500	625	750	875	1000	1125	1250
3.00	2.3	3.0	4.5	6.0	9.0	15.0	22.5	30	45	60	75	90	120	150	180	225	300	375	450	600	750	900	1050	1200	1350	1500
3.50	2.6	3.5	5.3	7.0	10.5	17.5	26.2	35	52	70	87	105	140	175	210	262	350	437	525	700	875	1050	1225	1400	1575	1750

Table 3 — Coupling Selection ... Based on Equivalent HP Ratings

	1020T	1030T	1040T	1050T	1060T	1070T	1080T	1090T	1100T	1110T	1120T	1130T
Max Bore (in)	1.125	1.375	1.625	1.875	2.125	2.500	3.000	3.500	4.000	4.500	5.000	6.000
Max Speed T10	4500 RPM	4500 RPM	4500 RPM	4500 RPM	4350 RPM	4125 RPM	3600 RPM	3600 RPM	2440 RPM	2250 RPM	2025 RPM	1800 RPM
Max Speed T20	6000 RPM	6000 RPM	6000 RPM	6000 RPM	6000 RPM	5500 RPM	4750 RPM	4000 RPM	3250 RPM	3000 RPM	2700 RPM	2400 RPM
Torque (lb-in)	460	1320	2200	3850	6050	8800	18,150	33,000	55,550	82,500	121,000	176,000
HP / 100 RPM	0.73	2.09	3.49	6.11	9.60	14.0	28.8	52.4	88.1	131	192	279
RPM	HP Ratings											
4500	32.8	94.2	157	275	432 ②	628 ②	1296 ②	—	—	—	—	—
3600	26.3	75.4	126	220	346	503	1037	1885	—	—	—	—
3000	21.9	62.8	105	183	288	419	864	1571	2644 ②	3927 ②	—	—
2500	18.2	52.4	87	153	240	349	720	1309	2203 ②	3273 ②	3456 ②	—
2100	15.3	44.0	73.3	128	202	293	605	1100	1851	2749	3456 ②	5864 ②
1800	13.1	37.7	62.8	110	173	251	518	942	1587	2356	3456	5027
1750	12.8	36.7	61.1	107	168	244	504	916	1542	2291	3360	4887
1450	10.6	30.4	50.6	89	139	202	418	759	1278	1898	2784	4049
1170	8.5	24.5	40.8	71.5	112	163	337	613	1031	1532	2246	3267
1000	7.3	20.9	34.9	61.1	96	140	288	524	881	1309	1920	2793
870	6.3	18.2	30.4	53.1	84	121	251	456	767	1139	1670	2430
720	5.3	15.1	25.1	44.0	69	101	207	377	635	942	1382	2011
650	4.7	13.6	22.7	39.7	62.4	91	187	340	573	851	1248	1815
580	4.2	12.1	20.2	35.4	55.7	81	167	304	511	759	1114	1620
520	3.8	10.9	18.2	31.8	49.9	73	150	272	458	681	998	1452
420	3.1	8.8	14.7	25.7	40.3	59	121	220	370	550	806	1173
350	2.6	7.3	12.2	21.4	33.6	49	101	183	308	458	672	977
280	2.0	5.9	9.8	17.1	26.9	39.1	81	147	247	367	538	782
230	1.7	4.8	8.0	14.0	22.1	32.1	66	120	203	301	442	642
190	1.4	4.0	6.6	11.6	18.2	26.5	55	99	167	249	365	531
155	1.1	3.2	5.4	9.5	14.9	21.6	44.6	81	137	203	298	433
125	0.9	2.6	4.4	7.6	12.0	17.5	36.0	65	110	164	240	349
100	0.73	2.1	3.5	6.1	9.6	14.0	28.8	52	88	131	192	279
84	0.61	1.8	2.9	5.1	8.1	11.7	24.2	44.0	74	110	161	235
68	0.50	1.4	2.4	4.2	6.5	9.5	19.6	35.6	60	89	131	190
56	0.41	1.17	2.0	3.4	5.4	7.8	16.1	29.3	49	73	108	156
45	0.33	0.94	1.6	2.7	4.3	6.3	13.0	23.6	39.7	59	86	126
37	0.27	0.77	1.3	2.3	3.6	5.2	10.7	19.4	32.6	48.4	71	103
30	0.22	0.63	1.0	1.8	2.9	4.2	8.6	15.7	26.4	39.3	58	84
25	0.18	0.52	0.9	1.5	2.4	3.5	7.2	13.1	22.0	32.7	48.0	70
20	0.15	0.42	0.70	1.2	1.9	2.8	5.8	10.5	17.6	26.2	38.4	56
16.5	0.12	0.35	0.58	1.0	1.6	2.3	4.8	8.6	14.5	21.6	31.7	46.1
13	0.095	0.27	0.45	0.79	1.2	1.8	3.7	6.8	11.5	17.0	25.0	36.3
11	0.080	0.23	0.38	0.67	1.1	1.5	3.2	5.8	9.7	14.4	21.1	30.7
9	0.066	0.19	0.31	0.55	0.86	1.3	2.6	4.7	7.9	11.8	17.3	25.1
7.5	0.055	0.16	0.26	0.46	0.72	1.0	2.2	3.9	6.6	9.8	14.4	20.9
5	0.036	0.10	0.17	0.31	0.48	0.7	1.4	2.6	4.4	6.5	9.6	14.0

① For service factor not listed, Equivalent HP = Actual HP x Service Factor.

② Ratings apply to Type T20 only.

Quick Selection Method

- C. Check the required speed against the allowable speed shown in **Table 1** for the type of coupling selected. For Type T50 Floating Shaft design, check the allowable speed from **Table 12** on **page 26**. If a higher speed is required, refer application details to the local Rexnord representative.
- D. Check application dimension requirements against selected coupling type dimensions shown on **pages 11-32**.

Example:

Select a coupling to connect a 450 hp, 1170 rpm electric motor to the drive high-speed shaft of a maneuvering winch. The shaft gap is 0.1" to 0.2". The motor shaft diameter is 3.500" and the drive shaft diameter is 3.000". The motor and drive shaft extensions are each 6.00" long.

1. Select Coupling Type — To connect close-coupled shafts (0.1" to 0.2" gap), the Type T10 or T20 coupling is the proper selection. Type T10 is selected.
2. Determine Service Factor — From **Table 4**, the service factor is 1.5.
3. Determine Equivalent HP — From **Table 2**, the equivalent hp is 675.
4. Select Coupling Size — (A) From **Table 3**, the coupling size is 1100T. (B) From **Table 14**, the maximum bore with square key is 4.000". (C) From **Table 1**, the allowable speed of a 1100T10 is 2440 rpm. (D) Dimensions for the 1100T10 coupling shown on **page 11** satisfies the application requirements.

Table 3 — Coupling Selection ... Based on Equivalent HP Ratings (Continued)

	1140T	1150T	1160T	1170T	1180T	1190T	1200T	1210T	1220T	1230T	1240T	1250T	1260T
Max Bore (in)	7.250	8.000	9.000	10.000	11.000	12.000	13.000	14.000	15.000	16.000	17.000	18.500	20.000
Max Speed T10	1650 RPM	1500 RPM	1350 RPM	1225 RPM	1100 RPM	1050 RPM	900 RPM	820 RPM	730 RPM	680 RPM	630 RPM	580 RPM	540 RPM
Max Speed T20	2200 RPM	2000 RPM	1750 RPM	1600 RPM	—	—	—	—	—	—	—	—	—
Torque (lb-in)	253,000	352,000	495,000	660,000	915,200	1,210,000	1,650,000	2,200,000	2,970,000	3,850,000	4,950,000	6,600,000	8,250,000
HP / 100 RPM	401	559	785	1047	1452	1920	2618	3491	4712	6109	7854	10472	13090
RPM	HP Ratings												
2100	8430 ①	—	—	—	—	—	—	—	—	—	—	—	—
1800	7226 ①	10053 ①	—	—	—	—	—	—	—	—	—	—	—
1750	7025 ①	9774 ①	13745 ①	—	—	—	—	—	—	—	—	—	—
1450	5821	8098	11388 ①	15184 ①	—	—	—	—	—	—	—	—	—
1170	4697	6535	9189	12252	—	—	—	—	—	—	—	—	—
1000	4014	5585	7854	10472	14521	19199	—	—	—	—	—	—	—
870	3492	4859	6833	9111	12633	16703	22777	—	—	—	—	—	—
720	2890	4021	5655	7540	10455	13823	18850	25133	33929	—	—	—	—
650	2609	3630	5105	6807	9439	12479	17017	22689	30631	39706	—	—	—
580	2328	3239	4555	6074	8422	11135	15184	20246	27332	35430	45553	60738	—
520	2087	2904	4084	5445	7551	9983	13614	18152	24505	31765	40841	54455	68068
420	1686	2346	3299	4398	6099	8063	10996	14661	19792	25656	32987	43983	54978
350	1405	1955	2749	3665	5082	6720	9163	12217	16493	21380	27489	36652	45815
280	1124	1564	2199	2932	4066	5376	7330	9774	13195	17104	21991	29322	36652
230	923	1285	1806	2409	3340	4416	6021	8029	10839	14050	18064	24086	30107
190	763	1061	1492	1990	2759	3648	4974	6632	8954	11607	14923	19897	24871
155	622	866	1217	1623	2251	2976	4058	5411	7304	9468	12174	16232	20290
125	502	698	982	1309	1815	2400	3273	4363	5891	7636	9818	13090	16363
100	401	559	785	1047	1452	1920	2618	3491	4712	6109	7854	10472	13090
84	337	469	660	880	1220	1613	2199	2932	3958	5131	6597	8797	10996
68	273	380	534	712	987	1306	1780	2374	3204	4154	5341	7121	8901
56	225	313	440	586	813	1075	1466	1955	2639	3421	4398	5864	7330
45	181	251	353	471	653	864	1178	1571	2121	2749	3534	4712	5891
37	149	207	291	387	537	710	969	1292	1744	2260	2906	3875	4843
30	120	168	236	314	436	576	785	1047	1414	1833	2356	3142	3927
25	100	140	196	262	363	480	655	873	1178	1527	1964	2618	3273
20	80	112	157	209	290	384	524	698	942	1222	1571	2094	2618
16.5	66	92	130	173	240	317	432	576	778	1008	1296	1728	2160
13.5	54	75	106	141	196	259	353	471	636	825	1060	1414	1767
11.0	44.2	61	86	115	160	211	288	384	518	672	864	1152	1440
9.0	36.1	50	71	94	131	173	236	314	424	550	707	942	1178
7.5	30.1	42	59	79	109	144	196	262	353	458	589	785	982
5.0	20.1	27.9	39	52	73	96	131	175	236	305	393	524	655

① Ratings apply to Type T20 only.

Service Factors

Table 4 — Flexible Coupling Service Factors for Motor ① and Turbine Drives

Service factors listed are typical values based on normal operation of the drive systems.

Application	Service Factor	Application	Service Factor
AERATOR	2.0	HAMMERMILL	1.75
AGITATORS		LAUNDRY WASHER OR TUMBLER	2.0
Vertical and Horizontal		LINE SHAFTS	
Screw, Propeller, Paddle.....	1.0	Any Processing Machinery.....	1.5
BARGE HAUL PULLER	1.5	MACHINE TOOLS	
BLOWERS		Auxiliary and Traverse Drive.....	1.0
Centrifugal.....	1.0	Bending Roll, Notching Press, Punch Press,	
Lobe or Vane.....	1.25	Planer, Plate Reversing.....	1.75
CAR DUMPERS	2.5	Main Drive.....	1.5
CAR PULLERS	1.5	MAN LIFTS	Not Approved
CLARIFIER OR CLASSIFIER	1.0	METAL FORMING MACHINES	
COMPRESSORS		Continuous Caster.....	1.75
Centrifugal.....	1.0	Draw Bench Carriage and Main Drive.....	2.0
Rotary, Lobe or Vane.....	1.25	Extruder.....	2.0
Rotary, Screw.....	1.0	Farming Machine and Forming Mills.....	2.0
Reciprocating		Slitters.....	1.0
Direct Connected.....	Refer to Factory	Wire Drawing or Flattening.....	1.75
Without Flywheel.....	Refer to Factory	Wire Winder.....	1.5
② With Flywheel and Gear between Compressor		Coilers and Uncoilers.....	1.5
and Prime Mover		MIXERS (see Agitators)	
1 cylinder, single acting.....	3.0	Concrete.....	1.75
1 cylinder, double acting.....	3.0	Muller.....	1.5
2 cylinders, single acting.....	3.0	PRESS, PRINTING	1.5
2 cylinders, double acting.....	3.0	PUG MILL	1.75
3 cylinders, single acting.....	3.0	PULVERIZERS	
3 cylinders, double acting.....	2.0	Hammermill and Hog.....	1.75
4 or more cyl., single act.....	1.75	Roller.....	1.5
4 or more cyl., double act.....	1.75	PUMPS	
③ CONVEYORS		Boiler Feed.....	1.5
Apron, Assembly, Belt, Chain, Flight, Screw.....	1.0	Centrifugal — Constant Speed.....	1.0
Bucket.....	1.25	Frequent Speed Changes under Load.....	1.25
Live Roll, Shaker and Reciprocating.....	3.0	Descaling, with accumulators.....	1.25
③④ CRANES AND HOIST		Gear, Rotary, or Vane.....	1.25
Main Hoist.....	1.7 ③	Reciprocating, Plunger Piston	
Skip Hoist.....	1.75 ③	1 cyl., single or double act.....	3.0
Slope.....	1.5	2 cyl., single acting.....	2.0
Bridge, Travel or Trolley.....	1.75	2 cyl., double acting.....	1.75
DYNAMOMETER	1.0	3 or more cylinders.....	1.5
ELEVATORS		Screw Pump, Progressing Cavity.....	1.25
Bucket, Centrifugal Discharge.....	1.25	Vacuum Pump.....	1.25
Freight or Passenger.....	Not Approved	SCREENS	
Gravity Discharge.....	1.25	Air Washing.....	1.0
ESCALATORS	Not Approved	Grizzly.....	2.0
EXCITER, GENERATOR	1.0	Rotary Coal or Sand.....	1.5
EXTRUDER, PLASTIC	1.5	Vibrating.....	2.5
FANS		Water.....	1.0
Centrifugal.....	1.0	SKI TOWS & LIFTS	Not Approved
Cooling Tower.....	2.0	STEERING GEAR	1.0
Forced Draft — Across the Line start.....	1.5	STOKER	1.0
Forced Draft Motor driven thru fluid		TIRE SHREDDER	1.50
or electric slip clutch.....	1.0	TUMBLING BARREL	1.75
Gas Recirculating.....	1.5	WINCH, MANEUVERING	
Induced Draft with damper control		Dredge, Marine.....	1.5
or blade cleaner.....	1.25	WINDLASS	1.5
Induced Draft without controls.....	2.0	WOODWORKING MACHINERY	1.0
FEEDERS		WORK LIFT PLATFORMS	Not Approved
Apron, Belt, Disc, Screw.....	1.0		
Reciprocating.....	2.5		
GENERATORS			
Even Load.....	1.0		
Hoist or Railway Service.....	1.5		
Welder Load.....	2.0		

- ① For engine drives, refer to **Table 5**. Electric motors, generators, engines, compressors and other machines fitted with sleeves or straight roller bearings usually require limited end float couplings. In doubt, provide axial clearances and centering forces to the Factory for a recommendation.
- ② For balanced opposed design, refer to the Factory.
- ③ If people are occasionally transported, refer to the Factory for the selection of the proper size coupling.
- ④ For high peak load applications (such as Metal Rolling Mills) refer to the Factory.

Table 5 — Engine Drive Service Factors ⑤

Service Factors (S. F.) for engine drives are those required for applications where good flywheel regulation prevents torque fluctuations greater than ±20%. For drives where torque fluctuations are greater or where the operation is near a serious critical or torsional vibration, a mass elastic study is necessary.







No. of Cylinders	4 or 5 ⑥				6 or more ①					
	1.0	1.25	1.5	1.75	2.0	1.0	1.25	1.5	1.75	2.0
Table 4 S.F.	1.0	1.25	1.5	1.75	2.0	1.0	1.25	1.5	1.75	2.0
Engine S.F.	2.0	2.25	2.5	2.75	3.0	1.5	1.75	2.0	2.25	2.5

- ⑤ To use **Table 5**, first determine application service factor from **Table 4**. Use that factor to determine Engine Service Factor from **Table 5**. When service factor from **Table 4** is greater than 2.0, or where 1, 2 or 3 cylinder engines are involved, refer complete application details to Rexnord Engineering.

Industry	Service Factor	Industry	Service Factor
AGGREGATE PROCESSING, CEMENT, MINING KILNS; TUBE, ROD AND BALL MILLS		Shear, Croppers.....	Refer to Factory
Direct or on L. S. shaft of Reducer,		Sideguards.....	3.0
with final drive Machined Spur Gears.....	2.0	Skeip Mills.....	Refer to Factory
Single Helical or Herringbone Gears.....	1.75	Slitters, Steel Mill only.....	1.75
Conveyors, Feeders, Screens,		Soaking Pit Cover Drives —	
Elevators.....	See General Listing	Lift.....	1.0
Crushers, Ore or Stone.....	2.5	Travel.....	2.0
Dryer, Rotary.....	1.75	Straighteners.....	2.0
Grizzly.....	2.0	Unscramblers (Billet Bundle Busters).....	2.0
Hammermill or Hog.....	1.75	Wire Drawing Machinery.....	1.75
Tumbling Mill or Barrel.....	1.75	OIL INDUSTRY	
BREWING AND DISTILLING		Chiller.....	1.25
Bottle and Can Filling Machines.....	1.0	Oilwell Pumping (not over 150% peak torque).....	2.0
Brew Kettle.....	1.0	Paraffin Filter Press.....	1.5
Cookers, Continuous Duty.....	1.25	Rotary Kiln.....	2.0
Lauter Tub.....	1.5	PAPER MILLS	
Mash Tub.....	1.25	Barker Auxiliary, Hydraulic.....	2.0
Scale Hopper, Frequent Peaks.....	1.75	Barker, Mechanical.....	2.0
CLAY WORKING INDUSTRY		Barking Drum	
Brick Press, Briquette Machine, Clay Working		L. S. shaft of reducer with final drive - Helical	
Machine, Pug Mill.....	1.75	or Herringbone Gear.....	2.0
DREDGES		Machined Spur Gear.....	2.5
Cable Reel.....	1.75	Cast Tooth Spur Gear.....	3.0
Conveyors.....	1.25	Beater & Pulper.....	1.75
Cutter head, Jig Drive.....	2.0	Bleachers, Coaters.....	1.0
Maneuvering Winch.....	1.5	Calender & Super Calender.....	1.75
Pumps (uniform load).....	1.5	Chipper.....	2.5
Screen Drive, Stacker.....	1.75	Converting Machine.....	1.25
Utility Winch.....	1.5	Couch.....	1.75
FOOD INDUSTRY		Cutter, Felt Whipper.....	2.0
Beet Slicer.....	1.75	Lynder.....	1.75
Bottling, Can Filling Machine.....	1.0	Dryer.....	1.75
Cereal Cooker.....	1.25	Felt Stretcher.....	1.25
Dough Mixer, Meat Grinder.....	1.75	Fourdrinier.....	1.75
LUMBER		Jordan.....	2.0
Band Resaw.....	1.5	Log Haul.....	2.0
Circular Resaw, Cut-off.....	1.75	Line Shaft.....	1.5
Edger, Head Rig, Hog.....	2.0	Press.....	1.75
Gang Saw (Reciprocating).....	Refer to Factory	Pulp Grinder.....	1.75
Log Haul.....	2.0	Reel, Rewinder, Winder.....	1.5
Planer.....	1.75	Stock Chest, Washer, Thickener.....	1.5
Rolls, Non-Reversing.....	1.25	Stock Pumps, Centrifugal	
Rolls, Reversing.....	2.0	Constant Speed.....	1.0
Sawdust Conveyor.....	1.25	Frequent Speed Changes Under Load.....	1.25
Slab Conveyor.....	1.75	Suction Roll.....	1.75
Sorting Table.....	1.5	Vacuum Pumps.....	1.25
Trimmer.....	1.75	RUBBER INDUSTRY	
④ METAL ROLLING MILLS		Calender.....	2.0
Coilers (Up or Down) Cold Mills only.....	1.5	Cracker, Plasticator.....	2.5
Coilers (Up or Down) Hot Mills only.....	2.0	Extruder.....	1.75
Coke Plants		Intensive or Banbury Mixer.....	2.5
Pusher Ram Drive.....	2.5	Mixing Mill, Refiner or Sheeter	
Door Opener.....	2.0	One or two in line.....	2.5
Pusher or Larry Car Traction Drive.....	3.0	Three or four in line.....	2.0
Continuous Caster.....	1.75	Five or more in line.....	1.75
Cold Mills — Strip Mills.....	Refer to Factory	Tire Building Machine.....	2.5
Temper Mills.....	Refer to Factory	Tire & Tube Press Opener (Peak Torque).....	1.0
Cooling Beds.....	1.5	Tuber, Strainer, Pelletizer.....	1.75
Drawbench.....	2.0	Warming Mill	
Feed Rolls - Blooming Mills.....	3.0	One or two Mills in line.....	2.0
Furnace Pushers.....	2.0	Three or more Mills in line.....	1.75
Hot and Cold Saws.....	2.0	Washer.....	2.5
Hot Mills —		SEWAGE DISPOSAL EQUIPMENT	
Strip or Sheet Mills.....	Refer to Factory	Bar Screen, Chemical Feeders, Collectors,	
Reversing Blooming.....	Refer to Factory	Dewatering Screen, Grit Collector.....	1.0
Stabbing Mills.....	Refer to Factory	SUGAR INDUSTRY	
Edger Drives.....	Refer to Factory	Cane Carrier & Leveler.....	1.75
Ingot Cars.....	2.0	Cane Knife & Crusher.....	2.0
Manipulators.....	3.0	Mill Stands, Turbine Driver with all Helical	
Merchant Mills.....	Refer to Factory	or Herringbone gears.....	1.5
Mill Tables		Electric Drive or Steam Engine Drive with Helical,	
Roughing Breakdown Mills.....	3.0	Herringbone, or Spur Gears	
Hot Bed or Transfer, non-reversing.....	1.5	with any Prime Mover.....	1.75
Runout, reversing.....	3.0	TEXTILE INDUSTRY	
Runout, non-reversing, non-plugging.....	2.0	Batcher.....	1.25
Reel Drives.....	1.75	Calender, Card Machine.....	1.5
Rod Mills.....	Refer to Factory	Cloth Finishing Machine.....	1.5
Screwdown.....	2.0	Dry Can, Loom.....	1.5
Seamless Tube Mills		Dyeing Machinery.....	1.25
Piercer.....	3.0	Knitting Machine.....	Refer to Factory
Thrust Block.....	2.0	Mangle, Napper, Soaper.....	1.25
Tube Conveyor Rolls.....	2.0	Spinner, Tenter Frame, Winder.....	1.5
Reeler.....	2.0		
Kick Out.....	2.0		

Service Factors

SERVICE FACTORS are a guide, based on experience, of the ratio between coupling catalog rating and system characteristics. The system characteristics are best measured with a torque meter.

Torque Demands Driven Machine	Typical applications for electric motor or turbine driven equipment	Typical Service Factor
	Constant torque such as Centrifugal Pumps, Blowers and Compressors.	1.0
	Continuous duty with some torque variations including Plastic Extruders, Forced Draft Fans.	1.5
	Light shock loads from Metal Extruders, Cooling Towers, Cane Knife, Log Haul.	2.0
	Moderate shock loading as expected from a Car Dumper, Stone Crusher, Vibrating Screen.	2.5
	Heavy shock load with some negative torques from Roughing Mills, Reciprocating Pumps, Compressors, Reversing Runout Tables.	3.0
	Applications like Reciprocating Compressors with frequent torque reversals, which do not necessarily cause reverse rotations.	Refer to Factory

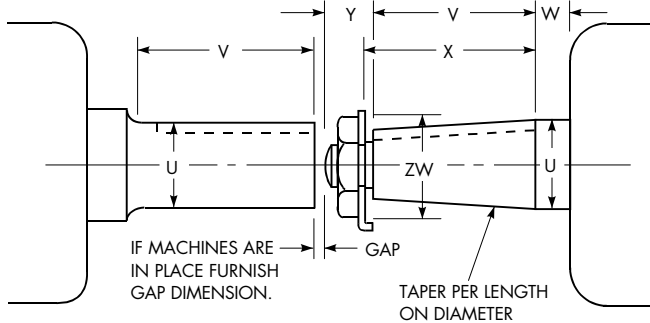

Products

General Information

- Rexnord standards apply unless otherwise specified.
- All dimensions are for reference only and are subject to change without notice unless certified.
- Unless otherwise specified, Falk coupling hub Sizes 1020 thru 1090 will be bored for clearance fit with a setscrew over the keyway. Sizes 1100 and larger will be furnished for interference fit without a setscrew (see **Table 27, page 40**). Recommended key sizes for the listed maximum bores are shown in **Table 26 on page 40**.
- Torque ratings of couplings utilizing Taper-Lock bushings can differ from those that do not. Refer to Rexnord for details.
- If Factory is to supply coupling hubs bored for Taper-Lock bushings, the bushing manufacturer **MUST** be noted on the order.
- Consult Rexnord when limited end float is required or application temperature exceeds 250°F.

How to Order

The following information is necessary to quote or ship to your exact requirements. Prompt service is assured if this information is given on your inquiry or order.

1. Application: Driver & Driven
2. Power: Normal hp, Maximum hp or Torque (lb-in)
3. Speed (rpm)
4. For Type T63 Disc Brake Couplings, furnish brake requirements.
 - A. Holding torque requirement.
 - B. WR^2 of rotating parts (at brake location).
 - C. Frequency of stops.
 - D. Rate of deceleration required — desired stop time and stopping rpm.
5. Quantity
6. Coupling Size and Type e.g., 110T41 or 1070T10
7. Shaft Gap or distance between shaft ends (BE Dimension)
8. Bore Sizes: Must specify clearance or interference fit, or fit will be furnished per **Table 27, page 40**. Bore sizes will be furnished as per **Table 28 on page 40** or **Table 30 on pages 41 and 42** unless specified differently.
9. Shaft Dimensions as follows:

For Straight Shafts:

Driving Shaft	Driven Shaft
Diameter U _____	Diameter U _____
Tolerance _____	Tolerance _____
Length V _____	Length V _____
Keyway _____	Keyway _____

NOTE: Provide shaft tolerances if different than those shown in **Table 27 through Table 30, pages 40-42**. Unless otherwise specified, keyway sizes in inch shafts will be furnished based on key sizes listed in **Table 26, page 40**, to Rexnord tolerances; metric keyways will be furnished for keys listed in **Table 26, page 40** per ISO/R773-1969 (ANSI/AGMA 9112) and Js9 width tolerances. For other shaft/bore requirements, consult Rexnord.

For Taper Shafts: keyway is assumed to be parallel to the bore.

Diameter U _____	Across Flats _____
Length V _____	Corners ZW _____
Length W _____	Taper _____
Length X _____	Keyway _____
Length Y _____	

Factory Warranty

We're so confident in the performance and reliability of our latest generation of Falk and Rexnord® gear drives that we're backing this comprehensive offering with the best standard warranty in the business. Our full, 3-year Heavy-Duty Warranty provides "shaft-to-shaft" protection on all Falk components — including bearings and seals. It's an industry first ... and one more powerful reason why Rexnord is your ultimate bottom-line drive and coupling value. ① Steelflex grid couplings are warranted for 5 Years when lubricated with Falk Long Term Grease (LTG).

- ① Warranty extends for 3 years from date of shipment. Does not apply to Falk Omnibox®, Ultramite®, Fluid Couplings, RENEW® and spare parts. Warranty applies to Steelflex and Lifelign® couplings with the use of Falk LTG.

Close-Coupled Type T10

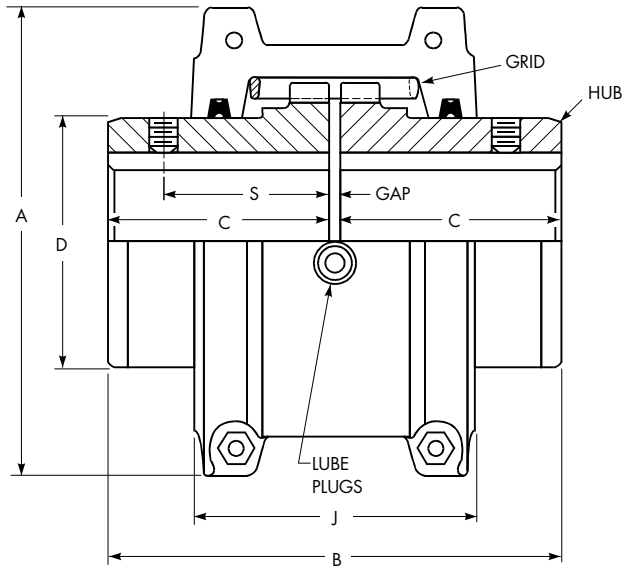

COVER PROFILES – HORIZONTAL SPLIT

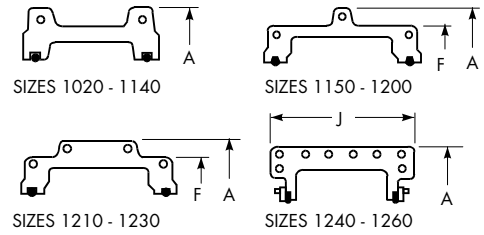

Sizes 1020 thru 1230T10 covers are cast aluminum alloy;
 Sizes 1240 thru 1260T10 are fabricated steel.

Dimensions (in)

Size ①	Torque Rating (lb-in) ②	Allow Speed RPM ③	Max Bore ④	Min Bore ⑤	Cplg Wt with No Bore (lb)	Lube Wt (lb)	A	B	C	D	F	J	S	GAP
1020T	460	4500	1.125	0.500	4.2	0.06	3.82	3.88	1.88	1.56	—	2.62	1.54	0.125
1030T	1,320	4500	1.375	0.500	5.7	0.09	4.16	3.88	1.88	1.94	—	2.69	1.54	0.125
1040T	2,200	4500	1.625	0.500	7.4	0.12	4.50	4.12	2.00	2.25	—	2.75	1.58	0.125
1050T	3,850	4500	1.875	0.500	12	0.15	5.32	4.88	2.38	2.62	—	3.19	1.76	0.125
1060T	6,050	4350	2.125	0.750	16	0.19	5.82	5.12	2.50	3.00	—	3.68	2.06	0.125
1070T	8,800	4125	2.500	0.750	23	0.25	6.25	6.12	3.00	3.44	—	3.81	2.12	0.125
1080T	18,150	3600	3.000	1.062	39	0.38	7.50	7.12	3.50	4.12	—	4.55	2.54	0.125
1090T	33,000	3600	3.500	1.062	56	0.56	8.31	7.88	3.88	4.88	—	4.81	2.82	0.125
1100T	55,550	2440	4.000	1.625	93	0.94	9.88	9.69	4.75	5.59	—	6.12	—	0.188
1110T	82,500	2250	4.500	1.625	120	1.12	10.62	10.19	5.00	6.31	—	6.36	—	0.188
1120T	121,000	2025	5.000	2.375	179	1.62	12.12	12.00	5.88	7.06	—	7.54	—	0.250
1130T	176,000	1800	6.000	2.625	266	2.0	13.62	13.00	6.38	8.56	—	7.68	—	0.250
1140T	253,000	1650	7.250	2.625	392	2.5	15.12	14.75	7.25	10.00	—	7.92	—	0.250
1150T	352,000	1500	8.000	4.250	500	4.3	17.84	14.65	7.20	10.60	15.40	10.69	—	0.250
1160T	495,000	1350	9.000	4.750	681	6.2	19.76	15.85	7.80	12.00	17.20	10.96	—	0.250
1170T	660,000	1225	10.000	5.250	987	7.7	22.32	17.25	8.50	14.00	19.18	12.10	—	0.250
1180T	915,000	1100	11.000	6.000	1365	8.3	24.80	19.05	9.40	15.50	21.84	12.64	—	0.250
1190T	1,210,000	1050	12.000	6.000	1710	9.7	26.60	20.65	10.20	17.20	23.93	12.80	—	0.250
1200T	1,650,000	900	13.000	7.000	2331	12.4	29.80	22.25	11.00	19.60	26.00	14.00	—	0.250
1210T	2,200,000	820	14.000	7.000	3140	23.2	33.25	24.50	12.00	21.00	29.56	17.00	—	0.500
1220T	2,970,000	730	15.000	8.000	3935	35.4	36.25	26.10	12.80	22.50	32.37	19.30	—	0.500
1230T	3,850,000	680	16.000	8.000	4997	53.0	39.50	27.70	13.60	24.00	35.62	21.50	—	0.500
1240T	4,950,000	630	17.000	10.000	6504	74.5	42.80	29.50	14.50	25.50	—	25.50	—	0.500
1250T	6,600,000	580	18.500	10.000	8450	110.5	46.50	32.10	15.80	28.00	—	27.50	—	0.500
1260T	8,250,000	540	20.000	10.000	10322	148.1	49.64	34.50	17.00	30.00	—	30.00	—	0.500

- ① Refer to page 10 for General Information.
- ② Peak torque capacity is two times the published rating. Torque ratings for hubs with bushings differ from those shown, refer to Table 18, page 36.
- ③ Consult Factory for higher speeds.
- ④ Maximum bores are reduced for hubs furnished with an interference fit and a setscrew over the keyway. Refer to Rexnord Engineering Sheet 427-105 for details.
- ⑤ Minimum bore is the smallest bore to which a Rough Stock Bore (RSB) hub can be bored. Depending upon coupling size, RSB hubs may have only a blind centering hole or a through hole that will permit remachining of the hubs to the minimum bores specified.

Close-Coupled Type T20

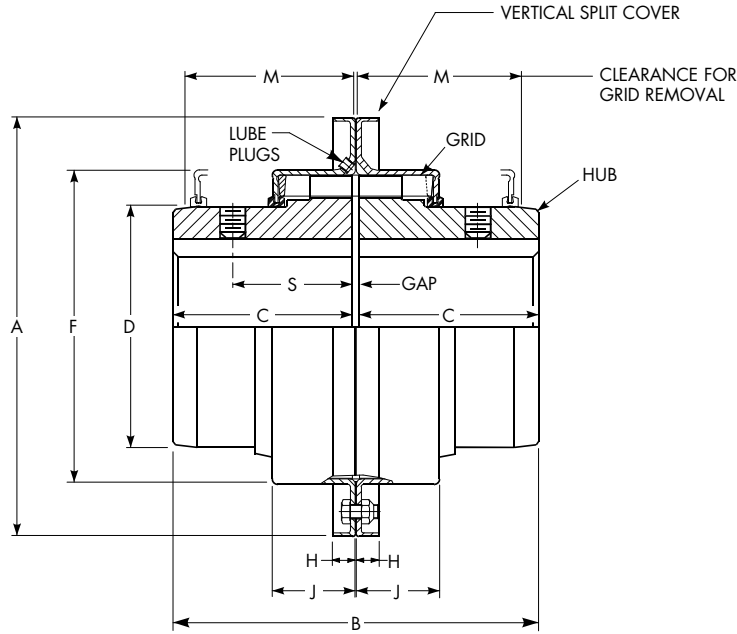

Dimensions (in)

Size ①	Torque Rating (lb-in) ③	Allow Speed RPM ④	Max Bore ⑤	Min Bore ⑥	Cplg Wt w/o Bore (lb)	Lube Wt (lb)	A	B	C	D	F	H	J	M	S	GAP
1020T	460	6000	1.125	0.500	4.3	0.06	4.42	3.88	1.88	1.56	2.50	0.38	0.94	1.88	1.54	0.125
1030T	1,320	6000	1.375	0.500	5.7	0.09	4.80	3.88	1.88	1.94	2.88	0.38	0.98	1.88	1.54	0.125
1040T	2,200	6000	1.625	0.500	7.4	0.12	5.11	4.12	2.00	2.25	3.25	0.38	1.02	2.00	1.58	0.125
1050T	3,850	6000	1.875	0.500	12	0.15	5.86	4.88	2.38	2.62	3.88	0.47	1.20	2.38	1.76	0.125
1060T	6,050	6000	2.125	0.750	15	0.19	6.42	5.12	2.50	3.00	4.38	0.50	1.25	2.50	2.06	0.125
1070T	8,800	5500	2.500	0.750	23	0.25	6.86	6.12	3.00	3.44	4.88	0.50	1.32	2.62	2.12	0.125
1080T	18,150	4750	3.000	1.062	39	0.38	7.92	7.12	3.50	4.12	5.88	0.50	1.72	3.50	2.54	0.125
1090T	33,000	4000	3.500	1.062	56	0.56	9.17	7.88	3.88	4.88	6.62	0.50	1.85	3.75	2.82	0.125
1100T	55,550	3600	4.000	1.625	93	0.94	10.55	9.69	4.75	5.59	7.75	0.62	2.35	4.75	–	0.188
1110T	82,500	3000	4.500	1.625	120	1.12	11.30	10.19	5.00	6.31	8.50	0.63	2.47	4.88	–	0.188
1120T	121,000	2700	5.000	2.375	180	1.62	12.61	12.00	5.88	7.06	9.62	0.69	2.90	5.62	–	0.250
1130T	176,000	2400	6.000	2.625	270	2.0	14.92	13.00	6.38	8.56	11.12	0.81	2.95	5.75	–	0.250
1140T	253,000	2200	7.250	2.625	397	2.5	16.42	14.75	7.25	10.00	12.62	0.81	3.08	6.12	–	0.250
1150T	352,000	2000	8.000	4.250	507	4.3	18.75	14.65	7.20	10.60	14.72	0.76 ②	4.21	8.00	–	0.250
1160T	495,000	1750	9.000	4.750	708	6.2	21.00	15.85	7.80	12.00	16.68	1.18 ②	4.50	8.50	–	0.250
1170T	660,000	1600	10.000	5.250	988	7.7	23.00	17.25	8.50	14.00	18.68	1.18 ②	4.70	8.90	–	0.250

① Refer to **page 10** for General Information.

② Dimension "H" is to the end of the bolt on Sizes 1150 thru 1170. Bolts are not shrouded.

③ Peak torque capacity is two times the published rating. Torque ratings for hubs with bushings differ from those shown, refer to **Table 18, page 36**.

④ Consult Factory for higher speeds.

⑤ Maximum bores are reduced for hubs furnished with an interference fit and a setscrew over the keyway. Refer to Rexnord Engineering Sheet 427-105 for details.

⑥ Minimum bore is the smallest bore to which a Rough Stock Bore (RSB) hub can be bored. Depending upon coupling size, RSB hubs may have only a blind centering hole or a through hole that will permit remachining of the hubs to the minimum bores specified.

Full Spacer Type T31

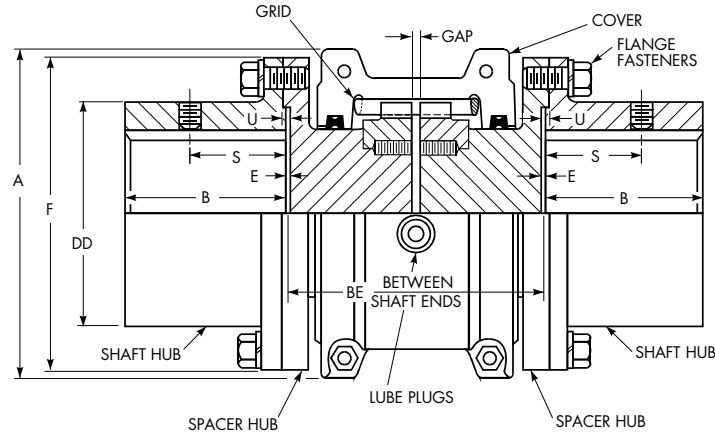

Dimensions (in)

Size ①	Torque Rating (lb-in) ②	Allow Speed RPM ③	Max Bore ④	Min Bore ⑤	Cplg Wt with No Bore & Min BE (lb)	Wt Added per Inch of BE over Min	Lube Wt (lb)	A	B	BE		DD	E	F	S	U	GAP	Flange Fasteners	
										Min	Max							No. per Flange & SAE Grade	Dia (in)
1020T	460	3600	1.375	0.500	8.5	0.57	0.06	3.82	1.38	3.50	8.00	2.06	0.03	3.38	1.08	0.08	0.188	4, Gr 8	0.250
1030T	1,320	3600	1.625	0.500	11.5	0.87	0.09	4.16	1.62	3.50	8.50	2.34	0.03	3.69	1.24	0.08	0.188	8, Gr 8	0.250
1040T	2,200	3600	2.125	0.500	18.6	1.17	0.12	4.50	2.12	3.50	8.50	3.09	0.03	4.44	1.08	0.08	0.188	8, Gr 8	0.250
1050T	3,850	3600	2.375	0.500	28.2	1.58	0.15	5.32	2.38	4.37	8.50	3.44	0.03	4.94	1.60	0.08	0.188	8, Gr 8	0.312
1060T	6,050	3600	2.875	0.750	45.1	2.06	0.19	5.82	2.88	4.81	13.00	4.06	0.06	5.69	1.70	0.11	0.188	8, Gr 8	0.375
1070T	8,800	3600	3.125	0.750	54.6	2.69	0.25	6.25	3.12	5.00	13.00	4.31	0.06	6.00	1.84	0.11	0.188	12, Gr 8	0.375
1080T	18,150	3600	3.500	1.062	88.1	3.86	0.38	7.50	3.50	6.12	16.00	4.81	0.06	7.00	1.96	0.11	0.188	12, Gr 8	0.500
1090T	33,000	3600	4.000	1.062	132	5.37	0.56	8.31	4.00	6.44	16.00	5.62	0.06	8.25	2.24	0.11	0.188	12, Gr 5	0.625
1100T	55,550	2440	4.750	1.500	199	6.95	0.94	9.88	3.56	8.00	16.00	6.75	0.06	9.88	-	0.12	0.250	12, Gr 5	0.750
1110T	82,500	2250	5.500	2.000	261	8.98	1.12	10.62	4.10	8.25	16.00	7.75	0.06	10.88	-	0.12	0.250	12, Gr 5	0.750
1120T	121,000	2025	6.250	2.500	392	11.2	1.62	12.12	4.70	9.69	16.00	8.88	0.06	12.56	-	0.16	0.375	12, Gr 5	0.875
1130T	176,000	1800	7.000	3.000	522	16.5	2.00	13.62	5.30	10.12	16.00	9.38	0.06	13.62	-	0.16	0.375	12, Gr 5	1.000
1140T	253,000	1650	8.000	3.500	720	22.4	2.50	15.12	6.00	10.50	16.00	10.50	0.06	15.19	-	0.16	0.375	12, Gr 5	1.125

- ① Refer to **page 10** for General Information.
- ② Peak torque capacity is two times the published rating. Torque ratings for hubs with bushings differ from those shown, refer to **Table 18, page 36**.
- ③ Consult Factory for higher speeds.
- ④ Maximum bores are reduced for hubs furnished with an interference fit and a setscrew over the keyway. Refer to Rexnord Engineering Sheet 427-105 for details.
- ⑤ Minimum bore is the smallest bore to which a Rough Stock Bore (RSB) hub can be bored. Depending upon coupling size, RSB hubs may have only a blind centering hole or a through hole that will permit remachining of the hubs to the minimum bores specified.

Table 6 — Type T31 Standard Stock Spacer Lengths (BE=Distance Between Shaft Ends)

Between Shaft Ends			Coupling Size										
(in)	(mm)	Pump Std	1020T	1030T	1040T	1050T	1060T	1070T	1080T	1090T	1100T	1110T	
3.50	89	ANSI	X	X	X	-	-	-	-	-	-	-	
3.94	100	ISO	X	X	X	-	-	-	-	-	-	-	
4.25	108	MISC	X	X	X	-	-	-	-	-	-	-	
4.38	111	ANSI	X	X	X	X	-	-	-	-	-	-	
4.69	119	MISC	X	X	X	X	-	-	-	-	-	-	
5.00	127	ANSI	X	X	X	X	X	X	-	-	-	-	
5.22	133	MISC	-	-	X	-	-	-	-	-	-	-	
5.38	137	MISC	-	X	X	-	-	-	-	-	-	-	
5.51	140	ISO	X	X	X	X	X	X	-	-	-	-	
5.66	144	MISC	-	X	X	-	-	-	-	-	-	-	
5.81	148	MISC	-	X	X	X	-	-	-	-	-	-	
5.97	152	MISC	-	-	X	X	-	-	-	-	-	-	
6.12	155	MISC	-	X	X	X	X	X	-	-	-	-	
6.94	176	MISC	X	X	X	X	X	-	-	-	-	-	
7.00	178	ANSI	-	-	-	-	-	X	X	-	-	-	
7.09	180	ISO	-	-	X	X	-	X	X	X	-	-	
7.25	184	ANSI	-	X	X	X	X	X	X	X	-	-	
8.00	203	MISC	-	-	-	-	-	-	-	-	X	-	
8.59	218	MISC	-	-	-	-	-	-	X	-	-	-	
8.62	219	MISC	-	-	-	-	X	X	-	-	-	-	
8.88	226	MISC	-	-	-	-	-	-	-	-	X	-	
9.75	248	ANSI	-	-	-	-	X	X	X	X	X	X	
9.84	250	ISO	-	-	-	-	-	-	-	-	X	X	
9.94	252	MISC	-	-	-	-	-	-	X	-	-	-	
11.09	282	MISC	-	-	-	-	-	-	X	-	-	-	
12.25	311	ANSI	-	-	-	-	X	X	X	X	-	-	
14.05	357	MISC	-	-	-	-	-	-	-	-	-	X	

Full Spacer Type T31

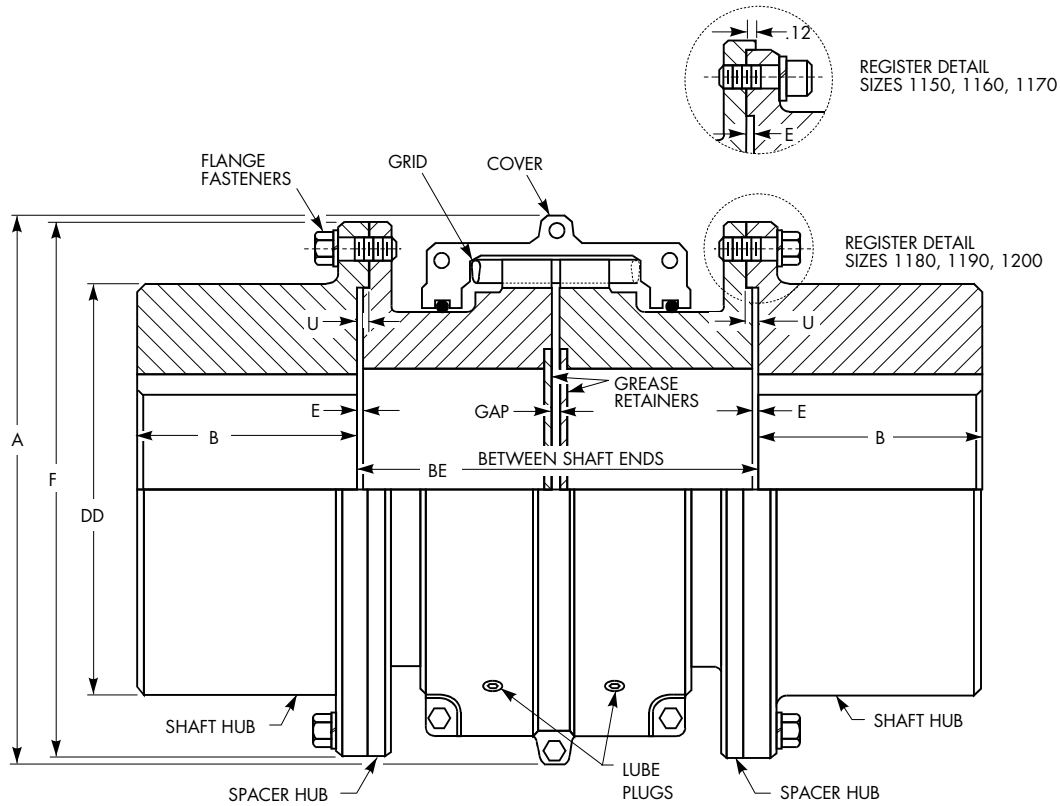

Dimensions (in)

Size ①	G52 Rigid Hub Size ③	Torque Rating (lb-in) ④	Allow Speed RPM ⑤	Max Bore ⑥	Min Bore ⑦	Cplg Wt with No Bore & Min BE (lb)	Wt Added per Inch of BE over Min	Lube Wt (lb)	A	B	BE		DD ②	E	F	U	GAP	Flange Fasteners	
											Min	Max						No. per Flange & SAE Grade	Dia (in)
1150T	1055G	352,000	1500	10.000	4.000	1018	10.8	4.3	17.84	6.80	13.56	14.62	13.16	0.20	16.75	—	0.375	14, Gr 8	0.875
1160T	1060G	495,000	1350	11.000	4.500	1247	14.0	6.2	19.74	7.34	14.00	16.00	14.41	0.26	18.00	—	0.375	14, Gr 8	0.875
1170T	1070G	660,000	1225	13.000	5.000	1887	21.3	7.7	22.30	8.67	15.13	17.50	16.73	0.33	20.75	—	0.375	16, Gr 8	1.000
1180T	1080G	915,000	1100	13.000	4.000	2502	26.5	8.3	24.80	9.80	15.75	19.31	17.75	0.20	23.25	0.32	0.375	16, Gr 5	1.125
1190T	1080G	1,210,000	1050	14.250	4.500	3362	33.8	9.7	26.60	10.86	16.19	20.88	20.00	0.20	26.00	0.32	0.375	18, Gr 5	1.250
1200T	1100G	1,650,000	900	15.000	5.000	4211	47.8	12.4	29.80	12.02	17.50	22.62	20.88	0.24	28.00	0.36	0.375	18, Gr 5	1.250

- ① Refer to **page 10** for General Information.
- ② Dimension DD is for an as-cast, unmachined surface for Sizes 1180, 1190 and 1200T.
- ③ Type T31 couplings shown use Type G52 gear coupling rigid hubs as the shaft hubs.
- ④ Peak torque capacity is two times the published rating. Torque ratings for hubs with bushings differ from those shown, refer to **Table 18, page 36**.
- ⑤ Consult Factory for higher speeds.
- ⑥ Maximum bores are reduced for hubs furnished with an interference fit and a setscrew over the keyway. Refer to Rexnord Engineering Sheet 427-105 for details.
- ⑦ Minimum bore is the smallest bore to which a Rough Stock Bore (RSB) hub can be bored. Depending upon coupling size, RSB hubs may have only a blind centering hole or a through hole that will permit remachining of the hubs to the minimum bores specified.

Half Spacer Type T35

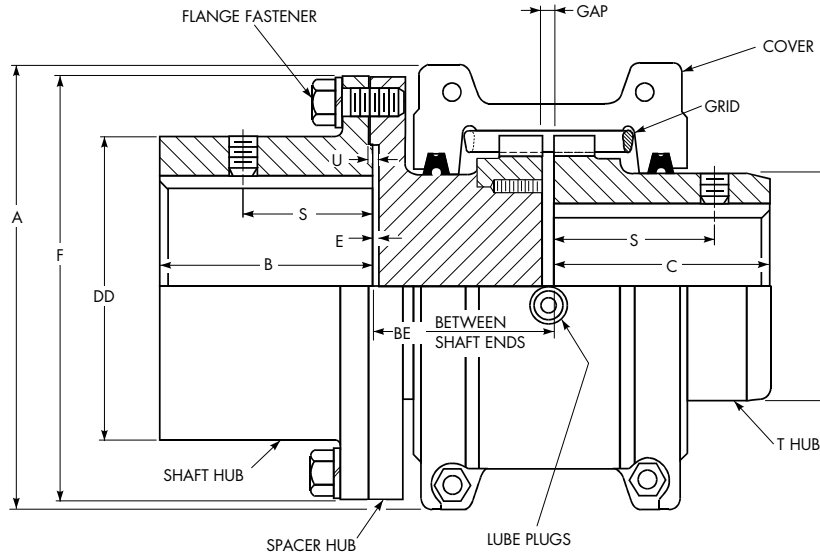

Dimensions (in)

Size ①	Torque Rating (lb-in) ④	Allow Speed RPM ⑤	Max Bore ⑥		Min Bore ⑦	Cplg Wt with No Bore & Min BE (lb)	Wt Added per Inch of BE over Min	Lube Wt (lb)	A	B	BE		C	D	DD	E	F	S			U	GAP	Flange Fasteners	
			Shaft Hub	T Hub							Min	Max						Shaft Hub	T Hub	No. per Flange & SAE Grade			Dia (in)	
1020T	460	3600	1.375	1.125	0.500	6.4	0.57	0.06	3.82	1.38	1.78	4.03	1.88	1.56	2.06	0.03	3.38	1.08	1.54	0.08	0.125	4,Gr 8	0.250	
1030T	1,320	3600	1.625	1.375	0.500	8.6	0.87	0.09	4.16	1.62	1.78	4.28	1.88	1.94	2.34	0.03	3.69	1.24	1.54	0.08	0.125	8,Gr 8	0.250	
1040T	2,200	3600	2.125	1.625	0.500	13.0	1.17	0.12	4.50	2.12	1.78	4.28	2.00	2.25	3.09	0.03	4.44	1.08	1.58	0.08	0.125	8,Gr 8	0.250	
1050T	3,850	3600	2.375	1.875	0.500	20.1	1.58	0.15	5.32	2.38	2.22	4.28	2.38	2.62	3.44	0.03	4.94	1.60	1.76	0.08	0.125	8,Gr 8	0.312	
1060T	6,050	3600	2.875	2.125	0.750	30.7	2.06	0.19	5.82	2.88	2.44	6.53	2.50	3.00	4.06	0.06	5.69	1.70	2.06	0.11	0.125	8,Gr 8	0.375	
1070T	8,800	3600	3.125	2.500	0.750	38.8	2.69	0.25	6.25	3.12	2.53	6.53	3.00	3.44	4.31	0.06	6.00	1.84	2.12	0.11	0.125	12,Gr 8	0.375	
1080T	18,150	3600	3.500	3.000	1.062	63.8	3.86	0.38	7.50	3.50	3.09	8.03	3.50	4.12	4.81	0.06	7.00	1.96	2.54	0.11	0.125	12,Gr 5	0.500	
1090T	33,000	3600	4.000	3.500	1.062	94.4	5.37	0.56	8.31	4.00	3.25	8.03	3.88	4.88	5.62	0.06	8.25	2.24	2.82	0.11	0.125	12,Gr 5	0.625	
1100T	55,550	2440	4.750	4.000	1.625 ②	146	6.95	0.94	9.88	3.56	4.06	8.06	4.75	5.59	6.75	0.06	9.88	—	—	0.12	0.188	12,Gr 5	0.750	
1110T	82,500	2250	5.500	4.500	1.625 ②	191	8.98	1.12	10.62	4.10	4.19	8.06	5.00	6.31	7.75	0.06	10.88	—	—	0.12	0.188	12,Gr 5	0.750	
1120T	121,000	2025	6.250	5.000	2.375 ②	285	11.2	1.62	12.12	4.70	4.91	8.06	5.88	7.06	8.88	0.06	12.56	—	—	0.16	0.250	12,Gr 5	0.875	
1130T	176,000	1800	7.000	6.000	2.625 ②	394	16.5	2.00	13.62	5.30	5.12	8.06	6.38	8.56	9.38	0.06	13.62	—	—	0.16	0.250	12,Gr 5	1.000	
1140T	253,000	1650	8.000	7.250	2.625 ②	556	22.4	2.50	15.12	6.00	5.31	8.06	7.25	10.00	10.50	0.06	15.19	—	—	0.16	0.250	12,Gr 5	1.125	

Table 7 — Type T35 Half Spacer Coupling Standard Stock Spacer Lengths

Between Shaft Ends		Pump Std	Coupling Size ③									
(in)	(mm)		1020T	1030T	1040T	1050T	1060T	1070T	1080T	1090T	1100T	1110T
1.78	45	MISC	X	X	X	—	—	—	—	—	—	—
2.22	56	MISC	X	X	X	X	—	—	—	—	—	—
2.53	64	MISC	X	X	X	X	X	X	—	—	—	—
2.79	71	MISC	X	X	X	X	X	X	—	—	—	—
3.50	89	ANSI	X	X	X	X	X	—	—	—	—	—
3.53	90	MISC	—	—	—	—	—	X	X	—	—	—
3.66	93	MISC	—	X	X	X	X	X	X	X	—	—
3.58	91	MISC	—	—	—	—	—	X	X	X	—	—
4.06	103	MISC	—	—	—	—	—	—	—	—	X	—
4.94	125	MISC	—	—	—	—	—	—	—	—	X	X
5.00	127	ANSI	—	—	—	—	—	—	—	X	X	X
5.51	140	ISO	—	—	—	—	—	—	X	X	X	—
6.16	156	MISC	—	—	—	—	X	X	X	X	—	—
6.19	157	MISC	—	—	—	—	—	—	—	—	X	—
7.09	180	ISO	—	—	—	—	—	—	—	X	—	X

- ① Refer to page 10 for General Information.
- ② Minimum bores are for the T Hub. Shaft hub bores are 1.500, 2.000, 2.500 and 3.500, respectively.
- ③ **CAUTION:** To permit removal of T35 shaft hub without moving connected equipment, select a half spacer with dimension BE (in Table 7) greater than dimension B (in uppermost table) or overhang the shaft hub. Refer to Falk for maximum overhang allowed.
- ④ Peak torque capacity is two times the published rating. Torque ratings for hubs with bushings differ from those shown, refer to Table 18, page 36.
- ⑤ Consult Factory for higher speeds.
- ⑥ Maximum bores are reduced for hubs furnished with an interference fit and a setscrew over the keyway. Refer to Rexnord Engineering Sheet 427-105 for details.
- ⑦ Minimum bore is the smallest bore to which a Rough Stock Bore (RSB) hub can be bored. Depending upon coupling size, RSB hubs may have only a blind centering hole or a through hole that will permit remachining of the hubs to the minimum bores specified.

Half Spacer Type T35

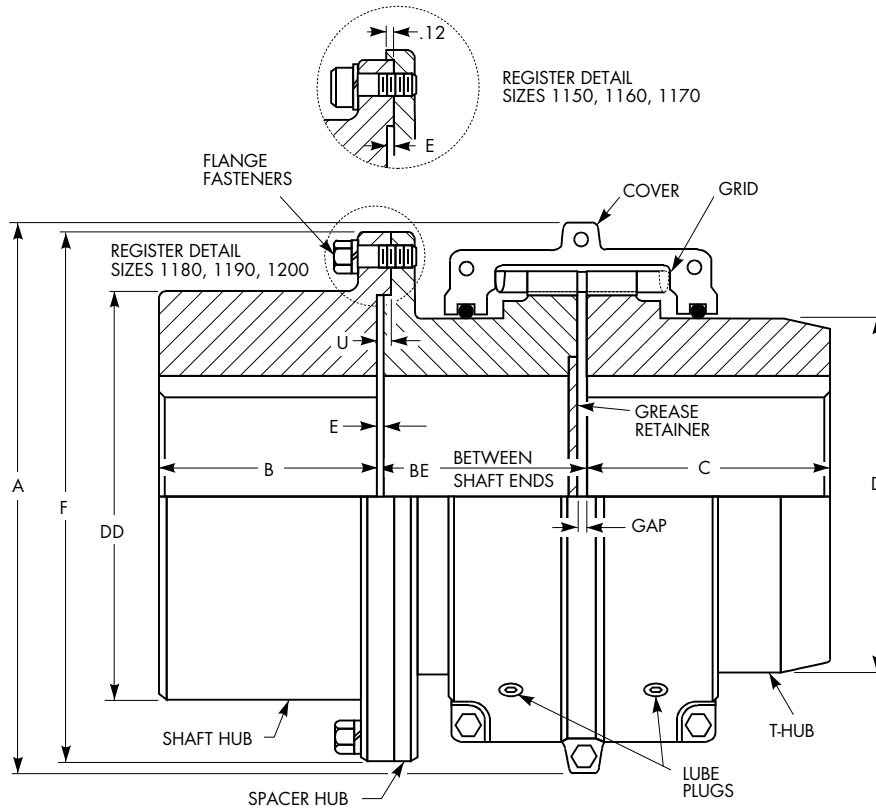

Dimensions (in)

Size ①	G52 Rigid Hub Size ③	Torque Rating (lb-in) ④	Allow Speed RPM ⑤	Hub Bores				Cplg Wt with No Bore & Min BE (lb)	Wt Added per Inch of BE over Min	Lube Wt (lb)	A	B	BE		C	D	DD ^②	E	F	U	GAP	Flange Fasteners	
				Shaft Hub ③		T Hub							Min	Max								No. per Flange & SAE Grade	Dia (in)
				Max ^⑥	Min ^⑦	Max ^⑥	Min ^⑦																
1150T	1055G	352,000	1500	10.000	4.000	8.000	4.250	767	10.8	4.3	17.84	6.80	6.87	7.38	7.20	10.60	13.16	0.20	16.75	—	0.250	14,Gr 8	0.875
1160T	1060G	495,000	1350	11.000	4.500	9.000	4.750	973	14.0	6.2	19.74	7.34	7.07	8.06	7.80	12.00	14.41	0.26	18.00	—	0.250	14,Gr 8	0.875
1170T	1070G	660,000	1225	13.000	5.000	10.000	5.250	1437	21.3	7.7	22.30	8.67	7.64	8.81	8.50	14.00	16.73	0.33	20.75	—	0.250	16,Gr 8	1.000
1180T	1080G	915,000	1100	13.000	4.000	11.000	6.000	1934	26.5	8.3	24.80	9.80	7.94	9.72	9.40	15.50	17.75	0.20	23.25	0.32	0.250	16,Gr 5	1.125
1190T	1090G	1,210,000	1050	14.250	4.500	12.000	6.000	2536	33.8	9.7	26.60	10.86	8.16	10.50	10.20	17.20	20.00	0.20	26.00	0.32	0.250	18,Gr 5	1.250
1200T	1100G	1,650,000	900	15.000	5.000	13.000	7.000	3271	47.8	12.4	29.80	12.02	8.81	11.38	11.00	19.60	20.88	0.24	28.00	0.36	0.250	18,Gr 5	1.250

- ① Refer to **page 10** for General Information.
- ② Dimension DD is for an as-cast, unmachined surface for Sizes 1180, 1190 and 1200T.
- ③ Type T35 couplings shown use Type G52 gear coupling rigid hubs as the shaft hubs.
- ④ Peak torque capacity is two times the published rating. Torque ratings for hubs with bushings differ from those shown, refer to **Table 18, page 36**.
- ⑤ Consult Factory for higher speeds.
- ⑥ Maximum bores are reduced for hubs furnished with an interference fit and a setscrew over the keyway. Refer to Rexnord Engineering Sheet 427-105 for details.
- ⑦ Minimum bore is the smallest bore to which a Rough Stock Bore (RSB) hub can be bored. Depending upon coupling size, RSB hubs may have only a blind centering hole or a through hole that will permit remachining of the hubs to the minimum bores specified.

Controlled Torque Types T41, T41-2

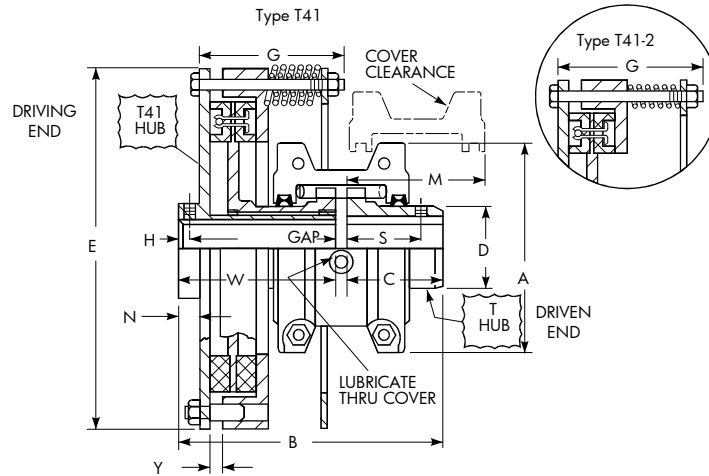

Dimensions (in)

Size ①	Cplg Wt w/o Bore (lb) ②		Lube Wt (lb)	A	B	C	D	E	G	H	M ④	N	S	W	Y ⑤	GAP
	T41	T41-2														
1020T	13.6	—	0.06	3.82	5.12	1.88	1.56	7.00	2.50	0.22	1.88	0.42	1.54	3.12	0.20	0.125
1030T	18.0	18.0	0.09	4.16	5.12	1.88	1.94	7.94	2.74	0.22	2.00	0.42	1.54	3.12	0.20	0.125
1040T	25.4	24.9	0.12	4.50	5.24	2.00	2.24	9.12	3.24	0.22	2.50	0.48	1.58	3.12	0.20	0.125
1050T	36.2	35.2	0.15	5.32	5.94	2.38	2.62	10.64	3.24 ③	0.22	2.50	0.42	1.76	3.44	0.20	0.125
1060T	48.4	46.9	0.19	5.82	6.42	2.50	3.00	11.86	3.50	0.32	3.00	0.60	2.06	3.80	0.20	0.125
1070T	62.2	60.2	0.25	6.25	7.20	3.00	3.44	12.74	4.00	0.32	3.26	0.58	2.12	4.08	0.20	0.125
1080T	90.4	88.9	0.38	7.50	8.12	3.50	4.12	14.24	4.00	0.32	3.62	0.58	2.54	4.50	0.20	0.125
1090T	138	133	0.56	8.31	9.06	3.88	4.88	16.28	5.00	0.32	4.30	0.64	2.80	5.06	0.20	0.125
1100T	222	202	0.94	9.88	10.60	4.75	5.60	19.34	5.50	—	5.80	0.82	—	5.66	0.20	0.188
1110T	282	267	1.1	10.62	11.35	5.00	6.32	21.38	6.00	—	6.00	0.86	—	6.16	0.36	0.188
1120T	403	383	1.6	12.12	13.43	5.88	7.06	23.24	7.00	—	7.00	1.06	—	7.30	0.36	0.250
1130T	573	548	2.0	13.62	14.21	6.38	8.56	26.92	7.50	—	7.30	1.06	—	7.58	0.36	0.250
1140T	828	793	2.5	15.12	15.32	7.25	10.00	30.18	8.00	—	8.40	1.07	—	7.82	0.36	0.250
1150T	1106	—	4.2	17.84	17.11	7.20	10.60	34.00	8.50	—	10.00	1.25	—	9.66	0.36	0.250
1160T	1437	—	6.2	19.76	17.91	7.80	12.00	38.92	8.50	—	10.00	1.27	—	9.86	0.36	0.250
1170T	1916	—	7.7	22.32	19.29	8.50	14.00	41.96	9.50	—	10.50	1.27	—	10.54	0.36	0.250
1180T	2560	—	8.3	24.80	21.13	9.40	15.50	45.70	9.50	—	10.50	1.68	—	11.48	0.36	0.250
1190T	3143	—	9.7	26.60	22.15	10.20	17.20	49.76	10.00	—	11.00	1.68	—	11.70	0.36	0.250
1200T	3980	—	12.4	29.80	23.67	11.00	19.60	54.22	10.00	—	11.00	1.68	—	12.42	0.36	0.250

- ① Refer to page 10 for General Information. Use a coupling guard that will permit air to circulate and cool the coupling.
- ② Weights are for couplings with Dimension C and W length hubs.
- ③ Dimension shown is for Type T41. Type T41-2 = 3.50.
- ④ To remove cover without disturbing torque setting, allow M clearance.
- ⑤ With new friction segments.
- ⑥ Refer to Table 14 and Table 16 for maximum bores with square or rectangular keys.

Table 8 — T41 Slip Torques, Bores & Speeds

Slip Torque (lb-in)		Coupling Size	Maximum Bore with Recommended Keys ⑥		Allow Speed RPM
Min	Max		T41 Hub	T Hub	
42	336	1020T41	1.000	1.125	3600
50	140	1030T41-2	1.250	1.375	3600
110	880	1030T41			
60	230	1040T41-2	1.375	1.625	3600
185	1,480	1040T41			
80	370	1050T41-2	1.750	1.875	3600
300	2,400	1050T41			
100	650	1060T41-2	1.875	2.125	3600
520	4,160	1060T41			
120	960	1070T41-2	2.250	2.500	3600
770	6,160	1070T41			
390	1,700	1080T41-2	2.625	3.000	2800
1,350	10,800	1080T41			
660	2,800	1090T41-2	3.125	3.500	2500
2,250	18,000	1090T41			
1,200	5,100	1100T41-2	3.625	4.000	2100
4,100	32,800	1100T41			
1,800	7,600	1110T41-2	4.000	4.500	1850
6,100	48,800	1110T41			
2,600	11,400	1120T41-2	4.500	5.000	1750
9,100	72,800	1120T41			
3,800	16,200	1130T41-2	5.250	6.000	1450
13,000	104,000	1130T41			
5,400	23,000	1140T41-2	6.500	7.250	1300
18,400	147,200	1140T41			
26,000	208,000	1150T41	7.000	8.000	1100
36,000	288,000	1160T41	8.500	9.000	950
49,000	392,000	1170T41	9.500	10.000	870
67,000	536,000	1180T41	11.000	11.000	760
90,000	720,000	1190T41	12.000	12.000	720
120,000	960,000	1200T41	13.000	13.000	670

Controlled Torque Clutches Types T44 & T44-2

Figure A — Sprocket Mounted (not included) — See Sprocket Selections **Table 10**.

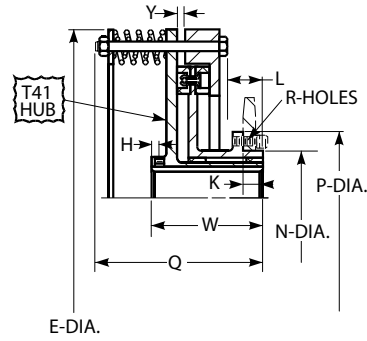

Dimensions (in)

Size ①	Cplg Wt ^② w/o Bore (lb)		E	H	K	L	N +.000 -.001	P	Q	R			W	Y ^③	Max Chain Size
	T44	T44-2								Size (UNC)	No.	Bolt Circle Dia			
1020T	11.6	—	7.00	0.22	0.780	1.00	1.750	2.400	3.84	10-24	4	2.100	3.12	0.20	40
1030T	14.3	14.3	7.94	0.22	0.730	1.00	2.250	3.000	4.10	10-24	6	2.600	3.12	0.20	50
1040T	18.9	18.4	9.12	0.22	0.530	0.88	2.625	3.600	4.46	0.250-20	6	3.100	3.12	0.20	60
1050T	29.4	28.4	10.64	0.22	0.750	1.20	3.000	4.200	4.78	0.312-18	6	3.600	3.44	0.20	80
1060T	35.2	33.7	11.86	0.32	0.790	1.36	3.500	4.900	5.18	0.375-16	6	4.200	3.80	0.20	100
1070T	45.2	43.2	12.74	0.32	0.970	1.54	4.000	5.400	5.92	0.375-16	8	4.700	4.08	0.20	100
1080T	63.0	60.5	14.24	0.32	1.210	1.96	4.750	6.300	6.34	0.438-14	8	5.500	4.50	0.20	140
1090T	97.5	92.5	16.28	0.32	1.350	2.22	5.500	7.300	7.66	0.500-13	8	6.400	5.06	0.20	160
1100T	167	157	19.34	—	1.270	2.32	6.250	8.500	8.40	0.625-11	8	7.300	5.66	0.20	180
1110T	232	217	21.38	—	1.480	2.52	6.750	9.400	9.10	0.750-10	8	8.000	6.16	0.36	180
1120T	288	268	23.24	—	2.160	3.34	7.625	10.300	10.98	0.750-10	10	8.900	7.30	0.36	200
1130T	452	427	26.92	—	2.160	3.38	9.250	11.900	11.52	0.750-10	12	10.500	7.56	0.36	200
1140T	637	602	30.18	—	2.160	3.24	11.000	13.700	11.88	0.750-10	14	12.300	7.82	0.36	200

Figure B — Sheave Mounted (not included) — See Minimum Sheave Selections **Table 11**.

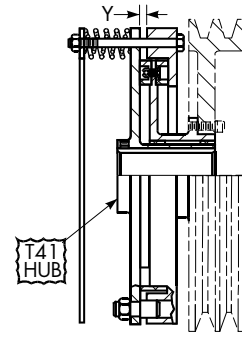

Table 9 — T44 Slip Torques, Bores & Speeds

Slip Torque (lb-in)		Clutch Size	Maximum Bore with Recommended Keys ^④	Allow Speed RPM
Min	Max			
42	336	1020T44	1.000	3600
50	140	1030T44-2	1.250	3600
110	880	1030T44	1.250	3600
60	230	1040T44-2	1.375	3600
185	1,480	1040T44	1.375	3600
80	370	1050T44-2	1.750	3600
300	2,400	1050T44	1.750	3600
100	650	1060T44-2	1.875	3600
520	4,160	1060T44	1.875	3600
120	960	1070T44-2	2.250	3600
770	6,160	1070T44	2.250	3600
390	1,700	1080T44-2	2.625	2800
1,350	10,800	1080T44	2.625	2800
660	2,800	1090T44-2	3.125	2500
2,250	18,000	1090T44	3.125	2500
1,200	5,100	1100T44-2	3.625	2100
4,100	32,800	1100T44	3.625	2100
1,800	7,600	1110T44-2	4.000	1850
6,100	48,800	1110T44	4.000	1850
2,600	11,400	1120T44-2	4.500	1750
9,100	72,800	1120T44	4.500	1750
3,800	16,200	1130T44-2	5.250	1450
13,000	104,000	1130T44	5.250	1450
5,400	23,000	1140T44-2	6.500	1300
18,400	147,200	1140T44	6.500	1300

Table 10 — Sprocket Selections^⑤ (Minimum Number of Teeth) — (See Figure A)

Chain Size	Clutch Size												
	1020	1030	1040	1050	1060	1070	1080	1090	1100	1110	1120	1130	1140
35	24	29	—	—	—	—	—	—	—	—	—	—	—
40	19	23	27	30	—	—	—	—	—	—	—	—	—
50	—	19	22	25	29	31	—	—	—	—	—	—	—
60	—	—	19	22	24	26	30	—	—	—	—	—	—
80	—	—	—	17	19	21	24	27	31	—	—	—	—
100	—	—	—	—	16	17	20	22	25	27	30	—	—
120	—	—	—	—	—	—	17	19	22	24	25	29	—
140	—	—	—	—	—	—	15	17	19	21	22	25	28
160	—	—	—	—	—	—	—	15	17	19	20	23	25
180	—	—	—	—	—	—	—	—	16	17	18	20	23
200	—	—	—	—	—	—	—	—	—	—	17	19	21

Table 11 — Minimum Sheave Selections^⑥ (See Figure B)

Size	Belt Type							
	Outside Diameter			Pitch Diameter				
	3V	5V	8V	A	B	C	D	E
1020T	3.10	7.10	12.50	3.13	5.40	9.00	13.00	21.00
1030T	3.70	7.10	12.50	3.73	5.40	9.00	13.00	21.00
1040T	4.30	7.10	12.50	4.33	5.40	9.00	13.00	21.00
1050T	4.90	7.10	12.50	4.93	5.40	9.00	13.00	21.00
1060T	5.60	7.10	12.50	5.63	5.71	9.00	13.00	21.00
1070T	6.10	7.10	12.50	6.13	6.21	9.00	13.00	21.00
1080T	7.00	7.50	12.50	7.03	7.11	9.00	13.00	21.00
1090T	8.00	8.50	12.50	8.03	8.11	9.00	13.00	21.00
1100T	9.20	9.70	12.50	9.23	9.31	9.66	13.00	21.00
1110T	10.10	10.60	12.50	10.13	10.21	10.56	13.00	21.00
1120T	11.00	11.50	12.50	11.03	11.11	11.46	13.00	21.00
1130T	12.60	13.10	13.90	12.63	12.71	13.06	13.40	21.00
1140T	14.40	14.90	15.70	14.43	14.51	14.86	15.20	21.00

- ① Refer to page 10 for General Information.
- ② Weights are for couplings with Dimension W length hubs.
- ③ With new friction segments.
- ④ Refer to Table 16 for maximum bores with square or rectangular keys.
- ⑤ Based on minimum clearance for sprocket chain over "P" diameter.
- ⑥ Based on mounting flange restrictions.

Piloted Controlled Torque Type T45

Piloted Controlled Torque Assemblies

A T45 coupling is a hybrid T41/T50 assembly. It provides the shock-dampening of a Steelflex grid coupling in a piloted design for floating shafts with a controlled torque feature for overload protection.

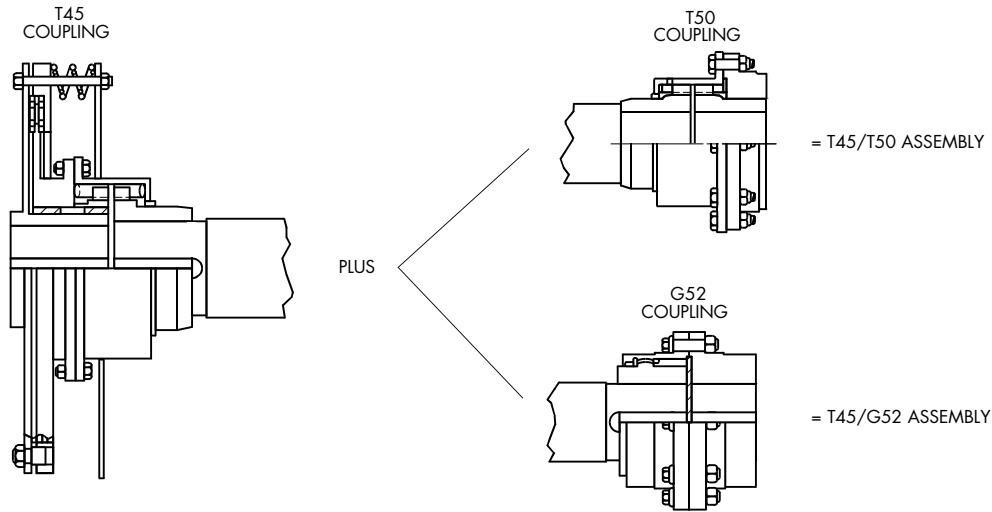

A T42 coupling is also a hybrid. It is a T41 controlled torque assembly mated to a standard flex half gear coupling. This arrangement provides for high torques and a torsionally stiffer assembly with overload protection.

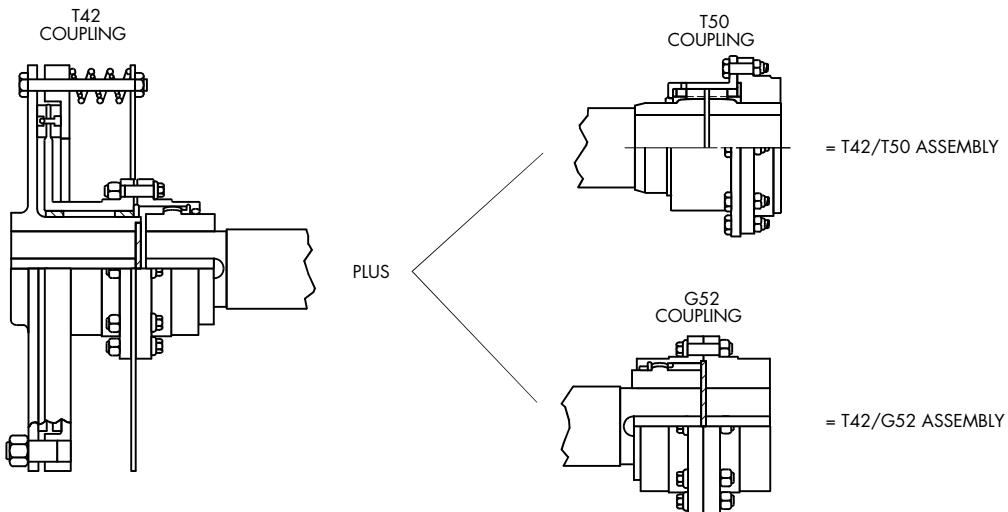

Either the T45 or T42 coupling can be used with a T50 or G52 coupling on the opposite end of the floating shaft to achieve different operational characteristics or preferences for grid or gear couplings.

Contact Rexnord's Coupling Inquiry Department or Coupling Engineering for selection assistance.

T42 Flex Half Selection

T42 Control Coupling Size	G52 Flex Half Coupling Size
1030T42	1010G
1040T42	1010G
1050T42	1010G
1060T42	1015G
1070T42	1015G
1080T42	1020G
1090T42	1025G
1100T42	1030G

T42 Flex Half Selection

T42 Control Coupling Size	G52 Flex Half Coupling Size
1110T42	1030G
1120T42	1035G
1130T42	1040G
1140T42	1050G
1150T42	1050G
1160T42	1060G
1170T42	1070G

Optional Automatic Proximity Sensor Cutout Switch

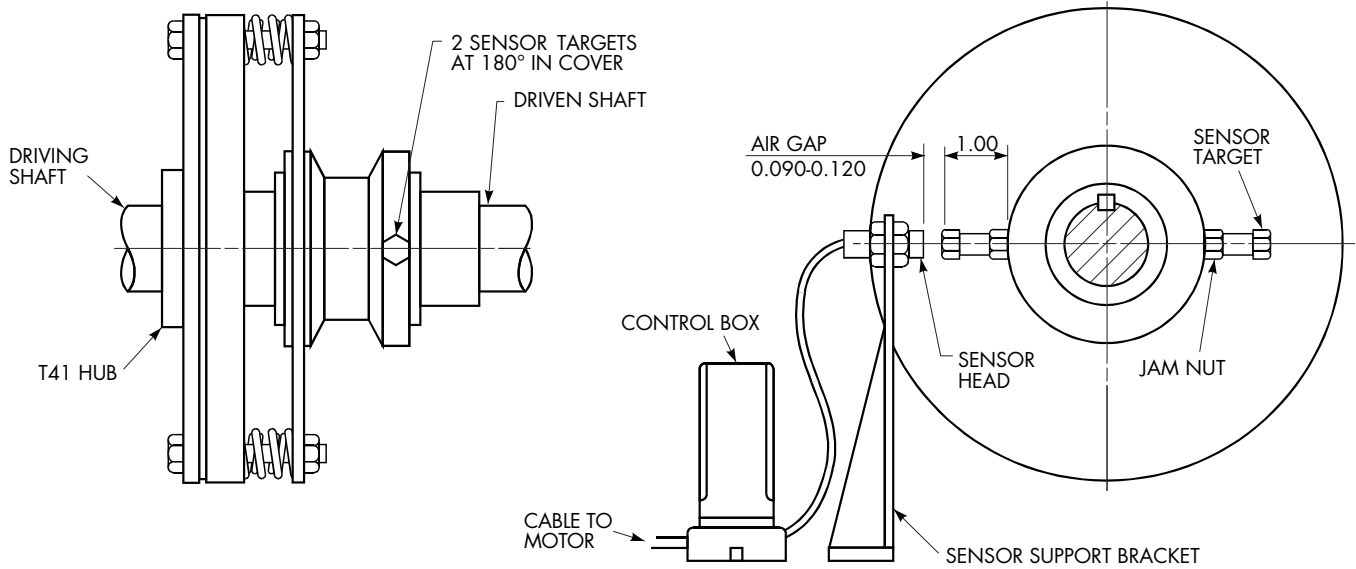

An automatic proximity cutout switch in the motor starter control circuit of controlled torque coupling or clutch application is recommended for protection of connected equipment and coupling or clutch where damaging thermal buildup could develop. Refer to Slip Torque Performance Charts on **pages 21-24** to determine if an automatic proximity sensor cutout switch is required.

The proximity cutout switch speed control is adjustable at the control box. It is set at a required cutout speed and continually compares the actual speed of the driven shaft with the set cutout speed. The control box can be mounted in an approximate space of 3 inches wide by 3 inches deep by 5 inches high.

During overload, the coupling or clutch slips at a predetermined speed. When the driven shaft speed drops below the cutout switch speed setting, it opens the motor circuit and the drag load stops the motor shaft.

When the underspeed cutout switch is wired for automatic reset, the drive is immediately ready for service (after overload is removed) without resetting the circuit at any point. To restart the drive, just press either the main or remote control start button. The motor will not maintain normal operation if the overload has not been removed because the motor contractor circuit will reopen as soon as the start button is released.

The customer may incorporate a warning light or an alarm to the circuit to signal the operator of an overload or shutdown condition.

Refer to Service Manual 428-440 for complete details.

Overhanging Hubs

When the distance between shaft ends is greater than the coupling gap or when the coupling or clutch hub length is greater than the usable shaft length, overhang one or both hubs. For Type T41, if this results in less than one shaft diameter of hub engagement, check key stresses or use a semi-standard long T hub listed in **Table 22, page 39** or submit application details to Rexnord.

CAUTION: The effect of open keyways on coupling or clutch balance should always be considered.

Dimension Y must be equal to or greater than dimension X for clearance fits, or greater than dimension X times 0.75 for interference fits.

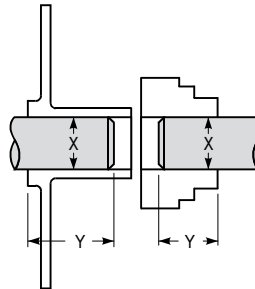

Slip Torque Performance Charts

The following charts are for T41, T41-2, T44 and T44-2 couplings or clutches. The coupling or clutch slip torque setting and operating speed determine the length of time a coupling or clutch can slip without exceeding its thermal capacity. An automatic cutout switch (see **page 20**) is *required* on applications as indicated in the upper right of the charts (Footnote 1) and is recommended on applications where “minutes of slip and non-slip” are exceeded.

CAUTION: Thermal conditions in the slip torque performance charts apply only when the controlled torque hub is mounted on the driving shaft. When the controlled torque hub is mounted on the driven shaft, reduce the slip time by 50%.

During slip, heat is generated at the friction lining surfaces. The following charts specify the thermal capacities. When the torque (slip torque at the slip speed — not motor horsepower) being dissipated during a slip period exceeds the thermal capacity of the coupling or clutch, the following conditions will result:

1. Lining wear that changes the coefficient of friction and slip torque setting.
2. Excessive sleeve bearing wear.
3. Warping of controlled torque hub flange and drive plate flange.
4. Heavy smoke and possibly fire.
5. Complete coupling or clutch failure.

The limits specified in these charts must be adhered to for proper operation of controlled torque couplings or clutches in overload systems. Refer to Factory all applications requiring operation beyond the coupling or clutch thermal capacity.

SIZES 1020T41 & 1020T44

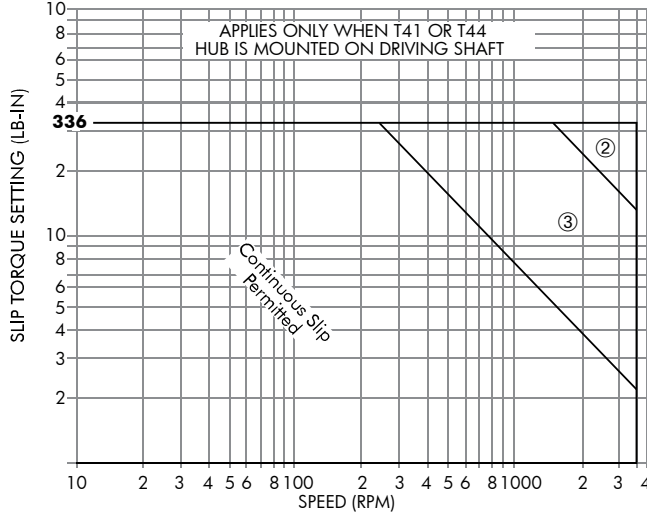

- ② 17 seconds slip permitted if followed by 6 minutes non-slip.
- ③ 34 seconds slip permitted if followed by 6 minutes non-slip.

SIZE 1030T41 & 1030T44

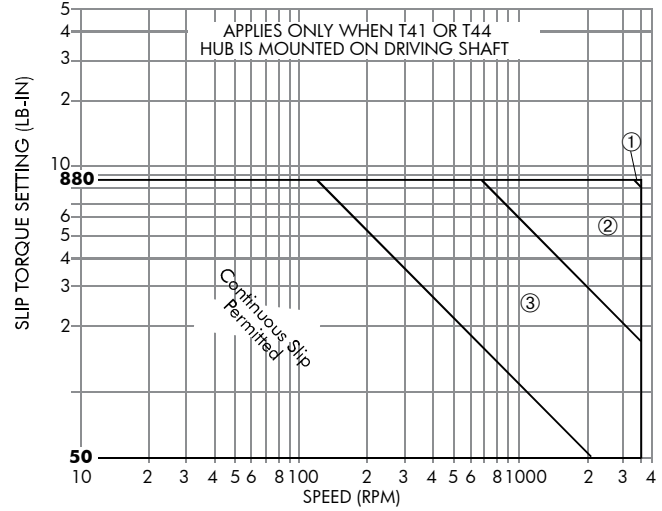

- ① Automatic cutout switch required.
- ② 20 seconds slip permitted if followed by 7 minutes non-slip.
- ③ 40 seconds slip permitted if followed by 7 minutes non-slip.

SIZE 1040T41 & 1040T44

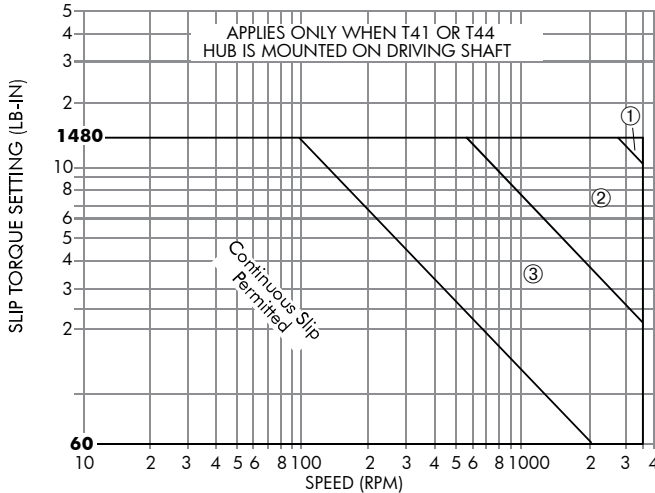

- ① Automatic cutout switch required.
- ② 23 seconds slip permitted if followed by 7-1/2 minutes non-slip.
- ③ 45 seconds slip permitted if followed by 7-1/2 minutes non-slip.

SIZE 1050T41 & 1050T44

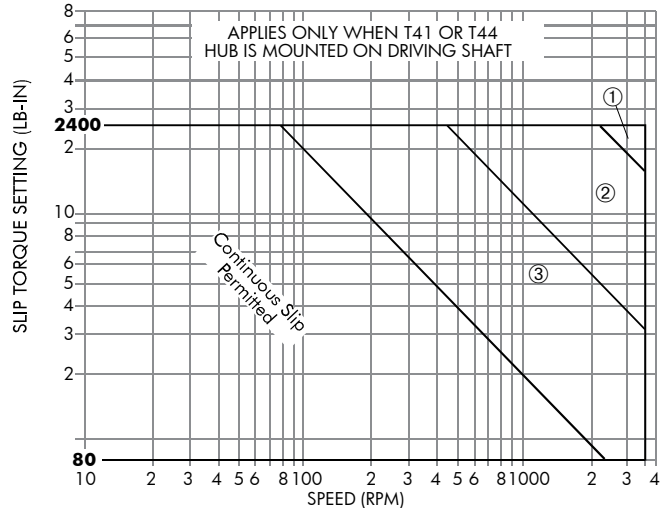

- ① Automatic cutout switch required.
- ② 27 seconds slip permitted if followed by 9 minutes non-slip.
- ③ 54 seconds slip permitted if followed by 9 minutes non-slip.

Slip Torque Performance Charts

SIZE 1060T41 & 1060T44

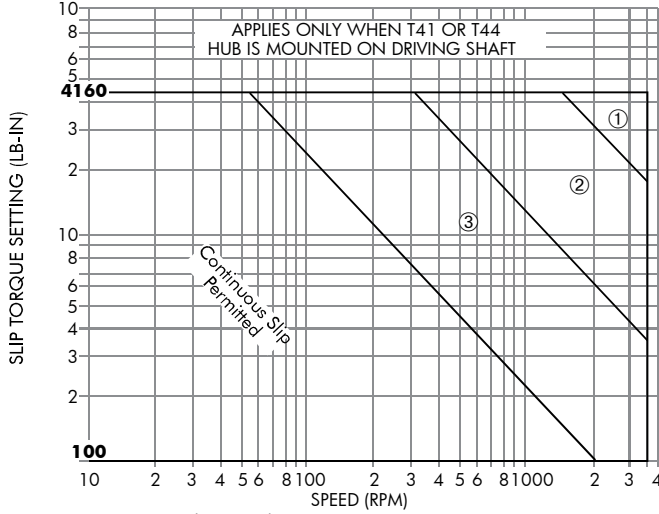

- ① Automatic cutout switch required.
- ② 30 seconds slip permitted if followed by 10 minutes non-slip.
- ③ 60 seconds slip permitted if followed by 10 minutes non-slip.

SIZE 1070T41 & 1070T44

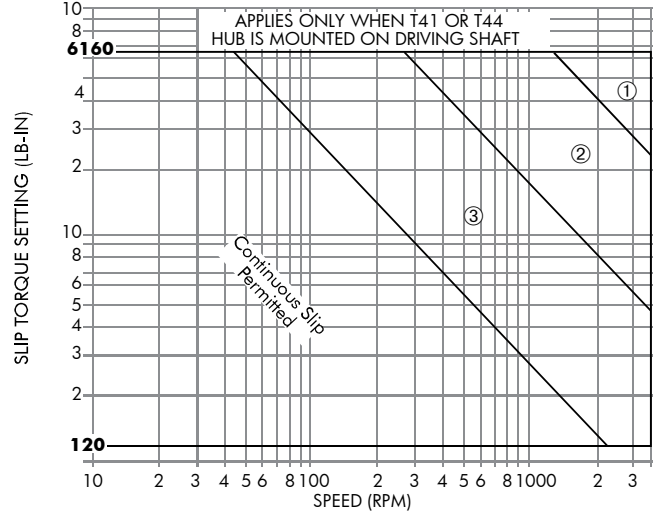

- ① Automatic cutout switch required.
- ② 33 seconds slip permitted if followed by 11 minutes non-slip.
- ③ 66 seconds slip permitted if followed by 11 minutes non-slip.

SIZE 1080T41 & 1080T44

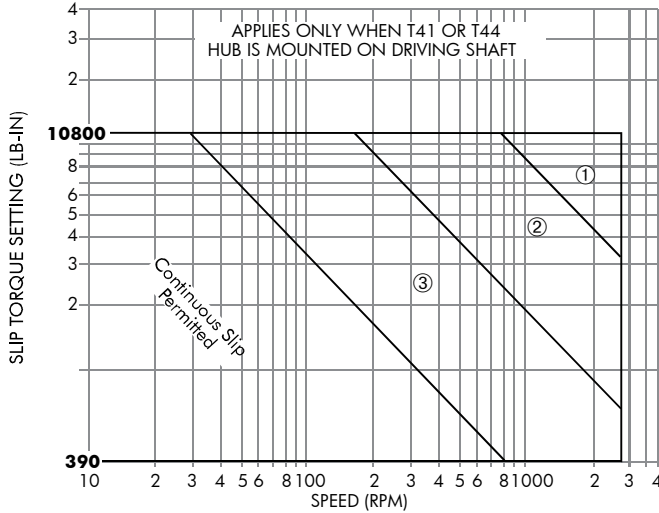

- ① Automatic cutout switch required.
- ② 36 seconds slip permitted if followed by 12 minutes non-slip.
- ③ 72 seconds slip permitted if followed by 12 minutes non-slip.

SIZE 1090T41 & 1090T44

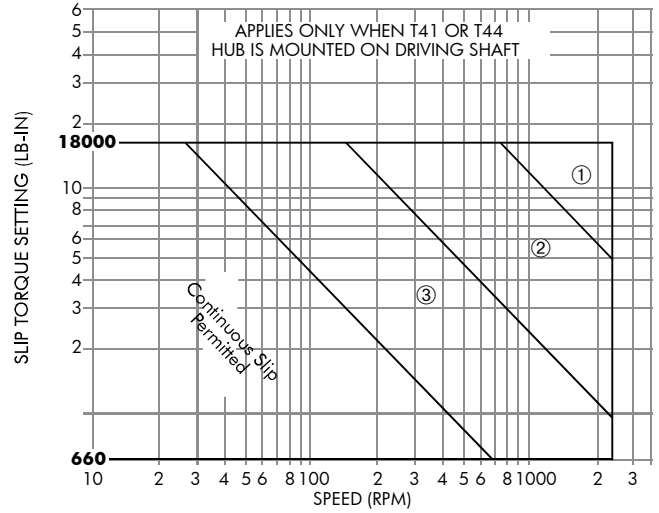

- ① Automatic cutout switch required.
- ② 40 seconds slip permitted if followed by 14 minutes non-slip.
- ③ 80 seconds slip permitted if followed by 14 minutes non-slip.

SIZE 1100T41 & 1100T44

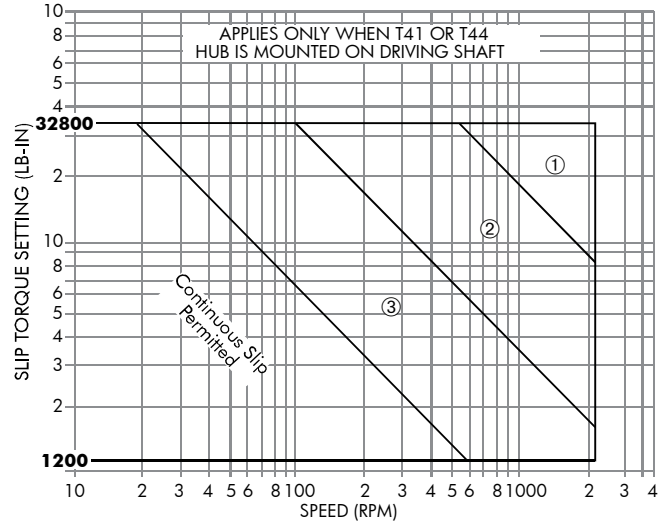

- ① Automatic cutout switch required.
- ② 48 seconds slip permitted if followed by 16 minutes non-slip.
- ③ 96 seconds slip permitted if followed by 16 minutes non-slip.

SIZE 1110T41 & 1110T44

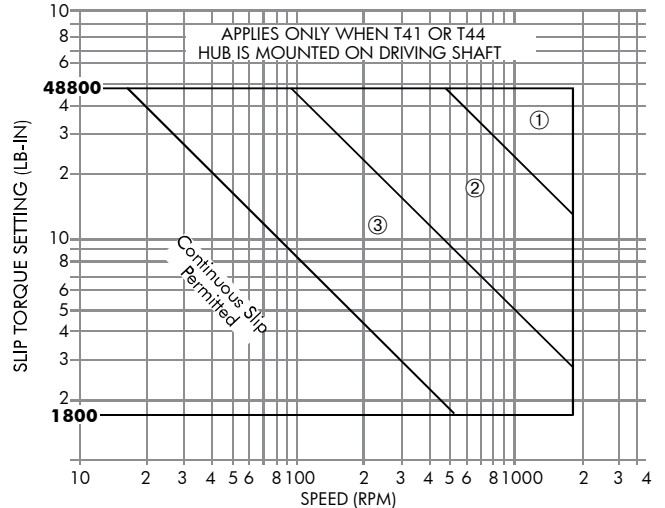

- ① Automatic cutout switch required.
- ② 55 seconds slip permitted if followed by 18 minutes non-slip.
- ③ 110 seconds slip permitted if followed by 18 minutes non-slip.

Slip Torque Performance Charts

SIZE 1120T41 & 1120T44

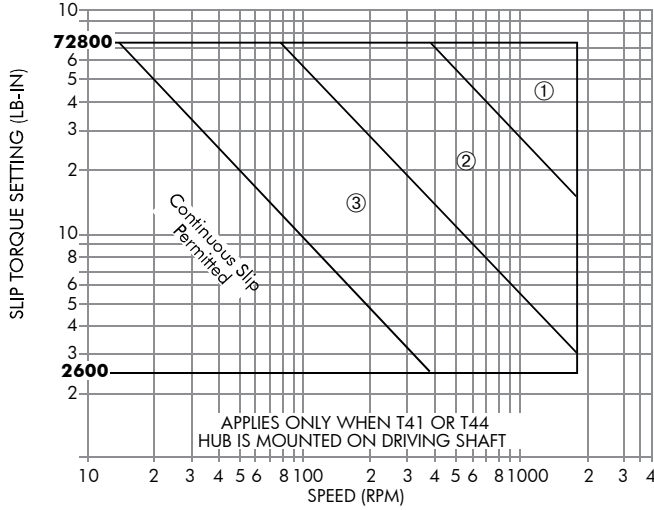

- ① Automatic cutout switch required.
- ② 60 seconds slip permitted if followed by 20 minutes non-slip.
- ③ 120 seconds slip permitted if followed by 20 minutes non-slip.

SIZE 1130T41 & 1130T44

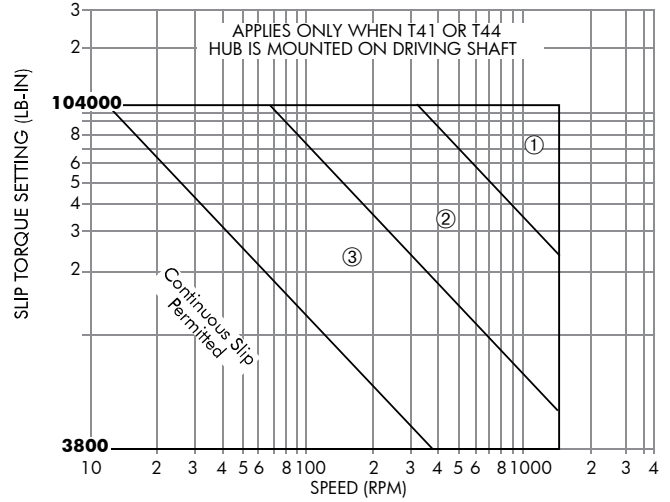

- ① Automatic cutout switch required.
- ② 70 seconds slip permitted if followed by 23 minutes non-slip.
- ③ 140 seconds slip permitted if followed by 23 minutes non-slip.

SIZE 1140T41 & 1140T44

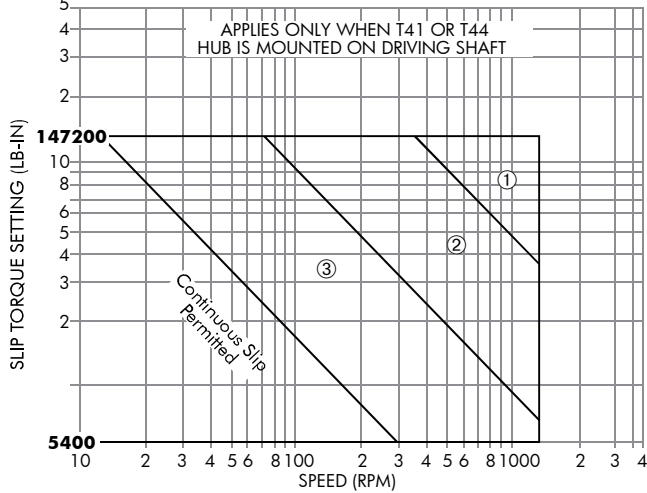

- ① Automatic cutout switch required.
- ② 80 seconds slip permitted if followed by 26 minutes non-slip.
- ③ 160 seconds slip permitted if followed by 26 minutes non-slip.

SIZE 1150T41

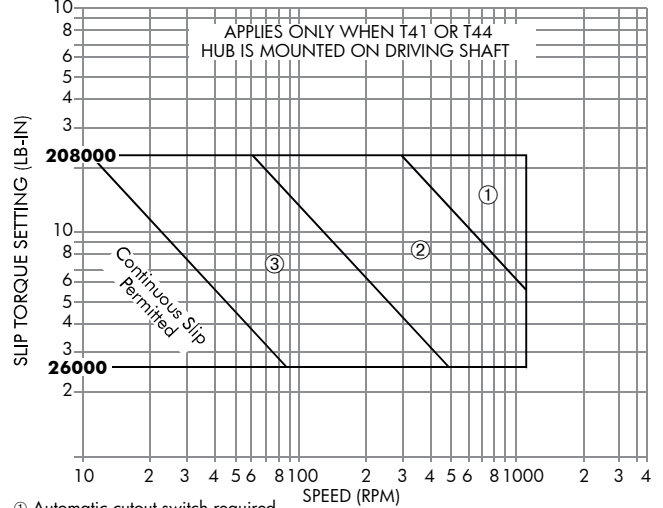

- ① Automatic cutout switch required.
- ② 92 seconds slip permitted if followed by 31 minutes non-slip.
- ③ 184 seconds slip permitted if followed by 31 minutes non-slip.

SIZE 1160T41

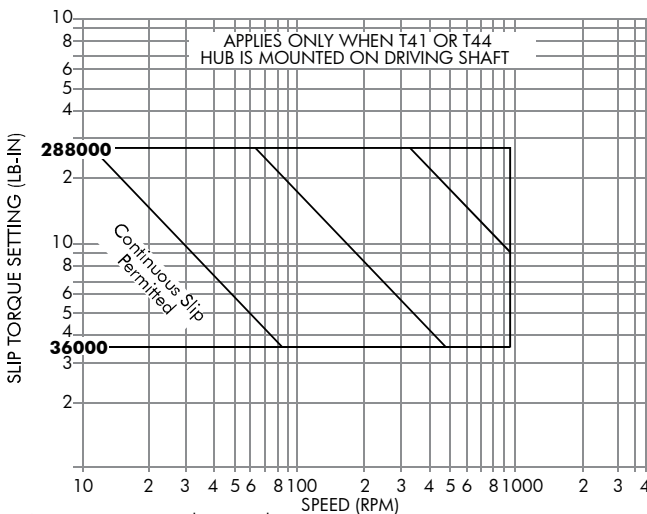

- ① Automatic cutout switch required.
- ② 106 seconds slip permitted if followed by 35 minutes non-slip.
- ③ 212 seconds slip permitted if followed by 35 minutes non-slip.

SIZE 1170T41

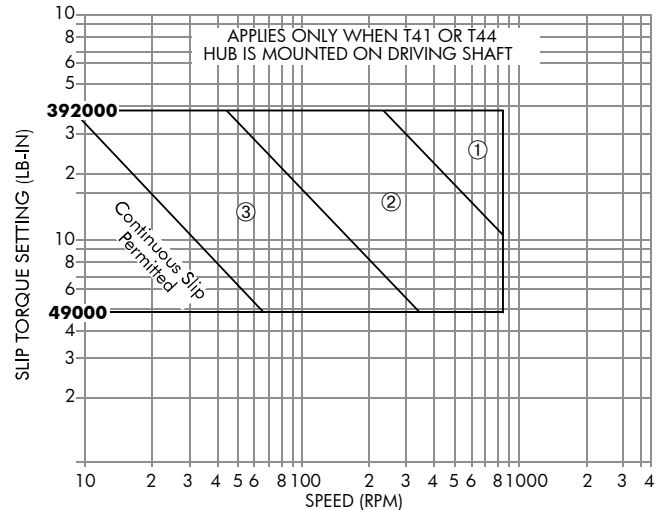

- ① Automatic cutout switch required.
- ② 110 seconds slip permitted if followed by 37 minutes non-slip.
- ③ 220 seconds slip permitted if followed by 37 minutes non-slip.

Slip Torque Performance Charts

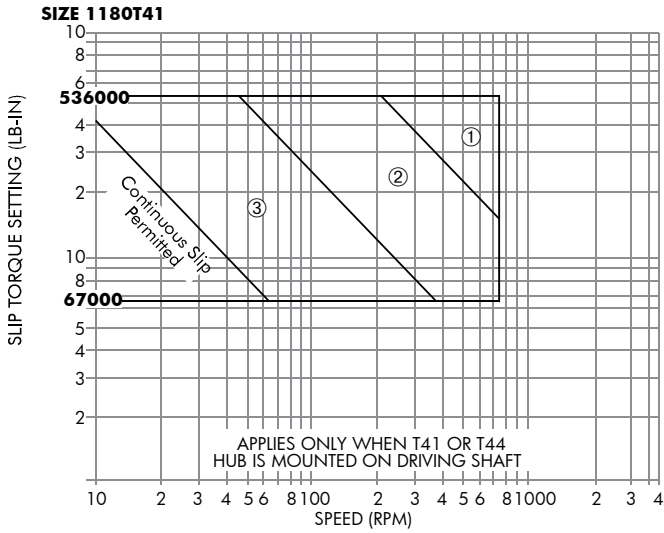

- ① Automatic cutout switch required.
- ② 122 seconds slip permitted if followed by 40 minutes non-slip.
- ③ 244 seconds slip permitted if followed by 40 minutes non-slip.

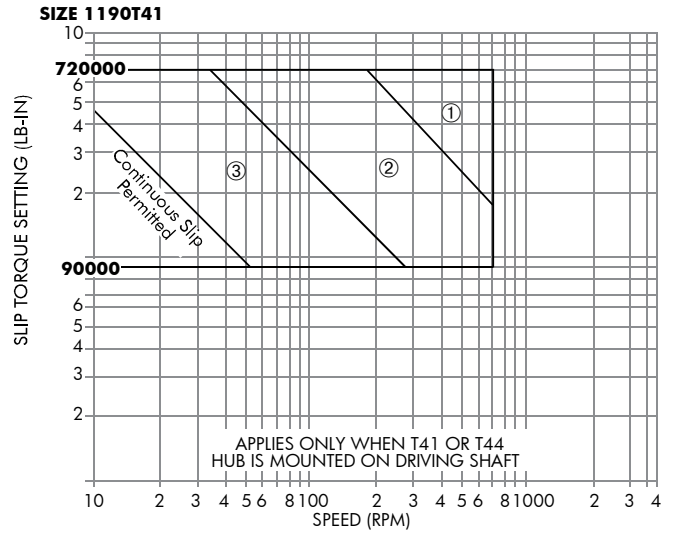

- ① Automatic cutout switch required.
- ② 133 seconds slip permitted if followed by 44 minutes non-slip.
- ③ 266 seconds slip permitted if followed by 44 minutes non-slip.

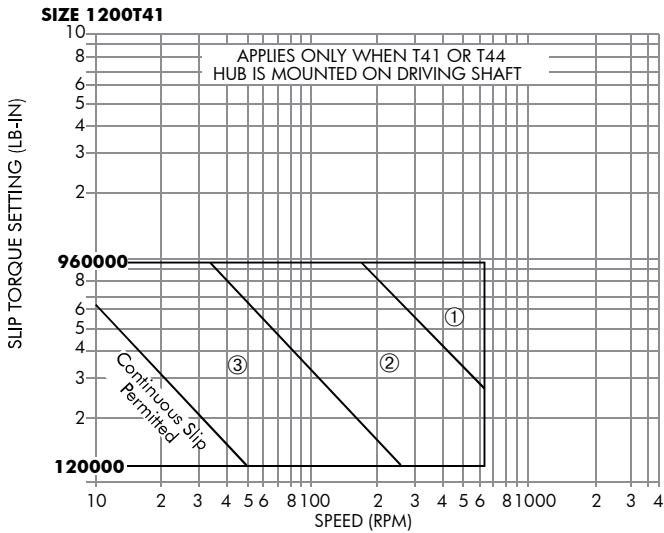

- ① Automatic cutout switch required.
- ② 150 seconds slip permitted if followed by 50 minutes non-slip.
- ③ 300 seconds slip permitted if followed by 50 minutes non-slip.

Floating Shaft Type T50

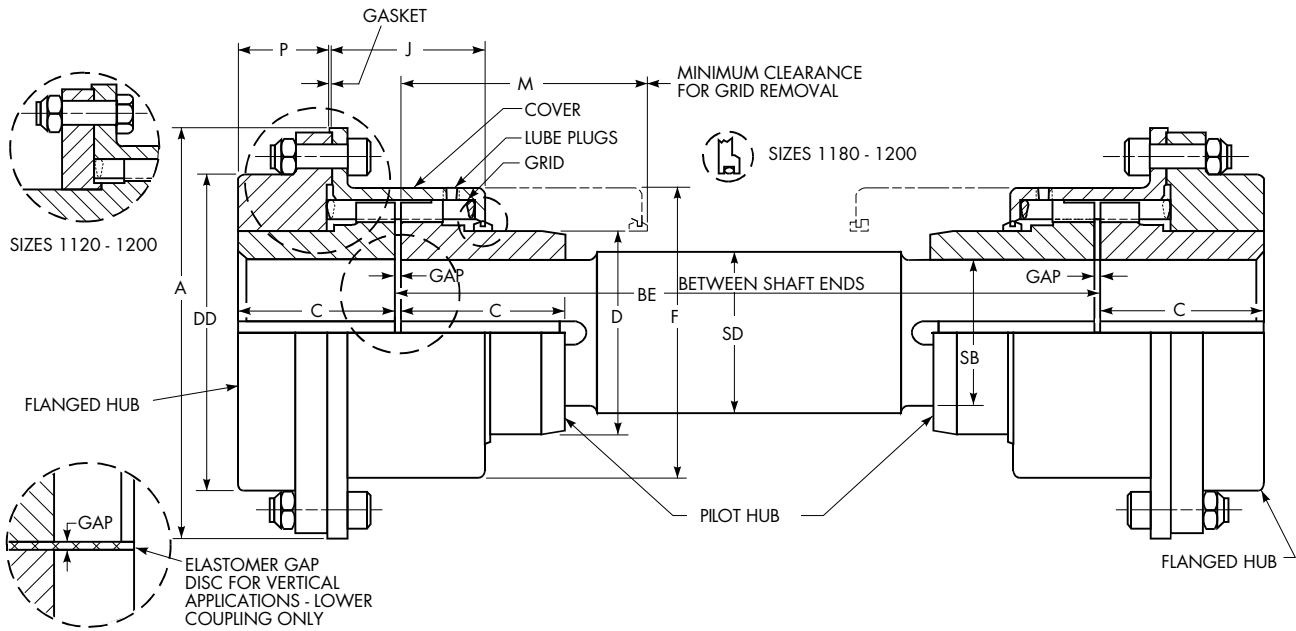

Dimensions (in)

Size ①	Torque Rating (lb-in) ②	Max Bore (Flanged Hub) ③	Min Bore ④	Pilot Hub Bore	Wt Per Cplg No Bore (lb)	Wt Added per Inch of Length of SD Dia Between Hubs	Lube Wt per Cplg (lb)	A	BE Min	C	D	DD	F	J	M	P	SB	SD	GAP
1030T	1,320	1.375	.500	1.06	8.6	0.279	0.09	4.56	6.38	1.88	1.94	3.30	3.18	1.98	3.06	1.06	1.06	1.12	0.125
1050T	3,850	1.875	.500	1.44	19.5	0.500	0.15	6.20	7.66	2.38	2.62	4.14	4.12	2.33	3.70	1.42	1.44	1.50	0.125
1070T	8,800	2.500	.750	1.94	34.4	0.889	0.25	7.20	8.38	3.00	3.44	4.98	5.08	2.56	4.06	1.96	1.94	2.00	0.125
1080T	18,150	3.000	1.062	2.44	58.2	1.390	0.38	8.60	10.82	3.50	4.12	6.10	6.15	3.38	5.28	2.05	2.44	2.50	0.125
1090T	33,000	3.500	1.062	2.94	82	2.000	0.56	9.64	11.56	3.88	4.88	7.10	6.92	3.63	5.66	2.30	2.94	3.00	0.125
1100T	55,550	4.000	1.625	3.62	139	3.130	0.94	11.26	14.65	4.75	5.59	8.32	8.20	4.62	7.14	2.73	3.62	3.75	0.188
1110T	82,500	4.500	1.625	4.00	184	3.770	1.12	12.76	15.38	5.00	6.31	9.66	9.00	4.81	7.50	2.91	4.00	4.12	0.188
1120T	121,000	5.000	2.375	4.62	216	5.010	1.62	12.88	17.82	5.88	7.06	7.06	10.12	5.76	8.66	3.29	4.62	4.75	0.250
1130T	176,000	6.000	2.625	5.25	309	6.430	2.0	14.38	18.22	6.38	8.56	8.56	11.62	5.88	8.86	3.73	5.25	5.38	0.250
1140T	253,000	7.250	2.625	5.62	462	7.350	2.5	16.50	18.98	7.25	10.00	10.00	13.22	6.14	9.24	4.48	5.62	5.75	0.250
1150T	352,000	8.000	4.250	6.38	610	9.390	4.3	18.80	21.62	7.20	10.68	10.60	15.40	6.98	10.56	4.00	6.38	6.50	0.250
1160T	495,000	9.000	4.750	7.88	840	14.200	6.2	21.60	23.10	7.80	12.00	12.00	17.40	7.46	11.30	4.40	7.88	8.00	0.250
1170T	660,000	10.000	5.250	7.88	1144	14.200	7.7	23.80	24.50	8.50	14.00	14.00	19.46	7.92	12.00	4.90	7.88	8.00	0.250
1180T	915,200	11.000	6.000	8.88	1583	18.000	8.3	26.20	26.50	9.40	15.50	15.50	21.90	8.94	13.00	5.56	8.88	9.00	0.250
1190T	1,210,000	12.000	6.000	9.88	1979	22.200	9.7	27.90	28.00	10.20	17.20	17.20	23.60	9.52	13.76	6.20	9.88	10.00	0.250
1200T	1,650,000	13.000	7.000	10.88	2657	26.900	12.4	30.80	29.30	11.00	19.60	19.60	26.10	9.92	14.40	6.80	10.88	11.00	0.250

- ① Refer to **page 10** for General Information.
- ② Peak torque capacity is two times the published rating.
- ③ Maximum bores are reduced for hubs furnished with an interference fit and a setscrew over the keyway. Refer to Rexnord Engineering Sheet 427-105 for details.
- ④ Minimum bore is the smallest bore to which a Rough Stock Bore (RSB) hub can be bored. Depending upon coupling size, RSB hubs may have only a blind centering hole or a through hole that will permit remachining of the hubs to the minimum bores specified.

Floating Shaft Type T50

Floating Shaft/Selections

Introduction — Floating shaft diameters have been preselected to transmit the coupling torque and need only to be checked for allowable speed.

Construction — Standard shafts are solid, AISI 1018 or 1020 cold rolled steel. Also available is an optional solid, AISI 1018, fully turned, hot-rolled steel shaft.

Determine the Allowable Shaft Length

- Select the coupling size per **page 6** and **25**.
- From **page 25**, determine shaft diameter (Dimension SD) for the coupling selected.
- From the **Table 12**, locate the floating shaft diameter (Dimension SD) determined in Step B.

D. Determine the allowable shaft length for the required operating speed.

For speeds under 540 rpm — Read the maximum allowable shaft length to the left of the required shaft diameter.

For speeds over 540 rpm — Trace right from the shaft diameter determined along the diagonal line to the point of intersection with the required vertical operating speed line. Trace right along the horizontal line to the right and read the maximum allowable shaft length.

- Determine if shaft requires balancing. Locate point where operating speed and floating shaft length cross. Balance is required when point is located to the right of bold line.
- If a longer shaft is required, reduce the operating speed if practical, or select the next larger size coupling.

NOTE: For such conditions, the use of a tubular shaft design should be considered. Refer application details to the local Rexnord representative.

Table 12 — Floating Shaft Selections

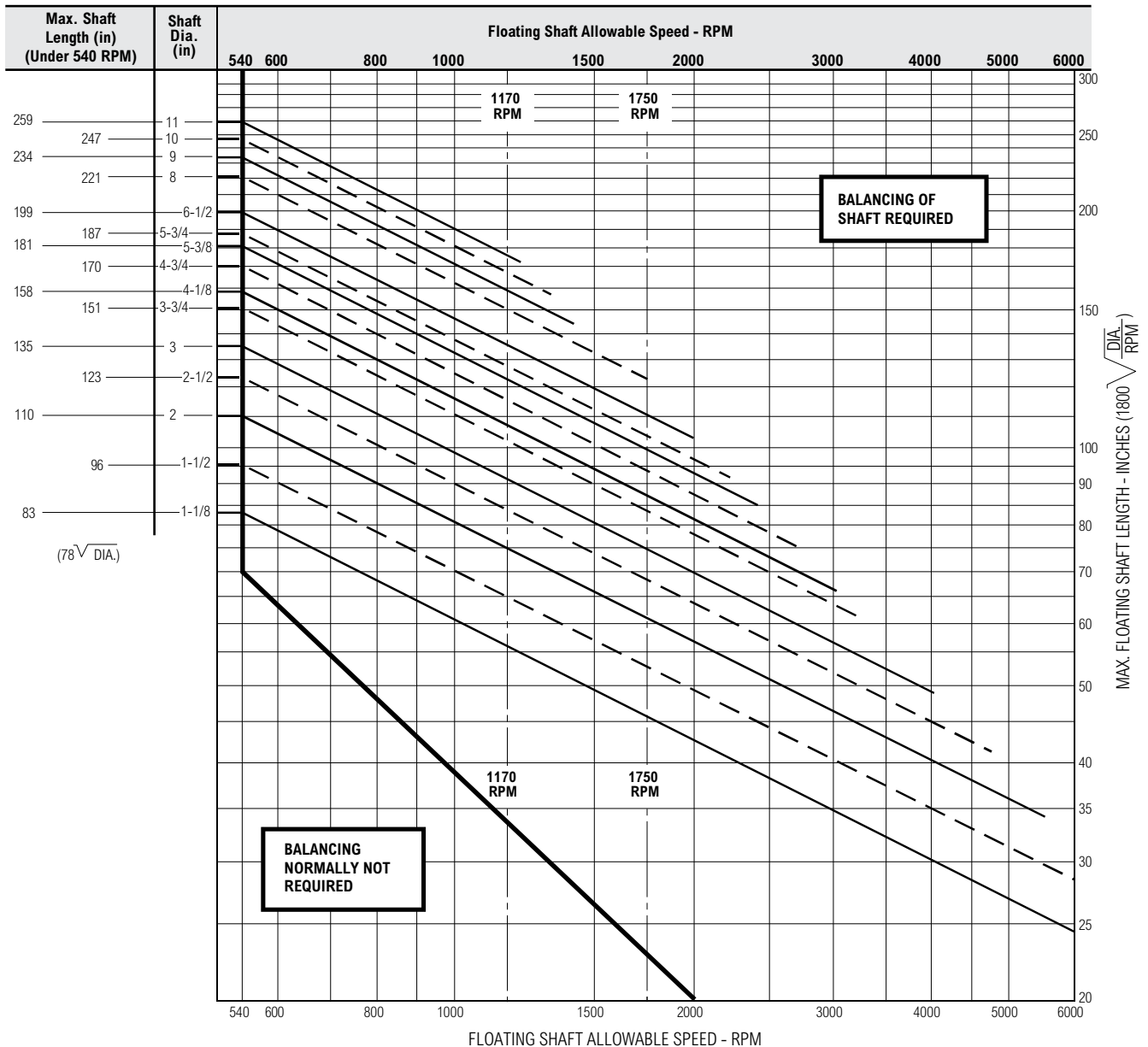

Caliper Disc Brake System

Rexnord will supply Type T63 Brake Disc Couplings for use with calipers and power systems by others, or a fail-safe Falk Caliper Disc Brake System. The system is comprised of a Falk Steelflex Coupling, caliper disc brake, basic hydraulic circuits and components. These systems are designed to be used as parking or holding brakes or limited usage dynamic stopping brakes.

Rexnord will purchase for resale the caliper disc brakes and hydraulic components preassembled in a power package.

Rexnord can assemble or mount the T63 coupling, disc brake and hydraulic system when these components are ordered in conjunction with Falk gear drives.

Capabilities

The Falk Steelflex Disc Brake Coupling with Caliper Brake System has an assigned coupling brake rating range of 8 to 12,500 ft-lbs.

Description of the Disc Brake Coupling and Caliper System

The system consists of a standard T63 coupling using a disc diameter and thickness compatible with one caliper brake manufacturer. Both MICO-Minnesota Automotive Inc. and Goodyear Aerospace Corporation caliper disc brakes are used on Sizes 50T63 through 120T63 and 130T63, respectively. Both caliper manufacturers use different mounting hole patterns and bracket styles. MICO and Goodyear caliper disc brakes require hydraulic pressure.

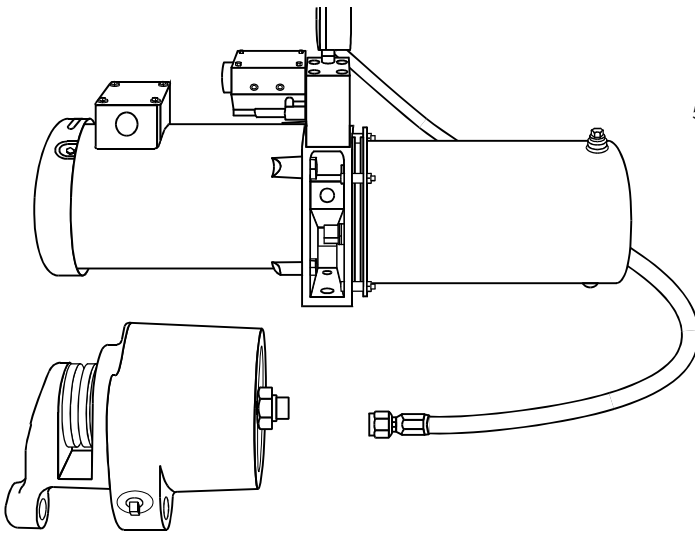

Caliper Disc Brakes

The caliper disc brake is spring-loaded to apply the brake. Hydraulic pressure is required to release or "hold off" the brake. Normal operation is to have the brake pressurized in the released position with the hydraulic system running. Conditions such as an electric power or pressure system failure, which reduces the system pressure below the release pressure of the brake, will initiate a brake application.

Hydraulic Brake System

The system consists of an oil tank, filter, gear pump and electric motor, relief valve, check valve, solenoid direction control valve, pressure gauge, duplex pressure switch, 5-foot hydraulic hose with connections and caliper disc brake.

Operation

The hydraulic brake system is actuated by turning on its electric motor. The motor drives a gear pump which produces a flow of oil between pump and solenoid directional control valve. When the solenoid directional control valve is energized, oil pressure rises in the caliper brake, compressing the Belleville springs to release the brake.

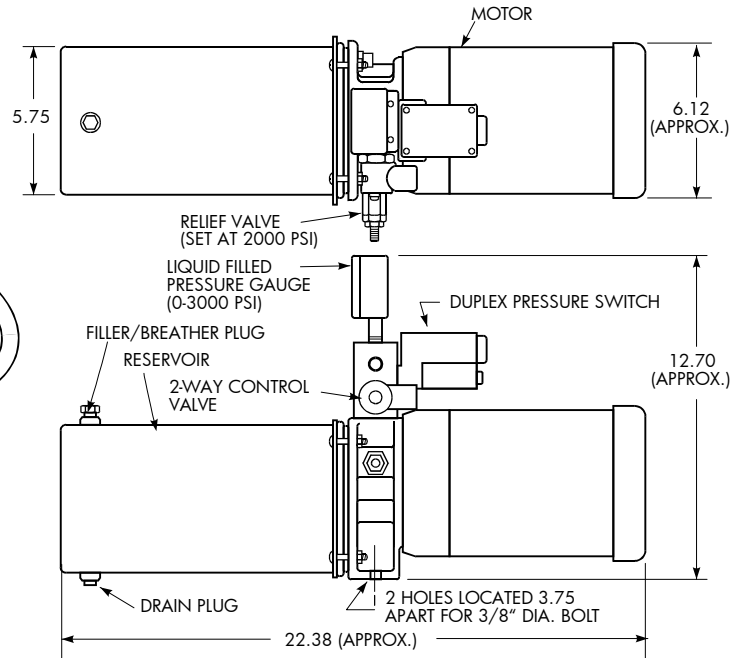

Disc Brake Type T63

NOTE: Falk Type T63 couplings or brake assemblies are not approved as a primary brake for applications used to lift or transport people such as elevators, escalators, hoists, lifts, etc.

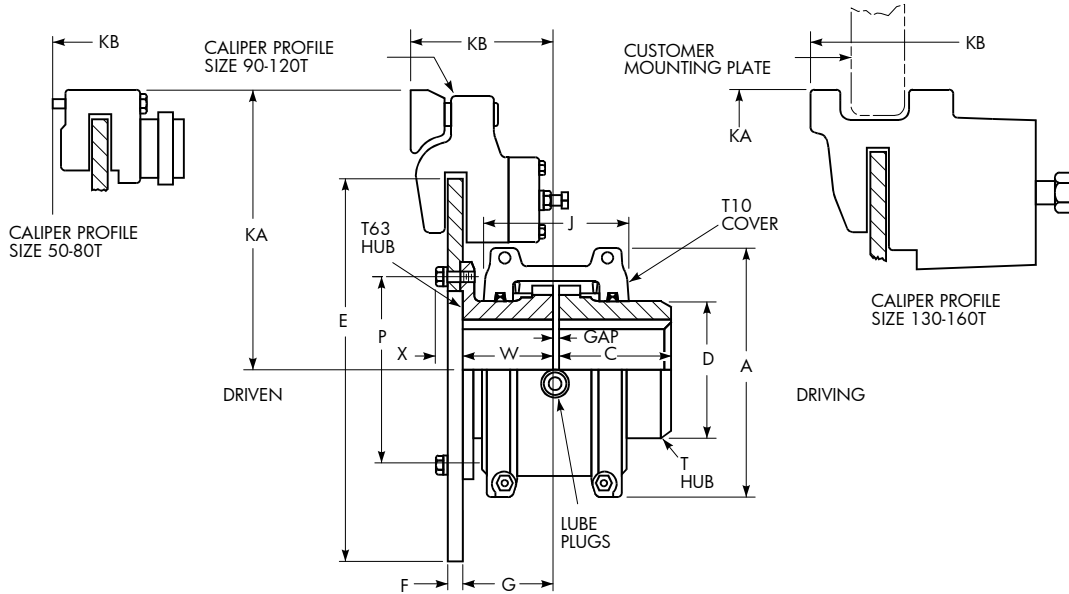

Dimensions (in)

Size ①	Cplg Brake Rating (lb-ft)	Brake Disc Dia x Thickness (E x F) ③	Allow Speed RPM ④	Max Bore ②	Min Bore ⑤	Cplg Wt with No Bore & No Disc (lb)	Lube Wt (lb)	A	C	D	G	J	P	W	X	GAP
20T	8	8 x 0.25	4500	1.125	0.500	5.63	0.06	3.82	1.88	1.56	2.36	2.62	2.812	2.38	0.46	0.125
30T	26	10 x 0.25	4500	1.375	0.500	7.29	0.09	4.16	1.88	1.94	2.36	2.69	3.125	2.38	0.46	0.125
40T	48	10 x 0.25	4500	1.625	0.500	9.40	0.12	4.50	2.00	2.25	2.36	2.75	3.875	2.38	0.46	0.125
50T	87	10 x 0.25	4150	1.875	0.500	14.00	0.15	5.32	2.38	2.62	2.36	3.12	4.250	2.38	0.52	0.125
60T	154	12 x 0.25	3800	2.125	0.750	21.10	0.19	5.82	2.50	3.00	3.49	3.62	4.938	3.47	0.60	0.125
70T	244	12 x 0.25	3250	2.500	0.750	27.20	0.25	6.25	3.00	3.44	3.49	3.75	5.250	3.47	0.60	0.125
80T	470	12 x 0.25	2850	3.000	1.062	43.60	0.38	7.50	3.50	4.12	3.49	4.56	6.000	3.47	0.71	0.125
90T	800	16 x 0.50	2700	3.500	1.062	62.60	0.56	8.31	3.88	4.88	3.46	4.81	7.062	3.47	1.06	0.125
100T	1400	16 x 0.50	2400	4.000	1.625	105	0.94	9.88	4.75	5.59	4.69	6.12	8.500	4.69	1.16	0.188
110T	2100	18 x 0.50	2250	4.500	1.625	143	1.12	10.62	5.00	6.31	5.75	6.36	9.500	5.75	1.16	0.188
120T	3200	20 x 0.50	2025	5.000	2.375	203	1.62	12.12	5.88	7.06	5.91	7.54	10.875	5.88	1.30	0.250
130T	4500	22 x 0.50	1800	6.000	2.625	290	2.00	13.62	6.38	8.56	6.04	7.68	11.625	6.00	1.40	0.250
140T	6500	24 x 0.50	1650	7.250	2.625	407	2.50	15.12	7.25	10.00	6.29	7.92	13.000	6.25	1.50	0.250
150T	9000	30 x 0.50	1500	8.000	4.250	558	4.20	17.84	7.20	10.60	7.08	10.68	14.500	7.20	1.24	0.250
160T	12500	36 x 0.50	1350	9.000	4.750	741	6.20	19.76	7.80	12.00	7.68	10.98	15.750	7.80	1.24	0.250

① Refer to **page 10** for General Information.

② Couplings will be furnished for interference fit without a setscrew. Clearance fit and/or hubs with setscrews are not recommended. Rexnord standards apply unless otherwise specified. Maximum bores listed are based on recommended keys shown in **Table 26, page 40**. For other maximum bore-key combinations that can be manufactured to order, refer to **Table 14, page 34**.

③ Refer to Rexnord for discs with dimensions other than shown.

④ Consult Factory for higher speeds.

⑤ Minimum bore is the smallest bore to which a Rough Stock Bore (RSB) hub can be bored. Depending upon coupling size, RSB hubs may have only a blind centering hole or a through hole that will permit remachining of the hubs to the minimum bores specified.

Disc Brake Type T63

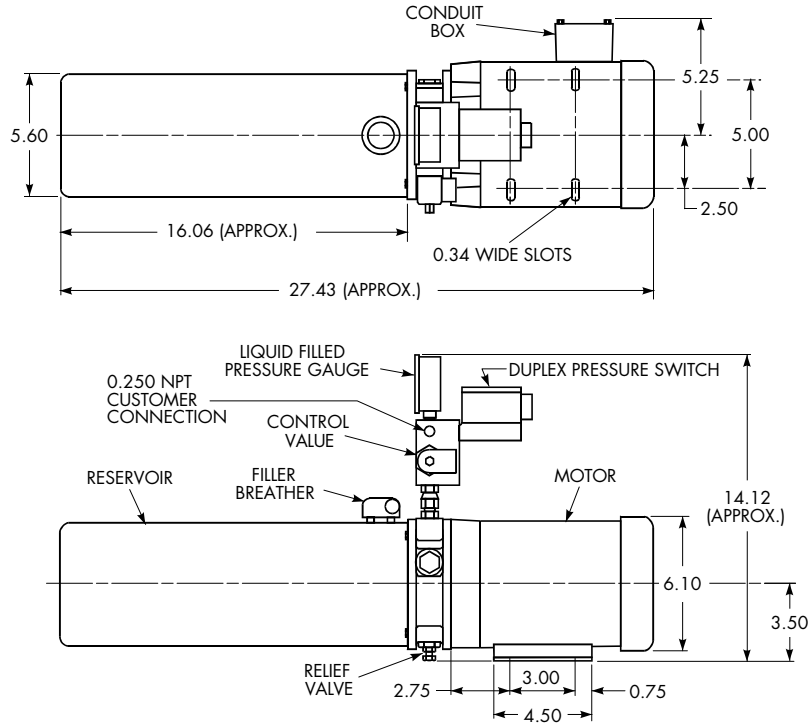

Caliper System Dimensions (in)

Coupling Size	Caliper Brake ②				KA	KB ③
	Brand	Model No. ①	Torque (lb-ft)			
			Min	Max		
20T	These sizes are best activated by Electromagnetic or Pneumatic Caliper Systems					
30T						
40T						
50T	MICO, Inc.	02-515-002	46	90	6.22	3.80
60T		02-515-004	116	180	7.22	4.93
70T		02-515-008	350	410	7.22	4.93
80T		02-515-006	466	570	7.22	4.93
90T		02-530-306	517	1,074	11.50	5.46
100T		02-530-628	534	1,830	11.50	6.69
110T		02-530-628	612	2,100	12.50	7.75
120T	02-530-600	1,389	3,290	13.50	7.91	
130T	Meritor	PD1591 15 1	1,625	6,094	13.25	8.54
140T		PD1591 15 1	1,792	6,719	14.25	8.79
150T		SCL25 15 4	3,438	17,188	18.18	9.68
160T		SCL25 15 4	4,188	20,938	21.22	10.28

- ① These brakes use hydraulic oil (NOT brake fluid). Any high grade hydraulic oil with viscosities of 150 SSU-350 SSU @ 100°F is suitable.
- ② Maximum torque shown is rating with new pads. Minimum torque shown is rating at point when caliper requires adjustment for pad wear.
- ③ Dimension KB is to caliper mounting surface for Coupling Sizes 50T thru 120T, and to caliper edge for Coupling Sizes 130T and larger.

High-Speed Type T70

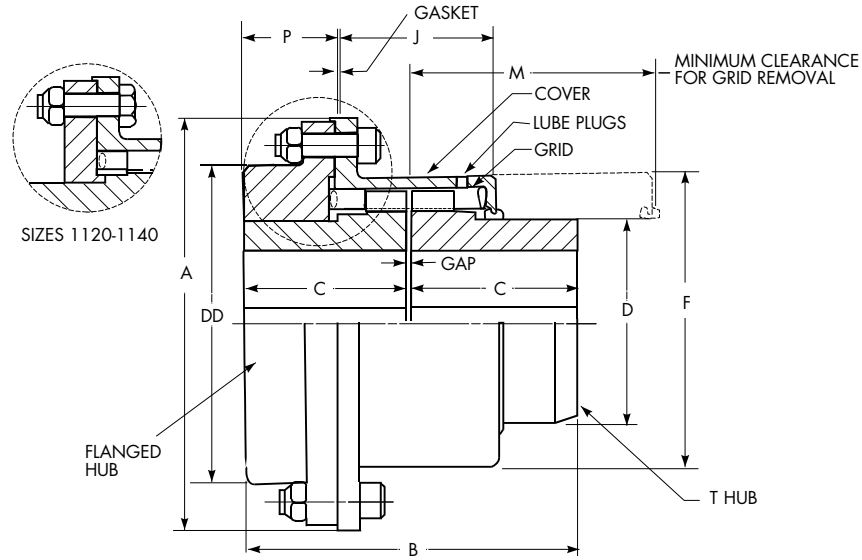

Dimensions (in)

Size ①	Torque Rating (lb-in) ③	Allow Speed RPM ④	Max Bore ⑤	Min Bore ⑥	Cplg Wt with No Bore (lb)	Lube Wt (lb)	A	B	C	D	DD	F	J	M	P	GAP
1030T	1,320	10,000	1.375	0.500	8.6	0.09	4.56	3.88	1.88	1.94	3.30	3.18	1.98	3.06	1.06	0.125
1050T	3,850	9,000	1.875	0.500	19.5	0.15	6.20	4.88	2.38	2.62	4.14	4.12	2.33	3.70	1.42	0.125
1070T	8,800	8,200	2.500	0.750	34.4	0.25	7.20	6.12	3.00	3.44	4.98	5.08	2.56	4.06	1.96	0.125
1080T	18,150	7,100	3.000	1.062	58.2	0.38	8.60	7.12	3.50	4.12	6.10	6.15	3.38	5.28	2.05	0.125
1090T	33,000	6,000	3.500	1.062	82	0.56	9.64	7.88	3.88	4.88	7.10	6.92	3.63	5.66	2.30	0.125
1100T	55,550	4,900	4.000	1.625	139	0.94	11.26	9.69	4.75	4.59	8.32	8.20	4.62	7.14	2.73	0.188
1110T	82,500	4,500	4.500	1.625	184	1.12	12.76	10.19	5.00	6.31	9.66	9.00	4.81	7.50	2.91	0.188
1120T	121,000	4,000	5.000	2.375	216	1.62	12.88	12.00	5.88	7.06	7.06	10.12	5.76	8.66	3.29	0.250
1130T	176,000	3,600	6.000	2.625	309	2.0	14.38	13.00	6.38	8.56	8.56	11.62	5.88	8.86	3.73	0.250
1140T	253,000	3,300	7.250 ②	2.625	462	2.5	16.50	14.75	7.25	10.00	10.00	13.22	6.14	9.24	4.48	0.250

① Refer to **page 10** for General Information.

② Maximum bore is for hub with keyway for rectangular key.

③ Peak torque capacity is two times the published rating. Torque ratings for hubs with bushings differ from those shown, refer to **Table 18, page 36**.

④ Consult Factory for higher speeds.

⑤ Maximum bores are reduced for hubs furnished with an interference fit and a setscrew over the keyway. Refer to Rexnord Engineering Sheet 427-105 for details.

⑥ Minimum bore is the smallest bore to which a Rough Stock Bore (RSB) hub can be bored. Depending upon coupling size, RSB hubs may have only a blind centering hole or a through hole that will permit remachining of the hubs to the minimum bores specified.

Engine Flywheel Adapter Type T90

Used primarily to connect the flywheel of an engine to the driven machinery. Adapter plates are designed to accommodate standard SAE J620 bolt patterns. The T90 design provides for higher torque ratings with resulting smaller sizes and lower costs than elastomeric coupling designs. The flexible gridmember provides torsional damping in addition to accepting misalignment. Adapter plates are bolted and doweled to the hub to provide a secure joint.

Selection — Determine the proper Steelflex coupling size using the selection method. Check size selected against those shown in table below for the clutch size used on the engine flywheel. If the coupling size is not shown, refer all details to Rexnord.

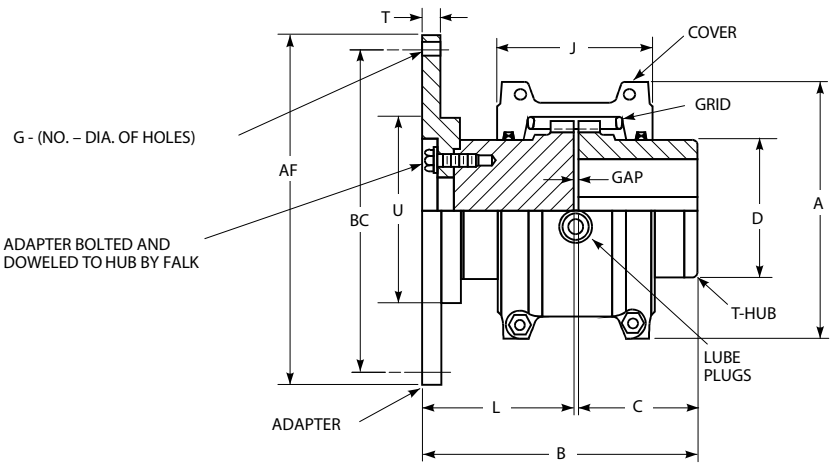

Dimensions (in)

Clutch Diameter	Adapter				Cplg Size ①	Asmly Torque Rating (lb-in) ④	Allow Speed RPM ⑤	Max Bore Sq Key ⑥	Min Bore ⑦	Cplg Wt No Bore In T-Hub (lb)	WR ² (lb-in ²)	A	B	C	D	J	L	GAP
	AF +.000 - .005	BC	G	T														
6.5	8.500	7.875	6 - 0.344	0.375	1050T	3500	3600	1.875	0.500	18	85	5.32	5.58	2.38	2.62	3.12	3.07	0.125
				0.375	1060T	5500	3600	2.125	0.750	23	106	5.82	5.94	2.50	3.00	3.62	3.31	0.125
				0.375	1070T	8000	3600	2.500	0.750	29	130	6.25	6.94	3.00	3.44	3.75	3.81	0.125
7.5	9.500	8.750	8 - 0.344	0.375	1050T	3500	3600	1.875	0.500	20	115	5.32	5.58	2.38	2.62	3.12	3.07	0.125
				0.375	1060T	5500	3600	2.125	0.750	24	136	5.82	5.94	2.50	3.00	3.62	3.31	0.125
				0.375	1070T	8000	3600	2.500	0.750	30	160	6.25	6.94	3.00	3.44	3.75	3.81	0.125
8	10.375	9.625	6 - 0.406	0.375	1050T	3500	3600	1.875	0.500	21	151	5.32	5.58	2.38	2.62	3.12	3.07	0.125
				0.375	1060T	5500	3600	2.125	0.750	26	172	5.82	5.94	2.50	3.00	3.62	3.31	0.125
				0.375	1070T	8000	3600	2.500	0.750	32	196	6.25	6.94	3.00	3.44	3.75	3.81	0.125
				0.500	1080T	16,500	3600	3.000	1.062	48	332	7.50	8.07	3.50	4.12	4.56	4.44	0.125
10	12.375	11.625	8 - 0.406	0.500	1080T	16,500	3600	3.000	1.062	53	494	7.50	8.07	3.50	4.12	4.56	4.44	0.125
11.5	13.875	13.125	8 - 0.406	0.500	1090T	30,000	3600	3.500	1.062	74	820	8.31	8.95	3.88	4.88	4.81	4.94	0.125
14	18.375	17.250	8 - 0.531	0.650	1100T	50,500	2440	4.000	1.625	133	2702	9.88	10.90	4.75	5.59	6.12	5.96	0.188
				0.750	1110T	75,000	2250	4.500	1.625	162	3297	10.62	11.50	5.00	6.31	6.36	6.31	0.188
16	20.375	19.250	8 - 0.531	0.650	1100T	50,500	2440	4.000	1.625	145	3750	9.88	10.90	4.75	5.59	6.12	5.96	0.188
				0.750	1110T	75,000	2250	4.500	1.625	175	4507	10.62	11.50	5.00	6.31	6.36	6.31	0.188
18	22.500	21.375	6 - 0.656	0.750	1110T	75,000	2250	4.500	1.625	190	6243	10.62	11.50	5.00	6.31	6.36	6.31	0.188
				0.750	1120T	110,000	2025	5.000	2.375	243	7165	12.12	13.43	5.88	7.06	7.54	7.30	0.250
				0.900	1130T	160,000	1800	6.000	2.625	331	9737	13.62	14.69	6.38	8.56	7.68	8.06	0.250
21	26.500	25.250	12 - 0.656	0.900	1130T	160,000	1800	6.000	2.625	371	15560	13.62	14.69	6.38	8.56	7.68	8.06	0.250
				1.000	1140T	230,000	1650	7.250 ②	2.625	478	19609	15.12	16.53	7.25	10.00	7.92	9.03	0.250
				1.000	1150T	320,000	1500	8.000 ②	4.250	608	25878	17.84	16.56	7.20	10.60	10.69	9.11	0.250
24	28.875	27.250	12 - 0.812	0.900	1130T	160,000	1800	6.000	2.625	397	20463	13.62	14.69	6.38	8.56	7.68	8.06	0.250
				1.000	1140T	230,000	1650	7.250 ②	2.625	507	25058	15.12	16.53	7.25	10.00	7.92	9.03	0.250
				1.000	1150T	320,000	1500	8.000 ②	4.250	638	31353	17.84	16.56	7.20	10.60	10.69	9.11	0.250
Machined as Required				1.000	1160T	450,000	1350	9.000 ②	4.750	656 ③	-	19.76	17.85	7.80	12.00	10.96	9.80	0.250
				1.250	1170T	600,000	1225	10.000 ②	5.250	902 ③	-	22.32	19.50	8.50	14.00	12.10	10.75	0.250

- ① See page 10 for General Information and Reference Notes.
- ② Maximum bore is for hub with keyway for rectangular key.
- ③ For total coupling weight add $[0.2223 \times (AF^2 - U^2) \times T]$ to value shown. Size 1160 U = 15.50, Size 1170 U = 17.25.
- ④ Peak torque capacity is two times the published rating. Torque ratings for hubs with bushings differ from those shown, refer to Table 18, page 36.
- ⑤ Consult Factory for higher speeds.
- ⑥ Maximum bores are reduced for hubs furnished with an interference fit and a setscrew over the keyway. Refer to Rexnord Engineering Sheet 427-105 for details.
- ⑦ Minimum bore is the smallest bore to which a Rough Stock Bore (RSB) hub can be bored. Depending upon coupling size, RSB hubs may have only a blind centering hole or a through hole that will permit remachining of the hubs to the minimum bores specified.

Floating Shaft Type T10/G82

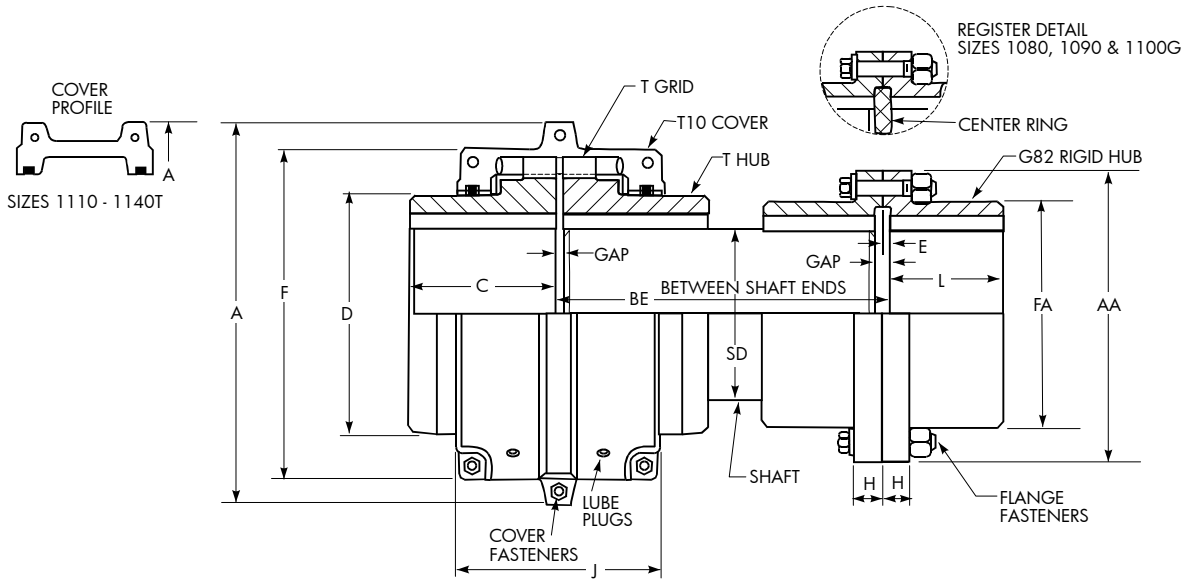

Dimensions (in)

T10 Cplg Size ①	G82 Cplg Size ①	Torque Rating (lb-in) ③	Allow Speed RPM ④	Max Bore ⑤		Min Bore ⑥		Cplg Wt with No Bore & No Shaft (lb)	Wt Added per Inch of SD Dia Between Hubs (lb)	Lube Wt (lb)	A	BE		C	D	E	F	H	J	L	AA	FA ②	SD	GAP		Flange Fasteners	
				T10 Hub	G82 Hub	T10 Hub	G82 Hub					Min	Max											T Hub	G82 Hub	No. per Flange & Grade	Dia (in)
1110T	1035G	82,500	2250	4.500	5.875	1.625	2.000	275	4.50	1.12	10.62	9.41	12	5.00	6.31	0.10	—	1.12	6.36	4.02	11.00	8.32	4.500	0.188	0.200	8,Gr 8	0.750
1120T	1040G	121,000	2025	5.000	7.250	2.375	2.500	404	5.56	1.62	12.12	10.99	14	5.88	7.06	0.16	—	1.12	7.54	4.54	12.50	9.66	5.000	0.250	0.320	8,Gr 8	0.750
1130T	1045G	176,000	1800	6.000	8.125	2.625	3.000	576	8.00	2.00	13.62	12.09	15	6.38	8.56	0.16	—	1.12	7.68	5.14	13.62	10.79	6.000	0.250	0.320	10,Gr 8	0.750
1140T	1050G	253,000	1650	7.250	9.000	2.625	3.500	842	11.7	2.50	15.12	13.70	16	7.25	10.00	0.20	—	1.50	7.92	5.80	15.31	12.04	7.250	0.250	0.400	8,Gr 8	0.875
1150T	1055G	352,000	1500	8.000	10.000	4.250	4.000	1120	14.2	4.30	17.84	14.65	16	7.20	10.60	0.20	15.37	1.50	10.68	6.80	16.75	13.16	8.000	0.250	0.400	14,Gr 8	0.875
1160T	1060G	495,000	1350	9.000	11.000	4.750	4.500	1421	18.0	6.20	19.74	15.91	18	7.80	12.00	0.26	17.18	1.00	10.98	7.34	18.00	14.41	9.000	0.250	0.520	14,Gr 8	0.875
1170T	1070G	660,000	1225	10.000	13.000	5.250	5.000	2167	22.2	7.70	22.30	18.08	20	8.50	14.00	0.33	19.18	1.12	11.98	8.67	20.75	16.73	10.000	0.250	0.660	16,Gr 8	1.000
1180T	1080G	915,200	1100	11.000	13.000	6.000	4.000	2894	26.9	8.30	24.80	20.09	26	9.40	15.50	0.32	21.84	1.24	12.64	9.80	23.25	17.75	11.000	0.250	0.640	16,Gr 5	1.125
1190T	1090G	1,210,000	1050	12.000	14.250	6.000	4.500	3871	32.0	9.70	26.60	21.95	28	10.20	17.20	0.32	23.93	1.50	12.80	10.86	26.00	20.00	12.000	0.250	0.640	18,Gr 5	1.250
1200T	1100G	1,650,000	900	13.000	15.000	7.000	5.000	4970	37.6	12.40	29.80	23.99	30	11.00	19.60	0.36	26.00	1.75	14.00	12.02	28.00	20.88	13.000	0.250	0.720	18,Gr 5	1.250

- ① Refer to **page 10** for General Information.
- ② Dimension FA is for an as-cast, unmachined surface for Sizes 1180, 1190 & 1200.
- ③ Peak torque capacity is two times the published rating. Torque ratings for hubs with bushings differ from those shown, refer to **Table 18, page 36**.
- ④ Consult Factory for higher speeds.
- ⑤ Maximum bores are reduced for hubs furnished with an interference fit and a setscrew over the keyway. Refer to Rexnord Engineering Sheet 427-105 for details.
- ⑥ Minimum bore is the smallest bore to which a Rough Stock Bore (RSB) hub can be bored. Depending upon coupling size, RSB hubs may have only a blind centering hole or a through hole that will permit remachining of the hubs to the minimum bores specified.

Engineering Data

Table 13 — Shaft Diameters & Ratings for NEMA 60 Hertz & 50 Hertz Metric Motors

Frame Size		NEMA 60 Hertz Motors (HP)																											
		T Frames																TS Frames											
Shaft Dia (in)		143	145	182	184	213	215	254	256	284	286	324	326	364	365	404	405	444	445	284	286	324	326	364	365	404	405	444	445
3600 RPM	Drip Proof	1-1/2	2-3	5	7-1/2	10	15	20	25	30	40	50	60	75	100	125	150	200	250	30	40	50	60	75	100	125	150	200	250
	Enclosed	1-1/2	2	3	5	7-1/2	10	15	20	25	30	40	50	60	75	—	100	125	150	25	30	40	50	60	75	—	100	125	150
1800 RPM	Drip Proof	1	1-1/2, 2	3	5	7-1/2	10	15	20	25	30	40	50	60	75	100	125	150	200	25	30	40	50	60	75	100	125	150	200
	Enclosed	1	1-1/2, 2	3	5	7-1/2	10	15	20	25	30	40	50	60	75	—	100	125	150	25	30	40	50	60	75	—	100	125	150
1200 RPM	Drip Proof & Enclosed	3/4	1	1-1/2	2	3	5	7-1/2	10	15	20	25	30	40	50	60	75	100	125	15	20	25	30	40	50	60	75	100	125
900 RPM	Drip Proof & Enclosed	1/2	3/4	1	1-1/2	2	3	5	7-1/2	10	15	20	25	30	40	50	60	75	100	10	15	20	25	30	40	50	60	75	100

Frame Size		50 Hertz Metric Motors (kW)																	
		80	90S	90L	100L	112M	132S	132M	160M	160L	180M	180L	200M/L	225S	225M	250S	250M	280S	280M
Shaft Dia (mm)		19	24	24	28	28	38	38	42	42	48	48	55	55 60	55 60	60, 65 70	60, 65 70	65, 75 80	65, 75 80
3000 RPM		0.75 1.10	1.5	2.2	3.0	4	5.5 7.5	—	11 15	18.5	22	—	30 37	45	45	55	55 75	75 90	90 110
1500 RPM		0.55 0.75	1.1	1.5	2.2 3.0	4	5.5	7.5	11	15	18.5	22	30	37 45	45	55	55 75	75 90	90 110
1000 RPM		0.37 0.55	0.75	1.1	1.5	2.2	3	4 5.5	7.5	11	—	15	18.5 22	30	30	37	37 45	45 45	55 75
750 RPM		0.18 0.25	0.37	0.55	0.75 1.1	1.5	2.2	3	4 5.5	7.5	—	11	15	18.5	22	30	30 37	37 45	45 55

OVERHANGING HUBS — Hubs may be overhung on the shafting, provided there is more than one shaft diameter of hub/shaft engagement for clearance fits, or more than 0.75 times shaft diameter hub/shaft engagement for interference fits. If hub engagement is less than what is required, use a standard long hub listed in **Table 22** on **page 39**, or submit application details to the Factory.

Dimension L must be equal to or greater than Dimension SD for clearance fits, or greater than Dimension SD times 0.75 for interference fits. For Type T63, Dimension Y must be equal to or greater than Dimension X.

Example: SD = 4"; then L must be 4" or more for clearance fits or 3" or more for interference fits.

CAUTION: The effect of open keyways on coupling balance should be accounted for.

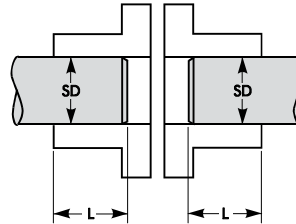

Example – Type T, Other than T63

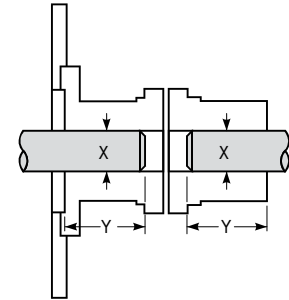

Example – Type T63

Engineering Data

Table 14 — Type T Hub & Flanged Hub Bore Ranges with Square & Rectangular Keys ③

Size ①	Min Bore ⑧	Inches														Millimeters ⑤				
		For One Square Key				For One Rectangular Key						For Two Square Keys			For Two Rectangular Keys			Min Bore	Max Bore	
		Max Bore ⑨	Y=X		Max Bore ⑨	Y=X		Max Bore ⑨	Y=W/2 ④		Max Bore ⑨	Y=X		Max Bore ⑨	Y=X		Std Bore Fits per Table 30 ⑥		Int Fit per Table 30 w/ Setscrew Over Keyway	
			W	Y		W	Y		W	Y		W	Y							
20/1020T	0.500	1.125 ②	0.250 ②	0.125 ②	1.187	0.250	0.093	1.250	0.250	0.062	—	—	—	—	—	—	13	28	24	
30/1030T	0.500	1.375 ②	0.312 ②	0.156 ②	1.437	0.375	0.125	1.562	0.375	0.062	—	—	—	—	—	—	13	35	30	
40/1040T	0.500	1.625 ②	0.375 ②	0.187 ②	1.750	0.375	0.125	1.750	0.375	0.062	—	—	—	—	—	—	13	43	38	
50/1050T	0.500	1.875 ②	0.500 ②	0.250 ②	2.000	0.500	0.187	2.125	0.500	0.125	—	—	—	—	—	—	13	50	45	
60/1060T	0.750	2.125 ②	0.500 ②	0.250 ②	2.250	0.500	0.187	2.375	0.625	0.125	—	—	—	—	—	—	20	56	50	
70/1070T	0.750	2.500 ②	0.625 ②	0.312 ②	2.687	0.625	0.218	2.875	0.750	0.125	—	—	—	—	—	—	20	67	60	
80/1080T	1.062	3.000 ②	0.750 ②	0.375 ②	3.250	0.750	0.250	3.375	0.875	0.187	—	—	—	—	—	—	27	80	75	
90/1090T	1.062	3.500 ②	0.875 ②	0.437 ②	3.750	0.875	0.312	3.875	1.000	0.250	—	—	—	—	—	—	27	95	90	
100/1100T	1.625	4.000 ②	1.000 ②	0.500 ②	4.250	1.000	0.375	4.500	1.000	0.250	—	—	—	—	—	—	42	110	100	
110/1110T	1.625	4.500 ②	1.000 ②	0.500 ②	4.625	1.250	0.437	5.000	1.250	0.250	—	—	—	—	—	—	42	120	110	
120/1120T	2.375	5.000 ②	1.250 ②	0.625 ②	5.375	1.250	0.437	5.750	1.500	0.250	—	—	—	—	—	—	61	140	120	
130/1130T	2.625	6.000 ②	1.500 ②	0.750 ②	6.500	1.500	0.500	6.500	1.500	0.250	—	—	—	—	—	—	67	170	150	
140/1140T	2.625	7.000	1.750	0.875	7.250 ②	1.750 ②	0.750 ②	7.750	2.000	0.500	—	—	—	—	—	—	67	200	180	
150/1150T	4.250	7.500	1.750	0.875	8.000 ②	2.000 ②	0.750 ②	—	—	—	—	—	—	—	—	—	108	215	190	
160/1160T	4.750	8.500	2.000	1.000	9.000 ②	2.000 ②	0.750 ②	—	—	—	—	—	—	—	—	—	121	240	215	
1170T	5.250	9.750	2.500	1.250	10.000 ②	2.500 ②	0.875 ②	—	—	—	10.750	1.750	0.875	11.000	1.750	0.750	134	280	240	
1180T	6.000	10.750	2.500	1.250	11.000 ②	2.500 ②	0.875 ②	—	—	—	12.000	1.750	0.875	12.250	2.000	0.750	153	300	260	
1190T	6.000	11.750	3.000	1.500	12.000 ②	3.000 ②	1.000 ②	—	—	—	13.000	2.000	1.000	13.250	2.000	0.750	153	336	290	
1200T	7.000	12.750	3.000	1.500	13.000 ②	3.000 ②	1.000 ②	—	—	—	14.000	2.500	1.250	14.250	2.500	0.875	178	360	320	
1210T	7.000	13.750	3.500	1.750	14.000 ②	3.500 ②	1.250 ②	—	—	—	15.000	2.500	1.250	15.250	2.500	0.875	178	390	350	
1220T	8.000	14.750	3.500	1.750	15.000 ②	3.500 ②	1.250 ②	—	—	—	16.000	2.500	1.250	16.250	3.000	1.000	178	420	380	
1230T	8.000	15.750	4.000	2.000	16.000 ②	4.000 ②	1.500 ②	—	—	—	17.000	3.000	1.500	17.250	3.000	1.000	254	450	410	
1240T	10.000	16.750	4.000	2.000	17.000 ②	4.000 ②	1.500 ②	—	—	—	18.000	3.000	1.500	18.250	3.000	1.000	254	480	440	
1250T	10.000	18.000	4.000	2.000	18.500 ②	5.000 ②	1.750 ②	—	—	—	19.250	3.500	1.750	19.750	3.500	1.250 ⑦	⑦	⑦	⑦	
1260T	10.000	19.500	5.000	2.500	20.000 ②	5.000 ②	1.750 ②	—	—	—	20.750	3.500	1.750	21.250	3.500	1.250 ⑦	⑦	⑦	⑦	

Table 15 — Type T31& T35 Shaft Hub Bore Ranges with Square & Rectangular Keys ③

Size ①	Min Bore ⑧	Inches									Millimeters			
		For One Square Key			For One Rectangular Key						Min Bore	Max Bore		
		Max Bore ⑨	Y=X		Max Bore ⑨	Y=X		Max Bore ⑨	Y=W/2 ④			Std Bore Fits per Table 30	Int Fit per Table 30 w/Setscrew Over Keyway	With Puller Holes per Table 23 or Table 24
			W	Y		W	Y		W	Y				
1020T	0.500	1.375 ②	0.312 ②	0.156 ②	1.437	0.375	0.125	1.562	0.375	0.062	13	35	30	35
1030T	0.500	1.625 ②	0.375 ②	0.188 ②	1.750	0.375	0.125	—	—	—	13	43	38	43
1040T	0.500	2.125 ②	0.500 ②	0.250 ②	2.250	0.500	0.188	2.375	0.625	0.125	13	56	50	56
1050T	0.500	2.375 ②	0.625 ②	0.312 ②	2.500	0.625	0.218	2.625	0.625	0.125	13	67	60	67
1060T	0.750	2.875 ②	0.750 ②	0.375 ②	3.125	0.750	0.250	3.250	0.750	0.125	20	80	76	80
1070T	0.750	3.125 ②	0.750 ②	0.375 ②	3.250	0.750	0.250	3.375	0.875	0.188	20	85	80	85
1080T	1.062	3.500 ②	0.875 ②	0.438 ②	3.750	0.875	0.312	3.875	1.000	0.250	27	95	90	88
1090T	1.062	4.000 ②	1.000 ②	0.500 ②	4.250	1.000	0.375	4.500	1.000	0.250	27	110	100	100
1100T	1.500	4.750 ②	1.250 ②	0.625 ②	5.000	1.250	0.438	5.250	1.250	0.250	39	130	120	120
1110T	2.000	5.500 ②	1.250 ②	0.625 ②	5.875	1.500	0.500	6.250	1.500	0.250	51	150	140	140
1120T	2.500	6.250 ②	1.500 ②	0.750 ②	6.500	1.500	0.500	6.750	1.750	0.625	64	170	165	160
1130T	3.000	6.750	1.750	0.875	7.000 ②	1.750 ②	0.750 ②	7.250	1.750	0.625	77	190	180	175
1140T	3.500	7.500	2.000	1.000	8.000 ②	2.000 ②	0.750 ②	8.500	2.000	0.500	89	210	200	200
1150T	4.000	9.750	2.000	1.000	10.000 ②	2.500 ②	0.875 ②	—	—	—	102	270	230	250
1160T	4.500	10.500	2.500	1.250	11.000 ②	2.500 ②	0.875 ②	—	—	—	115	290	260	280
1170T	5.000	12.000	3.000	1.500	13.000 ②	3.000 ②	1.000 ②	—	—	—	127	340	290	330
1180T	4.000	12.000	3.000	1.500	13.000 ②	3.000 ②	1.000 ②	—	—	—	102	340	310	340
1190T	4.500	13.250	3.500	1.750	14.250 ②	3.500 ②	1.250 ②	—	—	—	116	380	340	380
1200T	5.000	14.250	3.500	1.750	15.000 ②	3.500 ②	1.250 ②	—	—	—	127	400	365	400

- ① Refer to page 10 for general information.
- Metric keyways and keyway radiuses will be furnished per ISO/R773 (DIN 6885/1) and Js9 width tolerances unless otherwise specified. P9 and D10 width tolerance can be furnished on request. Refer to 427-140 for tolerances.
- ② Shaded areas indicate maximum bores using standard recommended keys shown in Table 26.
- ③ Unless otherwise specified, Sizes 1020 thru 1090 will be furnished for clearance fit with a setscrew over the keyway and Sizes 1100 and larger will be furnished for interference fit without a setscrew. Exception: For Types T50 and T70, coupling hubs are normally furnished with an average interference fit of 0.0005" per inch of shaft diameter. Clearance fit and/or hubs with setscrews are not recommended.
- ④ Shaft keyway depth Y equals one-half of square key W. **NOTE:** Check key stresses.
- ⑤ Also applies to Hub Type T61, T63, T50 pilot hub and flanged hub of T50 and T70 type couplings.
- ⑥ With standard puller bolt holes per Table 23, page 39.
- ⑦ Consult Rexnord.
- ⑧ Minimum bore is the smallest bore to which a Rough Stock Bore (RSB) hub can be bored. Depending upon coupling size, RSB hubs may have only a blind centering hole or a through hole that will permit remachining of the hubs to the minimum bores specified.
- ⑨ Maximum bores are reduced for hubs furnished with an interference fit and a setscrew over the keyway. Refer to Rexnord Engineering Sheet 427-105 for details.

Engineering Data

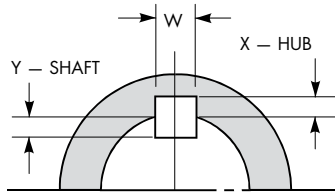

CHECK KEY STRESSES

Table 16 — T41 Hub Bore Ranges with Square and Rectangular Keys

Size ①	Inches								Millimeters		
	Min Bore ⑥	For One Square Key			For One Rectangular Key				Min Bore	Max Bore	
		Max Bore ⑦	Y=X		Max Bore ⑦	W	X	Y		Std Bore Fits per Table 30	Int Fit per Table 30 w/ Setscrew Over Keyway
W	X										
1020T41	0.500	1.000 ④	0.250	0.125	1.125	0.250	0.062	0.125	13	24 ⑤	⑤
1030T41	0.500	1.250 ④	0.250	0.125	1.375	0.312	0.093	0.156	13	32	⑤
1040T41	0.500	1.375 ④	0.312	0.156	1.625	0.375	0.062	0.187	13	38	32
1050T41	0.500	1.750 ④	0.375	0.187	1.875	0.500	0.125	0.250	13	45	40
1060T41	0.750	1.875 ④	0.500	0.250	2.125	0.500	0.125	0.250	20	50	45
1070T41	0.750	2.250 ④	0.500	0.250	2.500	0.625	0.125	0.312	20	60	50
1080T41	1.062	2.625 ④	0.625	0.312	2.750	0.625	0.125	0.312	27	70	65
					3.000	0.750	0.125	0.375	27	70	65
1090T41	1.062	3.125 ④	0.750	0.375	3.250	0.750	0.125	0.375	27	85	80
					3.500	0.875	0.187	0.437	27	85	80
1100T41	1.625	3.625 ④	0.875	0.437	3.750	0.875	0.187	0.437	42	100	90
					4.000	1.000	0.250	0.500	42	100	90
1110T41	1.625	4.000 ④	1.000	0.500	4.500	1.000	0.250	0.500	42	110	100
1120T41	2.375	4.500 ④	1.000	0.500	5.000	1.250	0.250	0.625	61	120	110
1130T41	2.625	5.250 ④	1.250	0.625	5.500	1.250	0.250	0.625	67	145	135
					6.000	1.500	0.250	0.750	67	145	135
1140T41	2.625	6.500 ④	1.500	0.750	7.250 ③	1.750	0.500	0.750	67	180	165
					7.000 ④	1.750	0.750	0.750	108	190	180
1150T41	4.250	6.750 ②	1.750	0.875	7.500 ③	1.750	0.500	0.750	108	190	180
					8.000 ③	2.000	0.375	0.750	108	190	180
1160T41	4.750	7.750 ②	2.000	1.000	8.500 ④	2.000	0.750	0.750	121	225	200
					9.000 ③	2.000	0.500	0.750	121	225	200
1170T41	5.250	9.000 ②	2.000	1.000	9.500 ④	2.500	0.875	0.875	134	250	230
					10.000 ③	2.500	0.500	0.875	134	250	230
1180T41	6.000	10.250 ②	2.500	1.250	11.000 ④	2.500	0.875	0.875	153	290	260
1190T41	6.000	11.000 ②	2.500	1.250	12.000 ④	3.000	1.000	1.000	153	320	285
1200T41	7.000	12.125 ②	3.000	1.500	13.000 ④	3.000	1.000	1.000	178	340	310

Table 17 — Type G82 Hub (used on T10/G82 assemblies) Bore Ranges with Square & Rectangular Keys

Size ①	Min Bore ⑥	Inches						Millimeters			
		For One Square Key			For One Rectangular Key			Min Bore	Max Bore		
		Max Bore ⑦	Y=X		Max Bore ⑦	Y=X			Std Bore Fits per Table 30	Int Fit per Table 30 w/ Setscrew Over Keyway	With Puller Holes per Table 24
W	X		W	X							
1035G	2.000 ④	5.875 ④	1.500 ④	0.750 ④	6.500	1.500	0.500	51	163	150	150
1040G	2.500	6.750	1.750	0.875	7.250 ④	1.750 ④	0.750 ④	64	196	167	185
1045G	3.000	7.625	1.750	0.875	8.125 ④	2.000 ④	0.750 ④	77	216	190	205
1050G	3.500	8.750	2.000	1.000	9.000 ④	2.000 ④	0.750 ④	89	235	220	228
1055G	4.000	9.750	2.000	1.000	10.000 ④	2.500 ④	0.875 ④	102	266	230	250
1060G	4.500	10.500	2.500	1.250	11.000 ④	2.500 ④	0.875 ④	115	290	260	280
1070G	5.000	12.000	3.000	1.500	13.000 ④	3.000 ④	1.000 ④	127	340	290	330
1080G	4.000	13.000	3.000	1.500	13.250 ④	3.000 ④	1.000 ④	102	340	310	340
1090G	4.500	14.250	3.500	1.750	15.000 ④	3.500 ④	1.250 ④	115	380	340	380
1100G	5.000	15.000	3.500	1.750	15.500 ④	3.500 ④	1.250 ④	127	400	365	400

- ① Refer to page 10 for General Information. Unless otherwise specified, Sizes 1020 thru 1090 will be furnished for clearance fit with a setscrew over the keyway and Sizes 1100 and larger will be furnished for interference fit without a setscrew.
- ② Maximum bore with optional square key.
- ③ A special rectangular key is required.
- ④ Maximum bores using standard recommended keys shown in Table 26.
- ⑤ Interference fit is not recommended.
- ⑥ Minimum bore is the smallest bore to which a Rough Stock Bore (RSB) hub can be bored. Depending upon coupling size, RSB hubs may have only a blind centering hole or a through hole that will permit remachining of the hubs to the minimum bores specified.
- ⑦ Maximum bores are reduced for hubs furnished with an interference fit and a setscrew over the keyway. Refer to Rexnord Engineering Sheet 427-105 for details.

Engineering Data

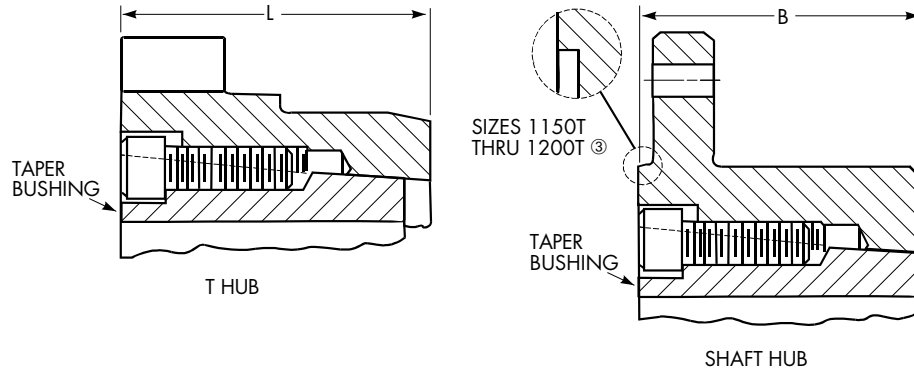

Table 18 — Taper-Lock Bushings for Type T Hubs & Shaft Hubs ①

Coupling Size	T Hub				Shaft Hub				
	Bushing Number	Bore Range ② (in)	Torque (lb-in)	L (in)	Bushing Number	Bore Range ② (in)	Torque (lb-in)	B (in)	Gear Cplg Rigid Hub Size
1020T	—	—	—	—	1108	0.500 to 1.125	460	1.38	—
1030T	1108	0.500 to 1.125	1,300	1.62	1108	0.500 to 1.125	1,300	1.62	—
1040T	1108	0.500 to 1.125	1,300	1.62	1310	0.500 to 1.375	2,200	2.12	—
1050T	1215	0.500 to 1.250	3,550	1.88	1615	0.500 to 1.625	3,850	2.38	—
1060T	1615	0.500 to 1.625	4,300	2.12	2012	0.500 to 2.000	6,500	2.88	—
1070T	2012	0.500 to 2.000	7,150	2.12	2525	0.750 to 2.500	8,800	3.12	—
1080T	2525	0.750 to 2.500	11,300	2.62	2525	0.750 to 2.500	11,300	3.50	—
1090T	3030	0.938 to 3.000	24,000	3.12	3030	0.938 to 3.000	24,000	4.00	—
1100T	3030	0.938 to 3.000	24,000	3.50	3535	1.188 to 3.500	48,800	3.56	—
1110T	3535	1.188 to 3.500	44,800	3.62	4040	1.438 to 4.000	77,300	4.10	—
1120T	4040	1.438 to 4.000	77,300	4.38	4545	1.938 to 4.500	110,000	4.70	—
1130T	4545	1.938 to 4.500	110,000	4.62	5050	2.438 to 5.000	126,000	5.30	—
1140T	5050	2.438 to 5.000	126,000	5.12	5050	2.438 to 5.000	126,000	6.00	—
1150T	5050	2.438 to 5.000	126,000	7.20	6050	3.438 to 6.000	282,000	6.80 ③	1055
1160T	5050	2.438 to 5.000	126,000	7.80	7060	3.938 to 7.000	416,000	7.34 ③	1060
1170T	7060	3.938 to 7.000	416,000	8.50	8065	4.438 to 8.000	456,000	8.67 ③	1070
1180T	8065	4.438 to 8.000	456,000	9.40	8065	4.438 to 8.000	456,000	9.80 ③	1080
1190T	8065	4.438 to 8.000	456,000	10.20	10085	7.000 to 10.000	869,000	10.86 ③	1090
1200T	10085	7.000 to 10.000	869,000	11.00	10085	7.000 to 10.000	869,000	12.00 ③	1100

① Use straight bored hubs for shock load or reversing load applications or applications that require 1.75 or higher coupling service factors or refer to the Factory for selection, price and delivery of special bushings. Refer to Factory for selection of Taper-Lock bushings for Type T50 and T70 couplings.

② Bushings require shaft keyways as calculated in **Table 26**.

③ For Sizes 1150T thru 1200T, dimension "B" is to the hub counterbore.

Engineering Data

Table 19 — WR² Values (lb-in²)

(WR² values are based on hubs with no bore; seals, lube plugs and gaskets are not considered.)

Coupling Size	Coupling Type											T70	
	T10	T20	T31		T35		T10/G82 ①			T50			
			WR ² (Min BE)	WR ² Added per Inch of BE Over Minimum	WR ² (Min BE)	WR ² Added per Inch of BE Over Minimum	Rigid Hub Size	WR ² (Without Shaft)	WR ² Added per Inch of Length of "SD" Diameter Between Hubs	WR ² (Each Coupling)	WR ² Added per Inch of Length of "SD" Diameter Between Hubs		
1020T	4.83	5.32	9.8	0.18	7.3	0.18	—	—	—	—	—	—	—
1030T	7.61	7.99	15.3	0.42	11.5	0.42	—	—	—	—	14.8	0.043	14.8
1040T	11.19	11.99	31.8	0.76	21.5	0.76	—	—	—	—	—	—	—
1050T	24.85	25.76	62.0	1.40	43.4	1.40	—	—	—	—	61.7	0.14	61.7
1060T	40.66	41.16	132	2.38	86.4	2.38	—	—	—	—	—	—	—
1070T	63.18	61.68	175	4.06	119	4.06	—	—	—	—	144	0.44	144
1080T	154	148	396	8.37	275	8.37	—	—	—	—	346	1.08	346
1090T	269	272	805	16.2	537	16.2	—	—	—	—	603	2.24	603
1100T	609	608	1,756	27.2	1,183	27.2	—	—	—	—	1,424	5.46	1,424
1110T	923	930	2,726	45.4	1,825	45.4	1035G	2,688	11.3	2,384	7.95	2,383	
1120T	1,755	1,611	5,341	70.9	3,548	70.9	1040G	5,155	17.3	2,734	14.1	2,733	
1130T	3,378	3,568	8,563	153	5,970	153	1045G	8,738	35.8	4,854	23.1	4,852	
1140T	6,306	6,431	14,871	283	10,588	283	1050G	16,346	76.3	9,575	30.2	9,572	
1150T	11,922	11,243	30,740	237	21,331	237	1055G	28,112	113	10,390	49.3	—	
1160T	19,876	20,597	43,610	394	31,773	394	1060G	41,251	181	31,150	113	—	
1170T	35,621	35,625	84,639	789	60,130	789	1070G	80,916	276	51,140	113	—	
1180T	62,553	—	135,817	1,197	99,185	1,197	1080G	130,917	404	88,040	181	—	
1190T	89,359	—	222,003	1,856	155,681	1,856	1090G	212,411	572	125,920	276	—	
1200T	148,676	—	319,363	3,306	234,019	3,306	1100G	316,614	788	204,240	404	—	
1210T	257,900	—	—	—	—	—	—	—	—	—	—	—	
1220T	385,696	—	—	—	—	—	—	—	—	—	—	—	
1230T	597,136	—	—	—	—	—	—	—	—	—	—	—	
1240T	1,157,844	—	—	—	—	—	—	—	—	—	—	—	
1250T	1,791,120	—	—	—	—	—	—	—	—	—	—	—	
1260T	2,428,359	—	—	—	—	—	—	—	—	—	—	—	

① Values shown are for standard hub lengths.

Coupling Misalignment

Maximum life and minimum maintenance for the coupling and connected machinery will result if couplings are accurately aligned. Coupling life expectancy between initial alignment and maximum operating limits is a function of load, speed and lubrication. For applications requiring greater misalignment, refer application details to Rexnord.

Angular misalignment is expressed in degrees and as the difference between the value of X minus Y, as illustrated.

Parallel misalignment is the distance P between shaft center lines as shown.

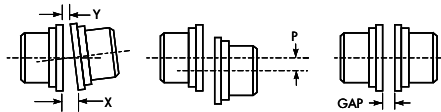

Table 20 — Misalignment Capacity (in) ②

Cplg Size	Recommended Installation Maximum			Maximum Operating				Normal Gap ± 10%	
	Parallel Offset – P			Angular (1/16°) X Minus Y	Parallel Offset – P Inches ③		Angular (1/4°) X Minus Y	All Types Except T31	Type T31
	Types T10, T20, T31, T35, T41, T63	Type T50	Type T70		Types T10, T20, T31, T35, T41, T63	Type T70			
20/1020T	0.006	—	—	0.003	0.012	—	0.010	0.125	0.188
30/1030T	0.006	0.002	0.003	0.003	0.012	0.006	0.012	0.125	0.188
40/1040T	0.006	—	—	0.003	0.012	—	0.013	0.125	0.188
50/1050T	0.008	0.002	0.004	0.004	0.016	0.008	0.016	0.125	0.188
60/1060T	0.008	—	—	0.005	0.016	—	0.018	0.125	0.188
70/1070T	0.008	0.002	0.004	0.005	0.016	0.008	0.020	0.125	0.188
80/1080T	0.008	0.002	0.004	0.006	0.016	0.008	0.024	0.125	0.188
90/1090T	0.008	0.003	0.004	0.007	0.016	0.008	0.028	0.125	0.188
100/1100T	0.010	0.003	0.005	0.008	0.020	0.010	0.033	0.188	0.250
110/1110T	0.010	0.003	0.005	0.009	0.020	0.010	0.036	0.188	0.250
120/1120T	0.011	0.003	0.006	0.010	0.022	0.011	0.040	0.250	0.375
130/1130T	0.011	0.004	0.006	0.012	0.022	0.011	0.047	0.250	0.375
140/1140T	0.011	0.004	0.006	0.013	0.022	0.011	0.053	0.250	0.375
150/1150T	0.012	0.004	0.006	0.016	0.024	0.012	0.062	0.250	0.375
160/1160T	0.012	0.005	0.006	0.018	0.024	0.012	0.070	0.250	0.375
170/1170T	0.012	0.005	0.006	0.020	0.024	0.012	0.079	0.250	0.375
180/1180T	0.015	0.005	0.008	0.022	0.030	0.015	0.089	0.250	0.375
190/1190T	0.015	0.006	0.008	0.024	0.030	0.015	0.097	0.250	0.375
200/1200T	0.015	0.006	0.008	0.027	0.030	0.015	0.107	0.250	0.375
1210T	0.018	—	—	0.029	0.036	—	0.118	0.500	—
1220T	0.018	—	—	0.032	0.036	—	0.129	0.500	—
1230T	0.019	—	—	0.035	0.038	—	0.142	0.500	—
1240T	0.019	—	—	0.038	0.038	—	0.154	0.500	—
1250T	0.020	—	—	0.042	0.040	—	0.169	0.500	—
1260T	0.020	—	—	0.046	0.040	—	0.183	0.500	—

② Values may be combined for an installation or an operating condition.

③ Operating offset limits between Type T50 floating shaft assembly is a function of 1/4° and distance between shaft ends.

Engineering Data

Mill Motor and Taper Bore Dimensions — Inches

Standardized for AISE mill motors. Also available for use on other tapered shaft applications such as large pumps, compressors and turbines.

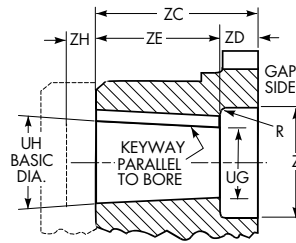

Type T Hub or T31/T35 Shaft Hubs Only

Table 21 — Standard AISE AC & DC Mill Motor Coupling Selections

Motor Frame Sizes			Cplg Size ①	R	Z	UG	UH	Keyway	ZC	ZD	ZE	ZH +.XXX -.000
2 602	802 A, B & C	AC 1, 2 & 4	1060T	0.12	2.625							
			1070T	0.12	2.625							
			1080T	0.31	3.500	1.437	1.750	0.500 x 0.250	3.94	0.94	3.00	.024
			1090T	0.31	3.500							
			1100T	0.31	3.500							
603 604	803 804	—	1070T	0.12	3.000							
			1080T	0.38	4.000	1.635	2.000	0.500 x 0.250	4.50	1.00	3.50	.029
			1090T	0.38	4.000							
			1100T	0.38	4.000							
606	806	AC 8 & 12	1080T	0.12	3.500							
			1090T	0.38	4.500	2.083	2.500	0.500 x 0.250	5.12	1.12	4.00	.029
			1100T	0.38	4.500							
			1110T	0.38	4.500							
608	808	—	1090T	0.12	4.375							
			1100T	0.50	5.375	2.531	3.000	0.750 x 0.250	5.75	1.25	4.50	.029
			1110T	0.50	5.375							
			1120T	0.50	5.375							
610	810	AC18	1100T	0.12	5.000							
			1110T	0.50	6.000	2.781	3.250	0.750 x 0.250	5.88	1.38	4.50	.034
			1120T	0.50	6.000							
			1130T	0.50	6.000							
612	812	AC 25 & 30	1100T	0.12	5.250							
			1110T	0.12	5.250							
			1120T	0.12	6.250	3.104	3.625	0.750 x 0.250	6.50	1.50	5.00	.034
			1130T	0.12	6.250							
			1140T	0.12	6.250							
614	814	AC 40 & 50	1110T	0.12	5.875							
			1120T	0.12	5.875							
			1130T	0.50	6.750	3.729	4.250	1.000 x 0.375	6.62	1.62	5.00	.034
			1140T	0.50	6.750							
616	816	—	1120T	0.12	6.500							
			1130T	0.62	8.000	4.052	4.625	1.250 x 0.375	7.25	1.75	5.50	.034
			1140T	0.62	8.000							
618	818	—	1130T	0.12	7.000							
			1140T	0.62	8.500	4.375	5.000	1.250 x 0.500	7.31	1.31	6.00	.038
			1150T	0.62	8.500		4.994		7.25	5.94		
620	—	—	1140T	0.25	8.750							
			1150T	0.75	9.750	5.172	5.740	1.500 x 0.750	8.03	1.75	5.45	.038
			1160T	0.75	9.750		5.802		7.80	6.05		
622	—	—	1140T	0.25	8.750							
			1150T	0.75	9.750		6.083		8.03	5.65		
			1160T	0.75	9.750	5.495	5.997	1.500 x 0.750	7.20	2.38	4.82	.038
			1170T	0.75	9.750		6.059		7.80	5.42		
624	—	—	1140T	0.25	8.750							
			1150T	0.75	9.750		6.625		8.03	5.65		
			1160T	0.75	9.750		6.539		7.20	4.82		
			1170T	0.75	9.750	6.037	6.601	1.500 x 0.750	7.80	2.38	5.42	.038
			1180T	0.75	9.750		6.674		8.50	6.12		
			1190T	0.75	9.750		6.768		7.40	7.02		

① Coupling selections are based on coupling bore capacity and standard available hub lengths. Check coupling rating for all selections, and hub key stress for mill motor selections 620 and larger.

Engineering Data

Table 22 specifies the taper and counter bore limitations for the usual requirements. Refer applications for counter bore diameters or depths which exceed any of these limitations, and requirements for hubs longer than those listed, to Rexnord with full particulars for review.

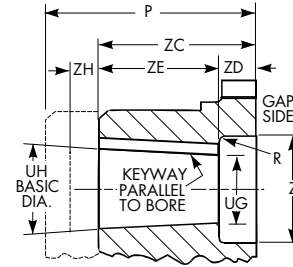

Type T Hub or T31/T35 Shaft Hubs Only ①

Table 22 — Taper & Counter Bore Limitations ①

Size	Std Long Hub Length L & P Max ②	R	Z Max	UG Min	UH Max	ZD Max	Keyway ③
20/1020T	3.88	0.12	1.438	0.500	1.125	0.62	0.250 x 0.125
30/1030T	4.12	0.12	1.812	0.500	1.375	0.62	0.312 x 0.156
40/1040T	4.12	0.12	2.125	0.500	1.625	0.62	0.375 x 0.188
50/1050T	6.50	0.25	2.562	0.500	1.875	0.81	0.500 x 0.250
60/1060T	6.59	0.25	2.875	0.750	2.125	0.81	0.500 x 0.250
70/1070T	6.59	0.25	3.312	0.750	2.500	0.88	0.625 x 0.312
80/1080T	8.09	0.38	4.062	1.062	3.000	1.25	0.750 x 0.375
90/1090T	8.09	0.38	4.625	1.062	3.500	1.38	0.875 x 0.438
100/1100T	8.06	0.50	5.375	1.625	4.000	1.69	1.000 x 0.500
110/1110T	8.06	0.50	6.000	1.625	4.500	1.75	1.000 x 0.500
120/1120T	8.03	0.62	6.500	2.375	5.000	2.00	1.250 x 0.625
130/1130T	8.03	0.62	8.000	2.625	6.000	2.06	1.500 x 0.750
140/1140T	8.03	0.75	9.250	2.625	7.000	2.25	1.750 x 0.625
150/1150T	7.20	0.75	10.500	4.250	8.000	2.50	2.000 x 0.750
160/1160T	7.80	0.75	12.000	4.750	9.000	2.75	2.000 x 0.750
1170T	8.50	0.75	14.000	5.250	10.000	3.00	2.500 x 0.875

Table 23 — Type T Steelflex Coupling Puller Bolt Holes (in)

Size	T-Hub		Shaft Hub	
	B.C.	Tap Size – UNC	B.C. ④	Tap Size – UNC
1020T	1.531	#6-32 x 0.38	2.812	0.375-16 x ⑤
1030T	1.875	#6-32 x 0.38	3.125	0.375-16 x ⑤
1040T	2.125	#10-24 x 0.38	3.875	0.375-16 x ⑤
1050T	2.500	#10-24 x 0.38	4.250	0.375-16 x ⑤
1060T	2.875	0.250-20 x 0.38	4.938	0.375-16 x ⑤
1070T	3.312	0.250-20 x 0.38	5.250	0.375-16 x ⑤
1080T	3.937	0.250-20 x 0.38	4.062	0.375-16 x .50
1090T	4.562	0.3125-18 x 0.44	4.625	0.375-16 x 0.50
1100T	5.250	0.375-16 x 0.50	5.750	0.625-11 x 0.82
1110T	5.875	0.4375-14 x 0.62	6.562	0.625-11 x 0.82
1120T	6.625	0.4375-14 x 0.62	7.500	0.750-10 x 0.94
1130T	7.750	0.625-11 x 0.82	8.188	0.750-10 x 0.94
1140T	9.125	0.625-11 x 0.82	9.250	0.750-10 x 0.94
1150T	10.375	0.750-10 x 0.94	—	—
1160T	11.750	0.875-9 x 1.06	—	—
1170T	13.250	1.125-7 x 1.25	—	—
1180T	14.875	1.250-7 x 1.50	—	—
1190T	16.250	1.500-6 x 1.75	—	—
1200T	17.937	1.500-6 x 1.75	—	—
1210T	19.562	1.500-6 x 1.75	—	—
1220T	21.312	1.500-6 x 1.75	—	—
1230T	23.062	1.500-6 x 1.75	—	—
1240T	24.938	1.500-6 x 1.75	—	—
1250T	27.188	1.500-6 x 1.75	—	—
1260T	29.500	1.500-6 x 1.75	—	—

① Refer to Rexnord for other hubs.

② Standard long hub length available for Type T Hubs and flanged hubs; consult Factory for longer lengths.

③ Keyway shown is for maximum bore.

④ Locate puller bolt holes 90° from keyway except as noted by Footnote ⑤.

⑤ Drill and tap thru flange between existing holes. Relation to keyway may vary freely.

⑥ See **page 10** for General Information.

⑦ 1000T series information also applies to 10T series, e.g., 1020=20.

⑧ Also applies to hub Types T61, T63, T50 pilot hub and flanged hub of Types T50 & T70 couplings.

⑨ Interference fit is not recommended.

Table 24 — Type G Gear Coupling Rigid Hub Puller Bolt Holes (in)

Size ⑥	B.C. Rigid Hub	Tap Size UNC
1035G	7.180	0.500-13 x 0.62
1040G	8.260	0.625-11 x 0.75
1045G	9.180	0.625-11 x 0.75
1050G	10.200	0.750-10 x 0.88
1055G	11.200	0.750-10 x 0.88
1060G	12.460	0.750-10 x 0.88
1070G	14.500	1.000-8 x 1.18
1080G	15.750	1.000-8 x 1.18
1090G	18.000	1.250-7 x 1.50
1100G	18.562	1.500-6 x 1.75
1110G	20.500	1.500-6 x 1.75

Table 25 — Reduced Max Bores Interference Fit & Setscrew Over Keyway — All Type T Couplings

Size ⑦	T ⑧	T41 Hub	Shaft Hub for T31 & T35
1020T	1.000	⑨	1.250
1030T	1.250	⑨	1.500
1040T	1.375	1.250	2.000
1050T	1.750	1.500	2.125
1060T	1.875	1.750	2.750
1070T	2.250	2.125	2.875
1080T	2.750	2.375	3.250
1090T	3.250	2.875	3.750
1100T	3.500	3.250	4.500
1110T	4.000	3.750	5.000
1120T	4.500	4.250	6.000
1130T	5.500	5.000	6.500
1140T	6.500	5.875	7.500
1150T	7.000	6.500	8.750
1160T	8.000	7.500	9.750
1170T	9.000	8.875	11.000
1180T	9.750	9.750	11.750
1190T	10.750	10.750	13.000
1200T	11.750	11.750	13.500

Engineering Data

Table 26 — Recommended Commercial Keys for Bores with One Key (in/mm)

Inches (Per ANSI B17.1 Standard)											
Shaft Dia		Key	Shaft Dia		Key	Shaft Dia		Key	Shaft Dia		Key
Over	Through		Over	Through		Over	Through		Over	Through	
0.438	0.562	0.125 x 0.125	1.750	2.250	0.500 x 0.500	4.500	5.500	1.250 x 1.250	11.000	13.000	3.000 x 2.000
0.562	0.875	0.188 x 0.188	2.250	2.750	0.625 x 0.625	5.500	6.500	1.500 x 1.500	13.000	15.000	3.500 x 2.500
0.875	1.250	0.250 x 0.250	2.750	3.250	0.750 x 0.750	6.500	7.500	1.750 x 1.500	15.000	18.000	4.000 x 3.000
1.250	1.375	0.312 x 0.312	3.250	3.750	0.875 x 0.875	7.500	9.000	2.000 x 1.500	18.000	20.000	5.000 x 3.500
1.375	1.750	0.375 x 0.375	3.750	4.500	1.000 x 1.000	9.000	11.000	2.500 x 1.750	—	—	—

Millimeters (Per ISO R773 Standard)											
Shaft Dia	Key	Shaft Dia	Key	Shaft Dia	Key	Shaft Dia	Key	Shaft Dia	Key	Shaft Dia	Key
6	8	2 x 2	38	44	12 x 8	95	110	28 x 16	260	290	63 x 32
8	10	3 x 3	44	50	14 x 9	110	130	32 x 18	290	330	70 x 36
10	12	4 x 4	50	58	16 x 10	130	150	36 x 20	330	380	80 x 40
12	17	5 x 5	58	65	18 x 11	150	170	40 x 22	380	440	90 x 45
17	22	6 x 6	65	75	20 x 12	170	200	45 x 25	440	500	100 x 50
22	30	8 x 7	75	85	22 x 14	200	230	50 x 28	—	—	—
30	38	10 x 8	85	95	25 x 14	230	260	56 x 32	—	—	—

Table 27 — Standard Bore Fits — Unless Otherwise Specified, Falk Coupling Hubs Will Be Bored with the Following Bore Fits:

Model	Coupling Size	Coupling Type	Bore Fit
Steelex Grid Couplings	1020 - 1090	T10, T20, T31, T35, T41	Clearance
	1100 and Larger	All Types	Interference
	All Sizes	T50, T63, T70, T90	Interference

Table 28 — Recommended Bores for Steel Hubs (in)

Shaft Dia	Clearance Fit		Interference Fit		Shaft Dia	Clearance Fit		Interference Fit		Shaft Dia	Clearance Fit		Interference Fit		Shaft Dia	Interference Fit	
	Hub Bore	Clearance	Hub Bore	Interference		Hub Bore	Clearance	Hub Bore	Interference		Hub Bore	Clearance	Hub Bore	Interference		Hub Bore	Interference
+ .0000	+ .0010	.0000	+ .0005	.0000	+ .0000	+ .0015	.0000	+ .0010	.0000	+ .0000	+ .0015	.0000	+ .0015	.0010	+ .0000	+ .0015	.0015
- .0005	- .0000	.0015	- .0000	.0010	- .0010	- .0000	.0025	- .0000	.0020	- .0010	- .0000	.0025	- .0000	.0035	- .0010	- .0000	.0040
0.5000	0.5000		0.4990		2.2500	2.2500		2.2480		4.0625	4.0625		4.0590		6.7500	6.7460	
0.5625	0.5625		0.5615		3.3125	3.3125		3.3105		4.1250	4.1250		4.1215		7.0000	6.9960	
0.6250	0.6250		0.6240		2.3750	2.3750		2.3730		4.1875	4.1875		4.1840		+ .0000	+ .0020	.0020
0.6875	0.6875		0.6865		2.4375	2.4375		2.4355		4.2500	4.2500		4.2465		- .0010	- .0000	.0050
0.7500	0.7500		0.7490		2.5000	2.5000		2.4980		4.3125	4.3125		4.3090		7.2500	7.2450	
0.8125	0.8125		0.8115		2.5625	2.5625		2.5605		4.3750	4.3750		4.3715		7.5000	7.4950	
0.8750	0.8750		0.8740		2.6250	2.6250		2.6230		4.4375	4.4375		4.4340		7.7500	7.7450	
0.9375	0.9375		0.9365		2.6875	2.6875		2.6855		4.5000	4.5000		4.4965		8.0000	7.9950	
1.0000	1.0000		0.9990		2.7500	2.7500		2.7480		4.5625	4.5625		4.5590		8.2500	8.2445	.0025
1.0625	1.0625		1.0615		2.8125	2.8125		2.8105		4.6250	4.6250		4.6215		8.5000	8.4945	.0055
1.1250	1.1250		1.1240		2.8750	2.8750		2.8730		4.6875	4.6875		4.6840		8.7500	8.7445	
1.1875	1.1875		1.1865		2.9375	2.9375		2.9355		4.7500	4.7500		4.7465		9.0000	8.9945	
1.2500	1.2500		1.2490		3.0000	3.0000		2.9980		4.8125	4.8125		4.8090		9.2500	9.2440	.0030
1.3125	1.3125		1.3115		+ .0000	+ .0015	.0000	+ .0010	.0005	4.8750	4.8750		4.8715		9.5000	9.4940	.0060
1.3750	1.3750		1.3740		- .0010	- .0000	.0025	- .0000	.0025	4.9375	4.9375		4.9340		9.7500	9.7440	
1.4375	1.4375		1.4365		3.0625	3.0625		3.0600		5.0000	5.0000		4.9965		10.0000	9.9940	
1.5000	1.5000		1.4990		3.1250	3.1250		3.1225		5.0625	5.0625		5.0585	.0015	10.2500	10.2435	.0035
+ .0000	+ .0010	.0000	+ .0005	.0000	3.1875	3.1875		3.1850		5.1250	5.1250		5.1210	.0040	10.5000	10.4935	.0065
- .0010	- .0000	.0020	- .0000	.0015	3.2500	3.2500		3.2475		5.1875	5.1875		5.1835		10.7500	10.7435	
1.5625	1.5625		1.5610		3.3125	3.3125		3.3100		5.2500	5.2500		5.2460		11.0000	10.9935	
1.6250	1.6250		1.6235		3.3750	3.3750		3.3725		5.3125	5.3125		5.3085		11.2500	11.2430	.0040
1.6875	1.6875		1.6860		3.4375	3.4375		3.4350		5.3750	5.3750		5.3710		11.5000	11.4930	.0070
1.7500	1.7500		1.7485		3.5000	3.5000		3.4975		5.4375	5.4375		5.4335		11.7500	11.7430	
1.8125	1.8125		1.8110		3.5625	3.5625		3.5600		5.5000	5.5000		5.4960		12.0000	11.9930	
1.8750	1.8750		1.8735		3.6250	3.6250		3.6225		5.5625	5.5625		5.5585		12.5000	12.4925	.0045
1.9375	1.9375		1.9360		3.6875	3.6875		3.6850		5.6250	5.6250		5.6210		13.0000	12.9925	.0075
2.0000	2.0000		1.9985		3.7500	3.7500		3.7475		5.6875	5.6875		5.6835		13.5000	13.4920	.0050
+ .0000	+ .0015	.0000	+ .0005	.0000	3.8125	3.8125		3.8100		5.7500	5.7500		5.7460		14.0000	13.9920	.0080
- .0010	- .0000	.0025	- .0000	.0015	3.8750	3.8750		3.8725		5.8125	5.8125		5.8085		14.5000	14.4915	.0055
2.0625	2.0625		2.0610		3.9375	3.9375		3.9350		5.8750	5.8750		5.8710		15.0000	14.9915	.0085
2.1250	2.1250		2.1235		4.0000	4.0000		3.9975		5.9375	5.9375		5.9335		+ .000	+ .0025	.0055
2.1875	2.1875		2.1860							6.0000	6.0000		5.9960		- .001	- .0000	.0090
										6.2500	6.2500		6.2460		15.5000	15.4910	
										6.5000	6.5000		6.4960		16.0000	15.9910	
															16.5000	16.4905	.0060
															17.0000	16.9905	.0095
															17.5000	17.4895	.0070
															18.0000	17.9895	.0105
															18.5000	18.4890	.0075
															19.0000	18.9890	.0110
															19.5000	19.4880	.0085
															20.0000	19.9880	.0120

① For shaft diameters larger than 20.000", use an average interference fit of 0.0005" per inch of shaft diameter within the following bore tolerances:
 +.003, -.000 for over 20 to 30 dia. incl.
 +.004, -.000 for over 30 to 40 dia. incl.
 Tolerances and fits comply with, or are within, AGMA 9002 standard (Class 1 clearance fit).

Engineering Data

Table 29 — Recommended Bore Tolerances Falk Steel Coupling Hubs — Millimeters

Shaft Diameter (ISO/R775-1969)		Bore Diameter Tolerance		
Nominal	Tolerance	Clearance	Transitional	Interference
6 to 30	j6 / k6 ①	F7	H7	M6
Over 30 to 50	k6	F7	H7	K6
Over 50 to 80	m6	F7	H7	K7
Over 80 to 100	m6	F7	H7	M7
Over 100 to 200	m6	F7	H7	P7
Over 200 to 355	m6	F7	H7	R7
Over 355 to 500	m6	F7	H7	R8

① Per DIN 748 — Differs from ISO/R775.

Table 30 — Recommended Bores for Metric Shafts per ISO/R775-1969 (ANSI/AGMA 9112) ②

	Shaft Diameter	Clearance Fit		Transitional Fit		Interference Fit	
		Hub Bore	Fit ③	Hub Bore	Fit ③	Hub Bore	Fit ③
	j6	F7	+ .008	H7	- .008	M6	- .023
MM	+ .008 / - .003	+ .016 / + .034	+ .037	+ .000 / + .018	+ .021	- .015 / - .004	- .001
12	0.4727 / 0.4724	0.4731 / 0.4737	+ .0003	0.4725 / 0.4731	- .0003	0.4718 / 0.4723	- .0009
14	0.5515 / 0.5511	0.5518 / 0.5525	+ .0015	0.5512 / 0.5519	+ .0008	0.5506 / 0.5511	+ .0000
16	0.6302 / 0.6298	0.6306 / 0.6312	↓	0.6300 / 0.6306	↓	0.6293 / 0.6298	↓
18	0.7089 / 0.7086	0.7093 / 0.7100	↓	0.7087 / 0.7093	↓	0.7080 / 0.7085	↓
	j6	F7	+ .011	H7	- .009	M6	- .026
MM	+ .009 / - .004	+ .020 / + .041	+ .045	+ .000 / + .021	+ .025	- .017 / - .004	+ .000
19	0.7483 / 0.7479	0.7488 / 0.7496	+ .0004	0.7481 / 0.7488	- .0004	0.7473 / 0.7479	- .0010
20	0.7877 / 0.7873	0.7882 / 0.7890	+ .0018	0.7874 / 0.7882	+ .0010	0.7867 / 0.7873	+ .0000
22	0.8665 / 0.8660	0.8670 / 0.8677	↓	0.8662 / 0.8669	↓	0.8654 / 0.8660	↓
24	0.9452 / 0.9448	0.9457 / 0.9465	↓	0.9449 / 0.9457	↓	0.9442 / 0.9448	↓
25	0.9846 / 0.9841	0.9851 / 0.9858	↓	0.9843 / 0.9850	↓	0.9835 / 0.9841	↓
28	1.1027 / 1.1022	1.1032 / 1.1039	↓	1.1024 / 1.1032	↓	1.1017 / 1.1022	↓
30	1.1814 / 1.1810	1.1819 / 1.1827	↓	1.1811 / 1.1819	↓	1.1804 / 1.1810	↓
	k6	F7	+ .007	H7	- .018	K6	- .031
MM	+ .018 / + .002	+ .025 / + .050	+ .048	+ .000 / + .025	+ .023	- .013 / + .003	+ .001
32	1.2605 / 1.2600	1.2609 / 1.2618	+ .0003	1.2599 / 1.2608	- .0007	1.2593 / 1.2600	- .0012
35	1.3786 / 1.3781	1.3790 / 1.3799	+ .0019	1.3780 / 1.3789	+ .0009	1.3774 / 1.3781	+ .0000
38	1.4967 / 1.4962	1.4971 / 1.4980	↓	1.4961 / 1.4970	↓	1.4955 / 1.4962	↓
40	1.5755 / 1.5750	1.5758 / 1.5767	↓	1.5748 / 1.5758	↓	1.5743 / 1.5750	↓
42	1.6542 / 1.6537	1.6546 / 1.6555	↓	1.6536 / 1.6545	↓	1.6530 / 1.6537	↓
45	1.7723 / 1.7718	1.7727 / 1.7736	↓	1.7717 / 1.7726	↓	1.7711 / 1.7718	↓
48	1.8904 / 1.8899	1.8908 / 1.8917	↓	1.8898 / 1.8907	↓	1.8892 / 1.8899	↓
50	1.9692 / 1.9686	1.9695 / 1.9704	↓	1.9685 / 1.9695	↓	1.9680 / 1.9687	↓
	m6	F7	+ .000	H7	- .030	K7	- .051
MM	+ .030 / + .011	+ .030 / + .060	+ .049	+ .000 / + .030	+ .019	- .021 / + .009	- .002
55	2.1665 / 2.1658	2.1666 / 2.1677	+ .0000	2.1654 / 2.1665	- .0012	2.1645 / 2.1657	- .0020
56	2.2059 / 2.2052	2.2059 / 2.2071	+ .0019	2.2047 / 2.2059	+ .0007	2.2039 / 2.2051	- .0001
60	2.3634 / 2.3627	2.3634 / 2.3645	↓	2.3622 / 2.3634	↓	2.3614 / 2.3626	↓
63	2.4815 / 2.4808	2.4815 / 2.4827	↓	2.4803 / 2.4815	↓	2.4795 / 2.4807	↓
65	2.5602 / 2.5595	2.5603 / 2.5614	↓	2.5591 / 2.5602	↓	2.5582 / 2.5594	↓
70	2.7571 / 2.7564	2.7571 / 2.7582	↓	2.7559 / 2.7571	↓	2.7551 / 2.7563	↓
71	2.7964 / 2.7957	2.7965 / 2.7976	↓	2.7953 / 2.7964	↓	2.7944 / 2.7957	↓
75	2.9539 / 2.9532	2.9540 / 2.9551	↓	2.9528 / 2.9539	↓	2.9519 / 2.9531	↓
80	3.1508 / 3.1501	3.1508 / 3.1519	↓	3.1496 / 3.1508	↓	3.1488 / 3.1500	↓
	m6	F7	+ .001	H7	- .035	M7	- .070
MM	+ .035 / + .013	+ .036 / + .071	+ .058	+ .000 / + .035	+ .022	- .035 / + .000	- .013
85	3.3478 / 3.3470	3.3479 / 3.3492	+ .0000	3.3465 / 3.3478	- .0014	3.3451 / 3.3465	- .0028
90	3.5447 / 3.5438	3.5447 / 3.5461	+ .0023	3.5433 / 3.5447	+ .0009	3.5419 / 3.5433	- .0005
95	3.7415 / 3.7407	3.7416 / 3.7429	↓	3.7402 / 3.7415	↓	3.7388 / 3.7402	↓
100	3.9384 / 3.9375	3.9384 / 3.9398	↓	3.9370 / 3.9384	↓	3.9356 / 3.9370	↓
	m6	F7	+ .003	H7	- .040	P7	- .094
MM	+ .035 / + .013	+ .036 / + .071	+ .068	+ .000 / + .035	+ .025	- .059 / - .024	- .037
110	4.3321 / 4.3312	4.3321 / 4.3335	↓	4.3307 / 4.3321	↓	4.3284 / 4.3298	- .0037
120	4.7258 / 4.7249	4.7258 / 4.7272	↓	4.7244 / 4.7258	↓	4.7221 / 4.7235	- .0015
	m6	F7	+ .003	H7	- .040	P7	- .108
MM	+ .040 / + .015	+ .043 / + .083	+ .068	+ .000 / + .040	+ .025	- .068 / - .028	- .043
125	4.9228 / 4.9219	4.9230 / 4.9245	+ .0001	4.9213 / 4.9228	- .0016	4.9186 / 4.9202	- .0043
130	5.1197 / 5.1187	5.1198 / 5.1214	+ .0027	5.1181 / 5.1197	+ .0010	5.1154 / 5.1170	- .0017
140	5.5134 / 5.5124	5.5135 / 5.5151	↓	5.5118 / 5.5134	↓	5.5091 / 5.5107	↓
150	5.9071 / 5.9061	5.9072 / 5.9088	↓	5.9055 / 5.9071	↓	5.9028 / 5.9044	↓
160	6.3008 / 6.2998	6.3009 / 6.3025	↓	6.2992 / 6.3008	↓	6.2965 / 6.2981	↓
170	6.6945 / 6.6935	6.6946 / 6.6962	↓	6.6929 / 6.6945	↓	6.6902 / 6.6918	↓
180	7.0882 / 7.0872	7.0883 / 7.0899	↓	7.0866 / 7.0882	↓	7.0839 / 7.0855	↓

② Dimensions shaded are in millimeters. Non-shaded are in inches. Inch hub bore rounding practice per ISO 370-1975 (E) Method A.

③ Positive values are clearance, negative values are interference. For reference only.

Continued on page 42.

Engineering Data

Table 30 — Recommended Bores for Metric Shafts per ISO/R775–1969 (ANSI/AGMA 9112) ① (Continued)

	Shaft Diameter	Clearance Fit		Transitional Fit		Interference Fit	
		Hub Bore	Fit ②	Hub Bore	Fit ②	Hub Bore	Fit ②
>180	m6	F7	+ .004	H7	- .046	P7	- .125
MM	+ .046 / + .017	+ .050 / + .096	+ .079	+ .000 / + .046	+ .029	- .079 / - .033	- .050
190	7.4821 / 7.4810	7.4823 / 7.4841	+ .0002	7.4803 / 7.4821	- .0018	7.4772 / 7.4790	- .0049
200	7.8758 / 7.8747	7.8760 / 7.8778	+ .0031	7.8740 / 7.8758	+ .0011	7.8709 / 7.8727	- .0020
>200	m6	F7		H7		R7	- .155
MM	+ .046 / + .017	+ .050 / + .096		+ .000 / + .046		- .109 / - .063	- .080
210	8.2695 / 8.2684	8.2697 / 8.2715		8.2677 / 8.2695		8.2634 / 8.2652	- .0061
220	8.6632 / 8.6621	8.6634 / 8.6652		8.6614 / 8.6632		8.6571 / 8.6589	- .0031
225	8.8601 / 8.8589	8.8602 / 8.8620		8.8583 / 8.8601		8.8540 / 8.8558	▼
>225	m6	F7		H7		R7	- .159
MM	+ .046 / + .017	+ .050 / + .096		+ .000 / + .046		- .113 / - .067	- .084
230	9.0569 / 9.0558	9.0571 / 9.0589		9.0551 / 9.0569		9.0507 / 9.0525	- .0063
240	9.4506 / 9.4495	9.4508 / 9.4526		9.4488 / 9.4506		9.4444 / 9.4462	- .0033
250	9.8443 / 9.8432	9.8445 / 9.8463		9.8425 / 9.8443		9.8381 / 9.8399	▼
>250	m6	F7	+ .004	H7	- .052	R7	- .178
MM	+ .052 / + .020	+ .056 / + .108	+ .088	+ .000 / + .052	+ .032	- .126 / - .074	- .094
260	10.2383 / 10.2370	10.2384 / 10.2405	+ .0002	10.2362 / 10.2383	- .0020	10.2313 / 10.2333	- .0070
270	10.6320 / 10.6307	10.6321 / 10.6342	+ .0035	10.6299 / 10.6320	+ .0013	10.6250 / 10.6270	- .0037
280	11.0257 / 11.0244	11.0258 / 11.0279		11.0236 / 11.0257		11.0187 / 11.0207	▼
>280	m6	F7		H7		R7	- .182
MM	+ .052 / + .020	+ .056 / + .108		+ .000 / + .052		- .130 / - .078	- .098
290	11.4194 / 11.4181	11.4195 / 11.4216		11.4173 / 11.4194		11.4122 / 11.4143	- .0072
300	11.8131 / 11.8118	11.8132 / 11.8153		11.8110 / 11.8131		11.8059 / 11.8080	- .0039
310	12.2068 / 12.2055	12.2069 / 12.2090		12.2047 / 12.2068		12.1996 / 12.2017	▼
315	12.4036 / 12.4024	12.4038 / 12.4058		12.4016 / 12.4036		12.3965 / 12.3985	▼
>315	m6	F7	+ .005	H7	- .057	R7	- .201
MM	+ .057 / + .021	+ .062 / + .119	+ .098	+ .000 / + .057	+ .036	- .144 / - .087	- .108
320	12.6007 / 12.5993	12.6009 / 12.6031	+ .0008	12.5984 / 12.6007	- .0022	12.5928 / 12.5950	- .0079
330	12.9944 / 12.9930	12.9946 / 12.9968		12.9921 / 12.9944	+ .0014	12.9865 / 12.9887	- .0043
340	13.3881 / 13.3867	13.3883 / 13.3905		13.3858 / 13.3881		13.3802 / 13.3824	▼
350	13.7818 / 13.7804	13.7820 / 13.7842		13.7795 / 13.7818		13.7739 / 13.7761	▼
355	13.9786 / 13.9772	13.9788 / 13.9811		13.9764 / 13.9786		13.9707 / 13.9730	▼
>355	m6	F7		H7		R8	- .260
MM	+ .057 / + .021	+ .062 / + .119		+ .000 / + .057		- .203 / - .114	- .135
360	14.1755 / 14.1741	14.1757 / 14.1779		14.1732 / 14.1755		14.1652 / 14.1687	- .0102
370	14.5692 / 14.5678	14.5694 / 14.5716		14.5669 / 14.5692		14.5589 / 14.5624	- .0053
380	14.9629 / 14.9615	14.9631 / 14.9653		14.9606 / 14.9629		14.9526 / 14.9561	▼
390	15.3566 / 15.3552	15.3568 / 15.3590		15.3543 / 15.3566		15.3463 / 15.3498	▼
400	15.7503 / 15.7489	15.7505 / 15.7527		15.7480 / 15.7503		15.7400 / 15.7435	▼
>400	m6	F7	+ .005	H7	- .063	R8	- .286
MM	+ .063 / + .023	+ .068 / + .131	+ .108	+ .000 / + .063	+ .040	- .223 / - .126	- .149
410	16.1442 / 16.1426	16.1444 / 16.1469	+ .0002	16.1417 / 16.1442	- .0025	16.1330 / 16.1368	- .0113
420	16.5379 / 16.5363	16.5381 / 16.5406	+ .0043	16.5354 / 16.5379	+ .0016	16.5267 / 16.5305	- .0059
430	16.9316 / 16.9300	16.9318 / 16.9343		16.9291 / 16.9316		16.9204 / 16.9242	▼
440	17.3253 / 17.3237	17.3255 / 17.3280		17.3228 / 17.3253		17.3141 / 17.3179	▼
450	17.7190 / 17.7174	17.7192 / 17.7217		17.7165 / 17.7190		17.7078 / 17.7116	▼
>450	m6	F7		H7		R8	- .292
MM	+ .063 / + .023	+ .068 / + .131		+ .000 / + .063		- .229 / - .132	- .155
460	18.1127 / 18.1111	18.1129 / 18.1154		18.1102 / 18.1127		18.1012 / 18.1050	- .0115
470	18.5064 / 18.5048	18.5066 / 18.5091		18.5039 / 18.5064		18.4949 / 18.4987	- .0061
480	18.9001 / 18.8985	18.9003 / 18.9028		18.8976 / 18.9001		18.8886 / 18.8924	▼
490	19.2938 / 19.2922	19.2940 / 19.2965		19.2913 / 19.2938		19.2823 / 19.2861	▼
500	19.6875 / 19.6859	19.6877 / 19.6902		19.6850 / 19.6875		19.6760 / 19.6798	▼

① Dimensions shaded are in millimeters. Non-shaded are in inches. Inch hub bore rounding practice per ISO 370-1975 (E) Method A.

② Positive values are clearance, negative values are interference. For reference only.



866-REXNORD/866-739-6673 (Within the US)
414-643-2366 (Outside the US)
www.rexnord.com

Why Choose Rexnord?

When it comes to providing highly engineered products that improve productivity and efficiency for industrial applications worldwide, Rexnord is the most reliable in the industry. Commitment to customer satisfaction and superior value extend across every business function.

Delivering Lowest Total Cost of Ownership

The highest quality products are designed to help prevent equipment downtime and increase productivity and dependable operation.

Valuable Expertise

An extensive product offering is accompanied by global sales specialists, customer service and maintenance support teams, available anytime.

Solutions to Enhance Ease of Doing Business

Commitment to operational excellence ensures the right products at the right place at the right time.

Rexnord Corporation

Rexnord is a growth-oriented, multi-platform industrial company with leading market shares and highly trusted brands that serve a diverse array of global end markets.

Process and Motion Control

The Rexnord Process and Motion Control platform designs, manufactures, markets and services specified, highly engineered mechanical components used within complex systems where our customers' reliability requirements and the cost of failure or downtime are extremely high.

Water Management

The Rexnord Water Management platform designs, procures, manufactures and markets products that provide and enhance water quality, safety, flow control and conservation.

REXNORD

Rex® **FALK** **Link-Belt**® **mar/bett**® **MCC** **BERG** **highfield** **Stearns**®