

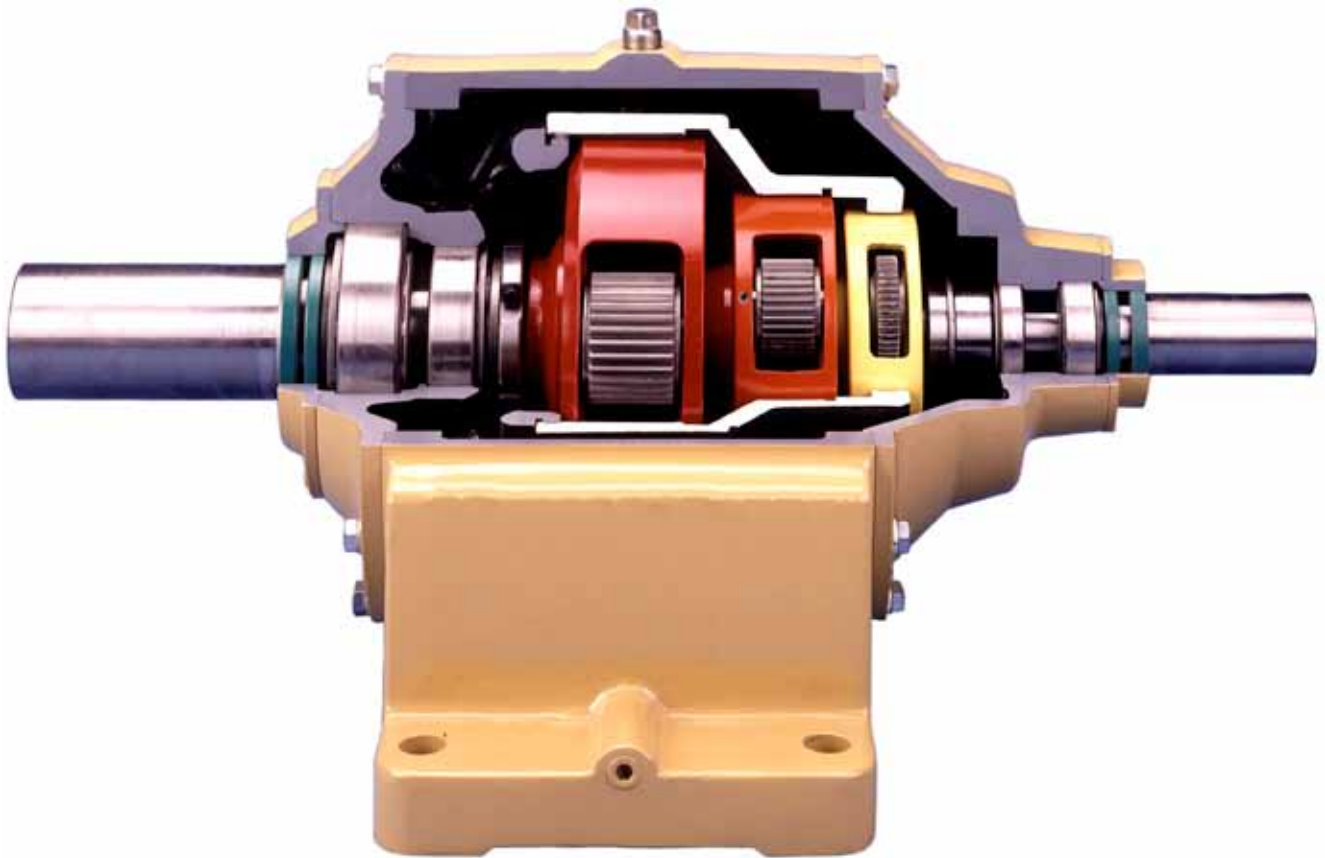

Planetgear 7000 Speed Reducers (Inch)



Planetgear 7000 Speed Reducers



To learn more about the Planetgear 7000 Speed Reducers,
go to www.rexnord.com, where you'll find:

Product information • Brochures • Catalogs • Manuals

866-REXNORD/866-739-6673 (toll-free within the U.S.) or 414-643-2366 (Outside the U.S.)

Table Of Contents

DESCRIPTION	PAGE
Section 1 – Selection Procedures.....	6
Section 2 – Quick Selection Tables.....	16
Section 3 – Dimensional Drawings.....	31
Section 4 – Technical Information.....	46
Section 5 – Installation and Maintenance Information.....	66
Section 6 – Specialty Engineered Products.....	71
Section 7 – General Engineering Information.....	75
Section 8 – Quick Reference.....	84

Accessories

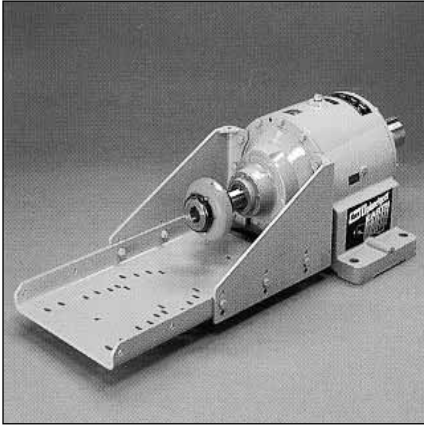

Rigid scoop facilitates mounting and alignment of most motor frame sizes and eases final installation of the drive package.



Fans and shrouds furnished to maximize lubricant life and reducer performance.

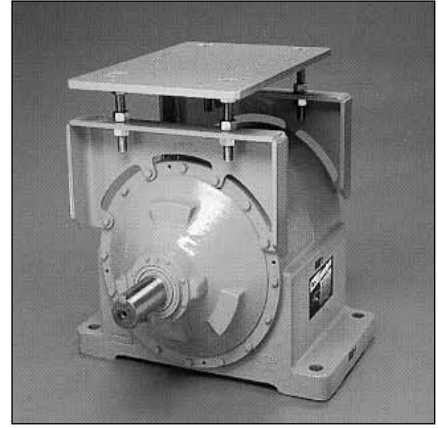

Planetgear™ motor mount saves space and allows precise speed adjustment.

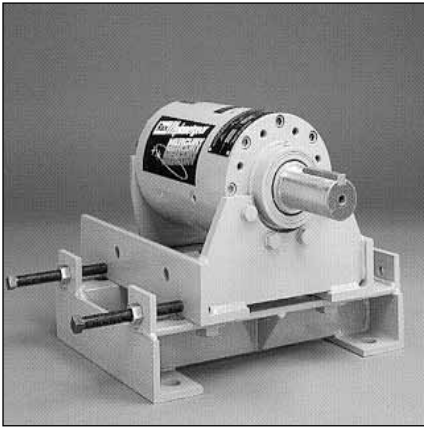

Slidebases available for all reducers to facilitate chain tensioning.

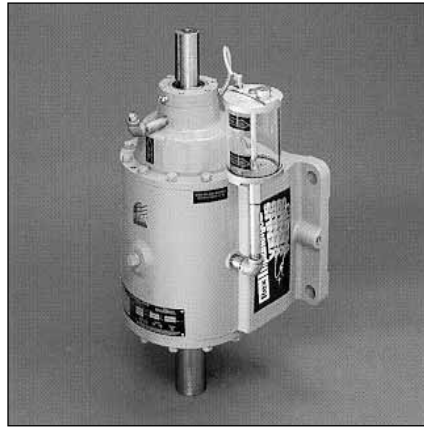

Reducers are easily modified for vertical service with either low speed or high speed shaft down.



Flanged motor mounts are available in Mercury through Polaris sizes, for NEMA frame sizes 56C to 286TC.

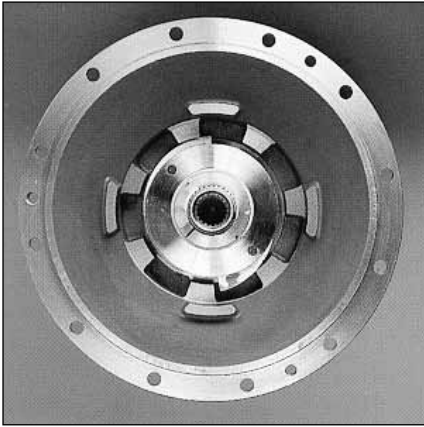

Internally mounted, oil lubricated backstops are available for all Planetgear 7000 reducers. Backstops are not limited by load, duration, or frequency of operation. They can operate in extreme pressure oil, and can be installed in the field without removal of gearing.

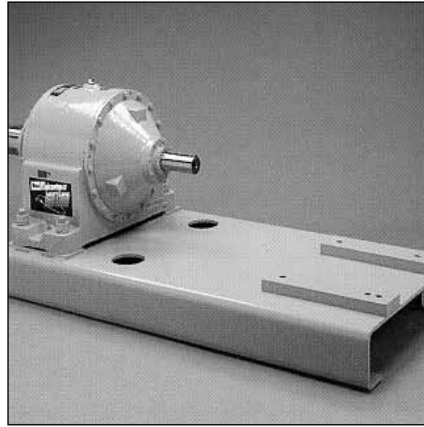

Large motors are easily accommodated on sturdy baseplates. Planetgear will furnish motors or mount those furnished by others.



Custom adapters are available to facilitate mounting configurations.

Proven, Reliable Gear Performance

With Planetgear 7000 reducers, self-aligning planet carriers float radially and axially to provide perfect alignment of the gear train. Unlike “traditional gears” which have only one point of contact per reduction, Planetgear 7000 transmits the torque through three points of contact between sun gears and planet gears. The floating gear train ensures equal loading among the three points. State of the art heat-treating techniques provide hardened, wear-resistant gearing.

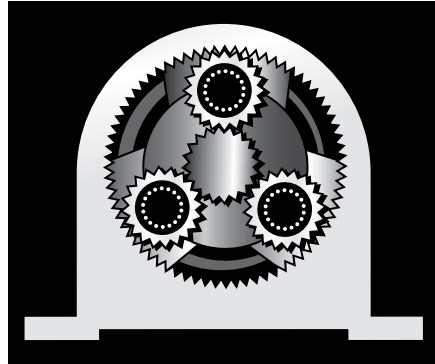

← Three points of contact

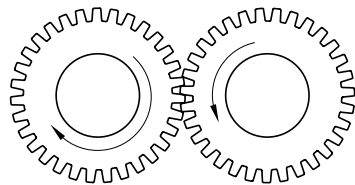

Traditional Gears — only one point of contact

Superior Seal Protection

How many reducer failures are attributed to bearing contamination?

Planetgear 7000 reducers are designed with **TWO** seals on both the input and output shafts. Our successful seal layout can be seen in the schematic shown below.

Double-lipped inboard seal:
Keeps the oil in and grease out.

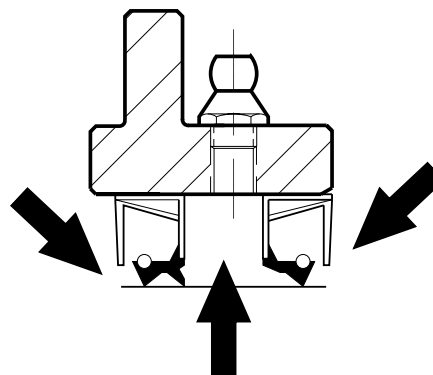

Single-lipped outboard seal:
Keeps the contaminants out.

Grease Purgeable Cavity

Planetgear 7000 reducers assure you extended reducer service-life even in the worst environments.

General Selection Information

INTRODUCTION

Before a reducer can be selected for any application, the equivalent output torque or horsepower must be computed by multiplying the actual or specified torque or horsepower by the service factor (S.F.) for the particular load classification for which the unit is to be used. It is necessary that the unit selected have a capacity equal to or in excess of the equivalent output torque (lb-in) or horsepower.

Reducers can be selected by Service Factor or Load Classification. Both Service Factors and Load Classifications are a means of classifying different equipment and applications into a uniform guideline useful for reducer selection. Due to variations in application, service factors are used to adjust equipment ratings to accommodate differing load conditions. Applications involving unusual or severe loading should be carefully reviewed before a service factor is applied (consult factory). Care must be taken by the customer to isolate the reducer from unplanned transient loads or vibrating conditions.

For unusual application requirements such as those listed below, consult the factory for application assistance.

- Temperatures less than 15°F (-9°C) on more than 125°F (52°C).
- Corrosive, chemical or explosive fumes.
- Tilted, rotated ceiling, wall or submerged mounting requirements.
- Unusual atmosphere such as vacuum, high pressure or high altitude.

Momentary Overloads

The maximum momentary or starting load applied to a reducer must not exceed 250% of rated load. Rated load is defined as the reducer rating at a service factor of 1.0. Applications with high torque motors and motors for intermittent operations should be referred to the factory. Also, applications where extreme repetitive shock occurs or when high-energy loads must be absorbed, as when stalling, require special considerations and should be referred to the factory.

Brake Loads

When drives are equipped with brakes on the input, and the torque rating of the brake exceeds the rating of the motor, the rating of the brake dictates the selection of the reducer.

Operating Temperature

It is important the maximum oil temperature not exceed 200°F (93°C). If a continuous ambient temperature of 115°F (46°C) or higher exists, please contact the factory. Thermal limitations may exist for some units with low ratios. Heat exchangers are available for these applications that exceed the thermal capacity of reducers with fans and shrouds.

Thermal Capacity

Heat exchangers are available for those applications that are thermally limited, contact factory.

Moment of Inertia

The moment of inertia values are listed in **Table 35, page 65**.

Lubrication

Planetgear 7000 reducers are shipped without oil and must be filled to the specified oil level before start-up. Lubrication instructions can be found on the reducer nameplate, including required frequency of oil changes. Additional information on lubrication and oil capacities are listed in the Owners Manual.

Multi-Speed Selections

Reducers that will be operated at a variety of input speeds must be selected for the speed that yields the highest output torque requirement.

Backstops

Reverse rotation is prevented through the use of Planetgear backstops on all reducer series. The ratchet mechanism engages at any frequency for any time span, thus providing indexing, or positioning capabilities. The pawls disengage by centrifugal force assuring quiet operation.

Our internally mounted backstops operate in conventional gear oil.

Available as stocked accessories, they are easily installed or reversed in the field without removal of gearing. Conversion of our standard Mercury and Mars models requires a complete backstop input endbell assembly.

When ordering a Planetgear 7000 reducer with a backstop, indicate the reducer rotation as clockwise or counterclockwise when looking towards the reducer from the low speed end. Note: consult factory if using a backstop in an application that has an input speed of 400 RPM or less.

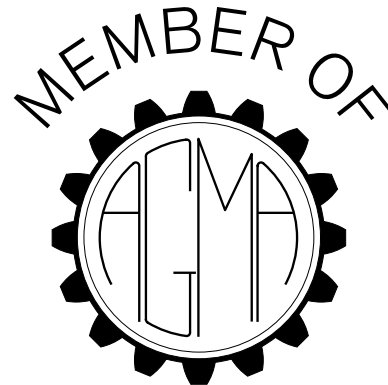

Motorized Selection (Scoop Mount and C-face)

Three classes designated by Roman Numerals I, II and III were established by NEMA to relate the package or “Drive” to a large variety of applications. These applications were classified by load factors and hours per day of use. A service classification table using this nomenclature for typical applications is located on **pages 8 & 9**. Reducer selections can be made based on applying these service classifications to specific motor ratings and speeds.

Planetgear 7000 scoop mounted motor reducers are available for all reducer series with capacities ranging from 1 horsepower (143T) to 250 horsepower (447T). These may be a face mounted or common base type configuration depending upon the motor size. Planetgear can furnish motors or mount those furnished by others.

Rexnord Omega couplings are standard on the high speed shaft of scoop mounted reducers. Selections for the Omega coupling can be found in **Table 20 on page 55**. A wide choice of accessories including backstops, slidebases and coupling guards are also available.

Planetgear C-face mounted motor reducers are available for Mercury through Polaris, and Neptune, Neptune Plus and Orion Plus quadruple and quintuple series. Horsepower capacities range from 1/2 horsepower (56C) to 30 horsepower (286TC). Planetgear can furnish motors or mount those furnished by others. Reference **Figure 1, page 70** for sectional view of C-face input.

PLANETGEAR SELECTION PROCEDURE - REDUCER WITH SCOOP OR C-FACE MOUNT

Step 1 — Determine the service class

- **Table 1, pages 8 & 9** lists service classes by industry, type of service and hours per day of operation.

Step 2 — Selecting the unit size

Table 11, page 30 - Table 8, page 27 list scoop mount selections for service class I, II and III for 1750 RPM motors. **Table 9, page 28 - Table 11, page 30** list C-face mount selections for service class I, II and III for 1750 RPM motors.

Read the series name under the desired motor horsepower and opposite the approximate output speed required. The number following the reducer name in the selection table is the output capacity in (x1000) pound-inches of torque.

If ambient temperature exceeds 84°F (29°C), see Step 6 of Non-motorized selection procedure to determine reducer thermal rating.

Step 3 — Check for Overhung Load

Follow the overhung load procedure on **page 14** to confirm the selection when radial loads exist on the output shaft. For units that have a thrust load applied, contact factory with radial and thrust load information.

Step 4 — Check the Dimensions

Refer to the dimensional drawings on **page 37 to 42** for feet mounted motors, and **page 43 to 45** for C-face reducers. Confirm the special requirements of the selected reducer.

Step 5 — Viva & Omega Coupling Selection (scoop mount reducers only)

Refer to **Table 20 on page 53** for selection information based on reducer series and load classification.

Scoop mount reducers include face scoops and baseplates.

Step 6 — Order the Planetgear Reducer

Refer to **page 15** for information required when ordering reducers.

SELECTION EXAMPLE — REDUCER WITH SCOOP MOUNT

REQUIRED:

A drive for a uniformly fed chain conveyor operating 16 hours per day is powered by a 10 hp, 1750 rpm (215T frame) motor. Desired reducer output speed is 41 rpm. A roller chain drive having a 160B17 roller chain sprocket (10.844 inches Pitch Diameter) is mounted so that the centerline of the load is 2-1/2 inches from the reducer seal cage.

SOLUTION:

Step 1 — Determine service class

Since 16 hours per day is greater than 10 hours per day, Class II is chosen from **Table 1, pages 8 & 9**.

Step 2 — Determine the unit size

From Class II selection, reference **Table 5 on pages 20 & 21** for 1750 rpm. Locate the desired input motor horsepower column (10 hp) and read the reducer name opposite the approximate output speed that is closest to the desired value. Select Venus series with 40 rpm approximate output speed and 43.78 nominal ratio.

Step 3 — Check for overhung and thrust loads

(See calculation instructions **page 14**)

$$\text{OHL} = \frac{(126,000)(10)(1.0)(0.96)}{(10.844)40} = 2,788 \text{ lbs.}$$

The overhung load capacity from **Table 24 on page 55** for Venus reducer having 43.78 nominal ratio is 9,630 pounds. The rated capacity is greater than the actual value, therefore the selection is approved.

Step 4 — Check Dimensions

The dimensional drawing on **page 41** shows the Venus reducer with Scoop Mount and Slidebase.

- Series name = Venus
- Class of service = Class II
- Input motor hp = 10 hp
- Motor frame size = 215T
- Input motor speed = 1750 rpm
- Nominal ratio = 43.78
- Desired accessory = Slidebase, Scoop Mount, Coupling and Guard

Service Class Selections

TABLE 1

SERVICE CLASSES

APPLICATION	SERVICE		APPLICATION	SERVICE		APPLICATION	SERVICE	
	10 HRS/ DAY	24 HRS/ DAY		10 HRS/ DAY	24 HRS/ DAY		10 HRS/ DAY	24 HRS/ DAY
AGITATORS			Clay Working Machinery	II	II	FANS		
Pure Liquids	I	II	Pug Mills	II	II	Centrifugal	I	II
Liquids & Solids	II	II	COLLECTORS (Sewage)	I	II	Cooling Towers	④	④
Liquids - Variable Density	II	II	COMPRESSORS			Forced Draft	-	II
APRON CONVEYORS			Centrifugal	I	II	Induced Draft	II	II
Uniformly Loaded or Fed	I	II	Lobe	II	II	Large (Mine, etc.)	II	II
Heavy Duty	II	II	Reciprocating			Large (Industrial)	II	II
APRON FEEDERS	II	II	Multi-Cylinder	II	II	Light (Small Diameter)	I	II
ASSEMBLY CONVEYORS			Single Cylinder	III	III	FEEDERS		
Uniformly Loaded or Fed	I	II	CONCRETE MIXERS			Apron, Belt	II	II
Heavy Duty	II	II	Continuous	II	II	Disc	II	II
BALL MILLS	⑤	⑤	Intermittent	II	III	Reciprocating	III	III
BARGE HAUL PULLERS	III	III	CONVEYORS - Uniformly			Screw	II	II
BARKING			Loaded or Fed: Apron,			FLIGHT		
Drums (coupling connected)	-	III	Assembly, Belt, Bucket, Chain			Conveyors, Uniform	I	II
Mechanical	-	III	Flight, Oven, Screw	I	II	Conveyors, Heavy	II	II
BAR SCREENS (Sewage)	I	II	CONVEYOR - Heavy Duty			FOOD INDUSTRY		
BATCHERS (Textile)	II	II	Not Uniformly Fed: Apron,			Beet Slicers	II	II
BELT CONVEYORS			Assembly, Belt, Bucket, Chain			Bottling, Can Filling Mach.	I	II
Uniformly Loaded or Fed	I	II	Flight, Oven, Screw	II	II	Cereal Cookers	I	II
Heavy Duty	II	II	CONVEYOR - Severe Duty			Dough Mixers, Meat Grinders	II	II
BELT FEEDERS	II	II	Live Roll	④	④	GENERATORS (Not Welding)	I	II
BENDING ROLLS (Machine)	II	II	Reciprocating, Shaker	III	III	GRAVITY DISCHARGE		
BLOWERS			COOKERS (Brewing & Distilling)			ELEVATORS	I	II
Centrifugal	I	II	(Food)	I	II	HAMMER MILLS	III	III
Lobe	II	II	COOLING TOWER FANS	④	④	HOISTS		
Vane	I	II	CRANES			Heavy Duty	III	III
BOTTLING MACHINERY	I	II	Dry Dock Cranes	①	①	Medium Duty	II	III
BREWING & DISTILLING			Main Hoist	④	④	Skip Hoist	II	III
Bottling Machinery	I	II	Bridge and Trolley Travel	④	④	INDUCED DRAFT FANS	II	II
Brew Kettles, Cont. Duty	④	II	CRUSHERS			KILNS	⑤	⑤
Can Filling Machines	④	II	Ore or Stone	III	III	LAUNDRY WASHERS & TUMBLERS	II	II
Cookers, Cont. Duty	④	II	Sugar	-	II	LINE SHAFTS		
Mash Tubs, Cont. Duty	④	II	DEWATERING SCREENS			Driving Processing Equip.	II	III
Scale Hoppers, Freq. Starts	II	II	(Sewage)	II	II	Other Line Shafts, Light	I	II
BRICK PRESS (Clay Working)	III	III	DISC FEEDERS	I	II	LIVE ROLL CONVEYORS	④	④
BRIQUETTE MACHINES			DISTILLING (See Brewing)			LOBE BLOWERS OR COMPRESSORS	II	II
(Clay Working)	III	III	DOUBLE ACTING PUMPS			LOG HAULS (Lumber)		
BUCKET			2 or More Cylinders	II	II	Incline-well Type	III	III
Conveyors Uniform	I	II	Single Cylinder	④	④	LOOMS (Textile)	II	II
Conveyors Heavy Duty	II	II	DOUGH MIXER (Food)	II	II	LUMBER INDUSTRY		
Elevators Cont.	I	II	DRAW BENCH (Metal Mills)			Barkers - Spindle Feed	II	III
Elevators Uniform	I	II	Carriage & Main Drive	II	III	Barkers - Main Drive	III	III
Elevators Heavy Duty	II	II	DREDGES			Carriage Drive	④	④
CALENDERS			Cable Reels, Conveyors	II	III	Chain - Floor	II	III
Rubber	II	II	Cutter Head & Jig Drives	III	III	Chains - Green	II	III
Textile	II	II	Maneuvering Winches, Pumps	II	II	Conveyors		
CAN FILLING MACHINES			Screen Drives	III	III	Burner	II	III
CANE KNIVES	I	II	Stackers, Utility Winches	II	II	Main or Heavy Duty	II	III
CARD MACHINES (Textile)	II	II	DRY DOCK CRANES	①	①	Main Log	III	III
CAR DUMPERS	III	III	DRYERS & COOLERS			Re-Saw Merry-Go-Round	II	III
CAR PULLERS	II	III	(Mills, Rotary)	-	III	Slab	III	III
CEMENT KILNS	⑤	⑤	DYEING MACHINERY			Transfer	II	III
CENTRIFUGAL			(Textile)	II	II	Cut-Off Saws-Chain & Drag	II	III
Blowers, Compressors,			ELEVATORS			Debarking Drums	III	III
Discharge Elevators,			Bucket - Uniform Load	I	II	Feeds - Edger	II	III
Fans or Pumps	I	II	Bucket - Heavy Duty	II	II	Feeds - Gang	III	III
CHAIN CONVEYORS			Bucket - Continuous	I	II	Feeds - Trimmer	II	III
Uniformly Loaded or Fed	I	II	Centrifugal Discharge	I	II	Log Deck	III	III
Heavy Duty	II	II	Escalators	④	④	Log Hauls- Incline-Well type	III	III
CHEMICAL FEEDERS			Freight	④	④	Log Turning Devices	III	III
(Sewage)	I	II	Gravity Discharge	I	II	Planer Feed	II	III
CLARIFIERS	I	II	Man Lifts, Passenger	④	④	Planer Tilting Hoists	II	III
CLASSIFIERS	II	II	EXTRUDERS ⑦	⑦	⑦	Rolls, Live Off Bearing		
CLAY WORKING INDUSTRY						Roll Cases	III	III
Brick Press	III	III				Sorting, Table, Tipple Hoist	II	III
Briquette Machines	III	III				Transfers - Chain & Craneway	II	III

① DRY DOCK CRANES (Hammerhead, Rotating and Whirler, Stationary or Moving) for any duration of service: Main Hoist, Auxiliary Hoist, Boom (Lifting): 3.00 S.F.; Rotating (Swing or Slew): 3.00 S.F.; Tracking (Drive Wheels): 3.00 S.F.

② Service factors for paper mill application are applied to nameplate rating of electric motor at the motor rated base speed - consistent with TAPPI Standards.

③ When a super calender operates over a speed range of part constant hp and torque and the constant hp speed range is greater than 1.5:1, use a service factor of 1.0 at base speed. When operating at constant torque over the entire speed range or when the constant hp speed range is less than 1.5:1 a 1.25 factor should be applied.

④ Consult factory.

⑤ See Mills, Rotary.

⑥ Using anti-friction bearings only.

⑦ See Rubber & Plastics Industries.

Service Class Selections

TABLE 1 CONTINUED

SERVICE CLASSES

APPLICATION	SERVICE		APPLICATION	SERVICE		APPLICATION	SERVICE	
	10 HRS/ DAY	24 HRS/ DAY		10 HRS/ DAY	24 HRS/ DAY		10 HRS/ DAY	24 HRS/ DAY
Tray Devices	II	III	Couch Rolls	-	II	Mills (3 on line)	II	II
Veneer Lathe Drives	④	④	Cutter	-	III	Mixing Mills	III	III
MACHINE TOOLS			Cylinder Molds	-	II	Refiners & Sheeters	II	II
Auxiliary Drives	I	II	Dryers ⑥ –			SAND MULLERS	II	II
Bending Rolls	II	II	Paper Machine & Conveyor Type	-	II	SCREENS		
Main Drives	II	II	Embossers	-	II	Air Washing	I	II
Notching Press (Belted)	④	④	Extruder	-	III	Rotary – Stone or Gravel	II	II
Plate Planers	III	III	Foundrinier Rolls–			Traveling Water Intake	I	II
Punch Press (Geared)	III	III	Lumberbreaker, Wire Turning, Dandy			SCREW CONVEYORS		
Tapping Machines	III	III	& Return Rolls	-	II	Uniform	I	II
MANGLE (Textile)	II	II	Jordan	-	II	Heavy Duty or Feeder	II	II
MAST TUBS (Brewing & Distilling)	I	II	Kiln Drive	-	III	SCUM BREAKERS (Sewage)	II	II
MEAT GRINDERS (Food)	II	II	Mt. Hope & Paper Rolls	-	II	SEWAGE DISPOSAL		
METAL MILLS			Platter	-	II	Bar Screens	I	II
Draw Bench Carriages & Main Drives	II	III	Presses (Felt & Suction)	-	II	Chemical Feeders	I	II
Pinch, Dryer & Scrubber			Pulper – continuous	-	II	Collectors	I	II
Rolls Reversing	④	④	Repulper – heavy stock	-	III	Dewatering Screens	II	II
Slitters	II	II	Vacuum Pumps	-	II	Scum Breakers	II	II
Table Conveyors			Reel (Surface Type)	-	II	Slow or Rapid Mixers	II	II
Non-Reversing			Screens –			Thickeners	II	II
Group Drives	II	III	Chip, Rotary	-	II	Vacuum Filters	II	II
Individual	III	III	Vibrating	-	III	SHAKER CONVEYORS	III	III
Reversing	④	④	Size Press	-	II	SINGLE ACTING PUMPS		
Wire Drawing & Flattening Machines	II	III	Super Calender ③	-	II	1 or 2 Cylinders	④	④
Wire Winding Machines	II	II	Thickener & Washer –			3 or more Cylinders	II	II
MILLS, ROTARY			AC Motor	-	II	SKIP HOIST	II	III
Ball and Rod Mills			DC Motor	-	II	SLAB PUSHERS	II	II
with Spur Ring Gear	-	III	Wind & Unwind Stand	-	I	SLITTERS (Metal Mills)	II	II
with Helical Ring Gear	-	III	Winders (Surface Type)	-	II	SLUDGE COLLECTORS		
Direct Connected	-	III	Yankee Dryers ⑥	-	II	(Sewage)	I	II
Kilns, Dryers, Coolers			PASSENGERS ELEVATORS	④	④	SOAPERS (Textile)	II	II
Pebble, Plain & Cement Kilns	④	④	PEBBLE MILLS	-	III	SPINNERS (Textile)	II	II
Wedge Bar	-	III	PLASTIC INDUSTRY ⑦	⑦	⑦	STEERING GEARS	④	④
Tumbling Barrels	III	III	PLATE PLANNERS	III	III	STOKERS	I	II
MIXERS (Also see Agitators)			PRINTING PRESSES	④	④	STONE CRUSHERS	III	III
Concrete, Cont.	II	II	PROPORTIONING PUMPS	II	II	SUGAR INDUSTRY		
Concrete, Int.	II	III	PUG MILLS (Clay)	II	II	Cane, Knives, Crushers	II	II
Constant Density	I	II	PULLERS (Barge Haul)	III	III	Mills (low speed end)	III	III
Variable Density	II	II	PUMPS			TABLE CONVEYORS		
NAPPERS (Textile)	II	II	Centrifugal	I	II	(Non-Reversing)		
OIL INDUSTRY			Proportioning	II	II	Group Drives	II	III
Chillers	II	II	Reciprocating – Single Action			Individual Drives	III	III
Oil Well Pumping	④	④	3 or More Cylinders	II	II	Reversing	④	④
Paraffin Filter Press	II	II	Reciprocating – Dbl Action			TENTER FRAMES (Textile)	II	II
Rotary Kilns	II	II	2 or More Cylinders	II	II	TEXTILE INDUSTRY		
ORE CRUSHERS	III	III	Reciprocating – Single Action			Batchers, Calendars	II	II
OVEN CONVEYORS			1 or 2 Cylinders	④	④	Card Machines	II	II
Uniform	I	II	Reciprocating – Dbl Action			Dry Cans, Dryers	II	II
Heavy Duty	II	II	Rotary Gear, Lobe, Vane	I	II	Dyeing Machinery	II	II
PAPER MILLS ②			PUNCH PRESSES			Knitting Machinery	④	④
Agitator (Mixer)	-	II	(Gear Driven)	III	III	Looms, Manglers, Nappers, Pads	II	II
Agitator for Pure Liquors	-	II	RECIPROCATING			Range Drives	④	④
Barking Drums, Barkers – Mechanical	-	III	Conveyors, Feeders	III	III	Slashers, Soapers, Spinners	II	II
Beater	-	II	RECIPROCATING			Tenter Frames, Washers, Winders	II	II
Breaker Stack	-	II	COMPRESSORS			THICKENERS (Sewage)	II	II
Calender ⑥	-	II	Multi-Cylinder	II	II	TUMBLING BARRELS	III	III
Chipper	-	III	Single-Cylinder	III	III	VACUUM FILTERS (Sewage)	II	II
Chip Feeder	-	II	ROD MILLS	⑤	⑤	VANE BLOWERS	I	II
Coating Rolls	-	II	ROTARY			WINCHES (Dredges)	II	III
Conveyors –			Pumps	I	II	WINDERS (Textile)	II	II
Chip, Bark, Chemical	-	II	Screens (Stone or Gravel)	II	II	WINDLASS	④	④
Log (Including Slab)	-	III	RUBBER & PLASTICS INDUSTRIES			WIRE		
			Calenders	II	II	Drawing Machines	II	III
			Crackers	III	III	Winding Machines	II	II
			Mills (2 on line)	II	II			

① DRY DOCK CRANES (Hammerhead, Rotating and Whirler, Stationary or Moving) for any duration of service: Main Hoist, Auxiliary Hoist, Boom (Lifting): 3.00 S.F.; Rotating (Swing or Slew): 3.00 S.F.; Tracking (Drive Wheels): 3.00 S.F.

② Service factors for paper mill application are applied to nameplate rating of electric motor at the motor rated base speed - consistent with TAPPI Standards.

③ When a super calender operates over a speed range of part constant hp and torque and the constant hp speed range is greater than 1.5:1, use a service factor of 1.0 at base speed. When operating at constant torque over the entire speed range or when the constant hp speed range is less than 1.5:1 a 1.25 factor should be applied.

④ Consult factory.

⑤ See Mills, Rotary.

⑥ Using anti-friction bearings only.

⑦ See Rubber & Plastics Industries.

Non-Motorized Selection

(For motorized reducer selections, see page 7)

INTRODUCTION

Selection and pricing of Planetgear 7000 is based solely on the required output torque capacity of the application. The service factor method is used to apply specific industry application standards based on the hours per day of operation. These application standards are cataloged and have been developed based on practical application experience.

The following information demonstrates how this procedure allows the selection of the most economical Planetgear reducer.

Information Required To Make Reducer Selection

- The specific application and hours per day of operation.
- Reducer input speed.
- Input Horsepower.
- Desired reducer output speed.
- If applicable, overhung load.

Step 1 — Determine Service Factor

Select the appropriate service factor **Table 2** on **pages 12 & 13** for the industry and specific applications at hand. These service factors are designed for applications driven by electric motors.

If a single or multiple cylinder engine is used, adjust the service factor that is taken from **Table 2** with the corresponding values listed below.

Steam & Gas Turbines Hydraulic or Electric Motors	Single Cylinder Engines	Multi-Cylinder Engines
1.00	1.50	1.25
1.25	1.75	1.50
1.50	2.00	1.75
1.75	2.25	2.00
2.00	2.50	2.25

Pre-selection tables are available for horizontal mounting and input speeds of 1750 rpm and service factors of 1.0, 1.25, 1.4, 1.5, 1.75 and 2.0. Use tables for selection purposes when possible. For speeds other than those listed, continue with the selection procedures as follows:

Step 2 — Calculate the desired reducer ratio (D.R.) using:

$$D.R. = \frac{\text{Input Speed (RPM)}}{\text{Output Speed (RPM)}}$$

Step 3 — Select closest nominal ratio (N.R.)

Table 32 on **page 63** lists the nominal ratios offered by Planetgear. Pick the ratio that is closest to the desired ratio calculated in Step 2.

Step 4 — Calculate equivalent output torque (E.O.T.) using:

A. When input motor horsepower is known:

$$E.O.T. = \frac{HP \times N.R. \times S.F. \times 59,900}{RPM_{in}}$$

NOTE: 59,900 is used to represent the average mechanical efficiency of reducers (59,900 = 63,025 x 95%).

B. Where required output torque is known:

$$E.O.T. = T_o \times S.F.$$

where:

- HP = Motor horsepower
- N.R. = Nominal ratio from Step 3
- S.F. = Service factor from Step 2
- RPM_{in} = Reducer input shaft speed in revolutions per minute
- T_o = Output torque required in lb-in

Step 5 — Select reducer

Reference **Table 12 to Table 19**, "Technical Information Selection", **pages 46 to 53** and locate the nominal ratio determined from Step 3. Locate the smallest series (Mercury, Mars, Venus, Atlas, Luna, Earth, Polaris, Delta, Neptune, Neptune Plus, Orion Plus, Saturn Plus, Titan Plus or Jupiter Plus), that offers the output torque (lb-in) rating that is equal to or greater than the equivalent output torque (E.O.T.) determined from Step 4 for the nominal ratio required.

Step 6 — Check thermal capacity

Checking the thermal rating is extremely important. If the drive creates heat faster than it can be dissipated, it will overheat, and severe damage may occur.

The thermal rating of a drive is the actual power in horsepower (without Service Factor) that a drive can transmit continually for three hours or more without overheating.

Thermal ratings must be considered when the continuous operating period exceeds 3 hours, or if operation is less than 3 hours and the running time is greater than the shutdown time.

Application Adjusted Thermal Rating

The application adjusted thermal rating must be greater than the actual power transmitted through the gear drive (frequently the power rating of the driving motor is used rather than the actual power transmitted). To determine the application adjusted thermal rating, look up the basic thermal rating for the drive size and ratio selected, **Table 25 to Table 32, pages 56 to 63**. Determine the application adjusted thermal rating by using the appropriate correction factors. Compare the actual power rating required (without Service Factor) with the application adjusted thermal rating. If the actual power rating exceeds the application adjusted thermal rating, shaft fans or electric fans may be added, an optional heat exchanger package may be added, or a larger drive may be selected. Review all the footnotes for the basic thermal rating to be certain which cooling accessories are available for the selected drive.

Application adjusted thermal rating is determined by using the following:

- P_{TA} = B₁ × B₂ × B₃ × B₅ × P_r where:
- P_{TA} = Application adjusted thermal rating
- P_r = Basic thermal rating from the tables in this selection guide
- B₁ = Ambient temperature factor
- B₂ = Altitude factor
- B₃ = Ambient air velocity factor (used only if auxiliary cooling is used)
- B₅ = Duty cycle factor

Ambient Temperature Factor - B ₁ (For all cooling methods)		Altitude Factor - B ₂ (For air cooling only)	
Ambient Temperature ①	Factor with or without Shaft or Electric Fan	Altitude - ft Sea level = 0	Factor with or without Auxiliary Cooling
50°F	1.19	0 to 2,500	1.00
60°F	1.13	2,500	.95
70°F	1.07	5,000	.90
80°F	1.00	7,500	.85
90°F	.93	10,000	.81
100°F	.85	12,500	.76
110°F	.78	15,000	.72
120°F	.69	17,500	.68

① Factors for other ambient temperatures can be interpolated.

Ambient Air Velocity Factor - B ₃ (For no auxiliary cooling only)		
Sustained Ambient Air Velocity - fpm	Installed Environment	Factor without Shaft or Electric Fan
Less than 100 fpm (1 mph)	Small Confined Space	.75
Between 100 fpm & 275 fpm (1 to 3 mph)	Large Indoor Room	1.00
Between 275 fpm & 725 fpm (3 to 8 mph)	Large Indoor Room	1.40
Greater than 725 fpm (8 mph)	Outdoors	1.90

Duty Cycle Factor ② - B₅ (For all cooling methods)

% Operating Time Per Hour	Factor
100%	1.00
80%	1.05
60%	1.15
40%	1.35
20%	1.80

② The duty cycle factor must be based on the percentage of each hour that the drive is operating. For example: a gear drive operating for 48 minutes and resting for 12 minutes every hour of the day has an 80% duty cycle, but a drive operating for four hours and resting for four hours has a 100% duty cycle. Where % run time per hour falls between values shown above, use next higher % run time.

Step 7 — Check overhung load

When overhung load exists on either input or output shafts, follow the appropriate explanation on **page 14** to confirm the reducer selection. For units that have a thrust load applied, contact factory with radial and thrust load information.

Step 8 — Check dimensions

Dimensional drawings for reducers with and without accessories are found on **pages 31 to 45**.

Step 9 — Ordering reducers

See reducer order form **page 15**.

SELECTION EXAMPLES — REDUCER ONLY (NON-MOTORIZED)**WHEN MOTOR HORSEPOWER IS KNOWN:**

A 100 hp, 1,750 rpm motor is used to drive a heavy duty horizontal apron conveyor 24 hrs/day. The conveyor requires a reducer output speed of 50 rpm. A roller chain drive having a 240B25 tooth roller chain sprocket (23.936 inch pitch diameter) is mounted with the center of the chain pull 4.5 inches from the seal cage. Ambient temperature is 80°F (27°C).

Step 1 — Select service factor

From **Table 2** on **pages 12 & 13**, the service factor for an apron conveyor 24 hrs/day operation is 1.5.

Step 2 — Calculate desired ratio (D.R.)

$$D.R. = \frac{1,750 \text{ RPM}}{50 \text{ RPM}} = 35$$

Step 3 — Select closest nominal ratio (N.R.)

Select **Table 34** on **page 64** = 36.56

$$\text{Output Speed} = \frac{1,750 \text{ RPM}}{36.56} = 47.9 \text{ RPM}$$

Step 4 — Calculate equivalent output torque (E.O.T.) hp method

$$E.O.T. = \frac{100 \text{ hp} \times 36.56 \text{ N.R.} \times 1.5 \text{ S.F.} \times 59,900}{1,750 \text{ (input RPM)}} = 187,709 \text{ lb-in}$$

Step 5 — Select reducer

Enter **Table 12 to Table 19**, Reducer Only Selection, located on **pages 46 to 53**. Nominal ratio is 36.56. The smallest series listed for the E.O.T. calculated in Step 4 (187,709 lb-in) is an Orion Plus.

Step 6 — Check thermal capacity

Compare the motor horsepower to the thermal ratings of the reducers with the following formula:

$$\text{Motor HP} \leq (\text{Tr})_{A_C}$$

Since the thermal rating in **Table 25**, **page 56** without fan is less than the motor horsepower, $\text{Tr} = 124$ with a cooling fan. See instructions from **page 10** for thermal adjustments.

$$100 \text{ (Motor HP)} \leq 124 \text{ (hp rating)}(1.0)$$

$$100 < 124$$

Since the motor horsepower is less than the thermal rating, the thermal capacities of the reducer with cooling fan exceeds the motor capacity.

Step 7 — Check for overhung and thrust loads

The overhung load (O.H.L.) exists on the output shaft. The input shaft is direct connected and does not encounter overhung load. Therefore (from **page 14**):

$$O.H.L. = \frac{126,000 \times 100 \text{ hp} \times 1.0 \text{ Fc} \times 0.96 \text{ Lf}}{23.936" \text{ P.D.} \times 47.9 \text{ (output RPM)}} = 10,550 \text{ lbs.}$$

The overhung load capacity from **Table 24**, **page 55** for an Orion Plus series having an output speed approximately 48 rpm is 27,100 lbs. The rated capacity is greater than the actual value, so the selection is approved.

This application does not encounter thrust load.

Step 8 — Check dimensions

Dimensions for the Orion Plus series are on **page 32**.

Step 9 — Order Planetgear reducer by:

- Series Name - Orion Plus
- Nominal Ratio - 36.56
- Output torque rating - 274,000 lb-in
- Input motor horsepower - 100 hp
- Service Factor - 1.5
- Input Speed - 1,750 rpm
- Desired Accessories - none

WHEN REQUIRED OUTPUT TORQUE IS KNOWN:

A heavy duty bucket elevator is operating 24 hrs/day. The elevator requires a reducer including backstop with a 157 rpm output speed (1,750 rpm input) and 24,000 lb-in output torque. Overhung and thrust loads are not a factor. Reducer will be driven with a 60 hp motor.

Step 1 — Select service factor

From **Table 2** on **pages 10 & 11**, the service factor for a heavy duty bucket elevator 24 hrs/day operation is 1.5.

Step 2 — Calculate desired ratio (D.R.)

$$D.R. = \frac{1,750 \text{ RPM}}{157 \text{ RPM}} = 11.15$$

Step 3 — Select closest nominal ratio (N.R.)

Select from **Table 34** on **page 64**, N.R. = 11.02

$$\text{Output Speed} = \frac{1,750 \text{ RPM}}{11.02} = 159 \text{ RPM}$$

Step 4 — Calculate equivalent output torque (E.O.T.)

Since output torque is known:

$$E.O.T. = 24,000 \text{ (output torque in lb-in)} \times 1.5 \text{ (service factor)} = 36,000 \text{ lb-in}$$

Step 5 — Select reducer

Enter **Table 12 to Table 19**, "Reducer Only Selection", located on **pages 46 to 53**. Nominal ratio is 11.02. The smallest series listed for the E.O.T. calculated in Step 4 (36,000 lb-in) is an Atlas at 36,000 lb-in.

Step 6 — Check thermal capacity

Enter **Table 25**, "Thermal Capacity", on **page 56**. Locate Atlas series, 11.02 ratio in the left-hand column. The input speed is 1,750 RPM and maximum horsepower is 18 without a fan, 63 with a fan.

Step 7 — Check for overhung and thrust loads

Overhung and thrust loads are not a factor in this example.

Step 8 — Check dimensions

Dimensions for the Atlas series are on **page 32**.

Step 9 — Order Planetgear reducer by (see page 15):

- Series Name - Atlas
- Nominal Ratio - 11.02
- Output Torque Rating - 36,000 lb-in
- Input Motor Horsepower - 60 hp
- Service factor - 1.5
- Input Speed - 1,750 rpm
- Desired Accessories - backstop with desired rotation

Service Factor Selections

TABLE 2

SERVICE FACTORS

APPLICATION	SERVICE		APPLICATION	SERVICE		APPLICATION	SERVICE	
	10 HRS/ DAY	24 HRS/ DAY		10 HRS/ DAY	24 HRS/ DAY		10 HRS/ DAY	24 HRS/ DAY
AGITATORS			Clay Working Machinery	1.25	1.50	FANS		
Pure Liquids	1.00	1.25	Pug Mills	1.25	1.50	Centrifugal	1.00	1.25
Liquids & Solids	1.25	1.50	COLLECTORS (Sewage)	1.00	1.25	Cooling Towers	④	④
Liquids - Variable Density	1.25	1.50	COMPRESSORS			Forced Draft	–	1.25
APRON CONVEYORS			Centrifugal	1.00	1.25	Induced Draft	1.25	1.50
Uniformly Loaded or Fed	1.00	1.25	Lobe	1.25	1.50	Large (Mine, etc.)	1.25	1.50
Heavy Duty	1.25	1.50	Reciprocating			Large (Industrial)	1.25	1.50
APRON FEEDERS	1.25	1.50	Multi-Cylinder	1.50	1.75	Light (Small Diameter)	1.00	1.25
ASSEMBLY CONVEYORS			Single Cylinder	2.25	2.50	FEEDERS		
Uniformly Loaded or Fed	1.00	1.25	CONCRETE MIXERS			Apron, Belt	1.25	1.50
Heavy Duty	1.25	1.50	Continuous	1.25	1.50	Disc	1.00	1.25
BALL MILLS	⑤	⑤	Intermittent	1.25	1.50	Reciprocating	1.75	2.00
BARGE HAUL PULLERS	1.75	2.00	CONVEYORS - Uniformly			Screw	1.25	1.50
BARKING			Loaded or Fed: Apron,			FLIGHT		
Drums (coupling connected)	–	2.00	Assembly, Belt, Bucket, Chain			Conveyors, Uniform	1.00	1.25
Mechanical	–	2.00	Flight, Oven, Screw	1.00	1.25	Conveyors, Heavy	1.25	1.50
BAR SCREENS (Sewage)	1.00	1.25	CONVEYOR - Heavy Duty			FOOD INDUSTRY		
BATCHERS (Textile)	1.25	1.50	Not Uniformly Fed: Apron,			Beet Slicers	1.25	1.50
BELT CONVEYORS			Assembly, Belt, Bucket, Chain			Bottling, Can Filling Mach.	1.00	1.25
Uniformly Loaded or Fed	1.00	1.25	Flight, Oven, Screw	1.25	1.50	Cereal Cookers	1.00	1.25
Heavy Duty	1.25	1.50	CONVEYOR - Severe Duty			Dough Mixers, Meat Grinders	1.25	1.50
BELT FEEDERS	1.25	1.50	Live Roll	④	④	GENERATORS (Not Welding)	1.00	1.25
BENDING ROLLS (Machine)	1.25	1.50	Reciprocating, Shaker	1.75	2.00	GRAVITY DISCHARGE		
BLOWERS			COOKERS (Brewing & Distilling)			ELEVATORS	1.00	1.25
Centrifugal	1.00	1.25	(Food)	1.00	1.25	HAMMER MILLS	1.75	2.00
Lobe	1.25	1.50	COOLING TOWER FANS	④	④	HOISTS		
Vane	1.00	1.25	CRANES			Heavy Duty	1.75	2.00
BOTTLING MACHINERY	1.00	1.25	Dry Dock Cranes	①	①	Medium Duty	1.25	1.50
BREWING & DISTILLING			Main Hoist	④	④	Skip Hoist	1.25	1.50
Bottling Machinery	1.00	1.25	Bridge and Trolley Travel	④	④	INDUCED DRAFT FANS	1.25	1.50
Brew Kettles, Cont. Duty	1.00	1.25	CRUSHERS			KILNS	⑤	⑤
Can Filling Machines	1.00	1.25	Ore or Stone	1.75	2.00	LAUNDRY WASHERS & TUMBLERS	1.25	1.50
Cookers, Cont. Duty	1.00	1.25	Sugar	–	1.50	LINE SHAFTS		
Mash Tubs, Cont. Duty	1.00	1.25	DEWATERING SCREENS			Driving Processing Equip.	1.25	1.50
Scale Hoppers, Freq. Starts	1.25	1.50	(Sewage)	1.25	1.50	Other Line Shafts, Light	1.00	1.25
BRICK PRESS (Clay Working)	1.75	2.00	DISC FEEDERS	1.00	1.25	LIVE ROLL CONVEYORS	④	④
BRIQUETTE MACHINES			DISTILLING (See Brewing)			LOBE BLOWERS OR COMPRESSORS	1.25	1.50
(Clay Working)	1.75	2.00	DOUBLE ACTING PUMPS			LOG HAULS (Lumber)		
BUCKET			2 or More Cylinders	1.25	1.50	Incline-well Type	1.75	1.75
Conveyors Uniform	1.00	1.25	Single Cylinder	④	④	LOOMS (Textile)	1.25	1.50
Conveyors Heavy Duty	1.25	1.50	DOUGH MIXER (Food)	1.25	1.50	LUMBER INDUSTRY		
Elevators Cont.	1.00	1.25	DRAW BENCH (Metal Mills)			Barkers - Spindle Feed	1.25	1.50
Elevators Uniform	1.00	1.25	Carriage & Main Drive	1.25	1.50	Barkers - Main Drive	1.75	1.75
Elevators Heavy Duty	1.25	1.50	DREDGES			Carriage Drive	④	④
CALENDERS			Cable Reels, Conveyors	1.25	1.50	Chain - Floor	1.50	1.50
Rubber	1.50	1.50	Cutter Head & Jig Drives	1.75	2.00	Chains - Green	1.50	1.75
Textile	1.25	1.50	Maneuvering Winches, Pumps	1.25	1.50	Conveyors		
CAN FILLING MACHINES	1.00	1.25	Screen Drives	1.75	2.00	Burner	1.25	1.50
CANE KNIVES	1.50	1.50	Stackers, Utility Winches	1.25	1.50	Main or Heavy Duty	1.50	1.50
CARD MACHINES (Textile)	1.25	1.50	DRY DOCK CRANES	①	①	Main Log	1.75	2.00
CAR DUMPERS	1.75	2.00	DRYERS & COOLERS			Re-Saw Merry-Go-Round	1.25	1.50
CAR PULLERS	1.25	1.50	(Mills, Rotary)	–	1.50	Slab	1.75	2.00
CEMENT KILNS	⑤	⑤	DYEING MACHINERY			Transfer	1.25	1.50
CENTRIFUGAL			(Textile)	1.25	1.50	Cut-Off Saws-Chain & Drag	1.50	1.75
Blowers, Compressors,			ELEVATORS			Debarking Drums	1.75	2.00
Discharge Elevators,			Bucket - Uniform Load	1.00	1.25	Feeds - Edger	1.25	1.50
Fans or Pumps	1.00	1.25	Bucket - Heavy Duty	1.25	1.50	Feeds - Gang	1.75	1.75
CHAIN CONVEYORS			Bucket - Continuous	1.00	1.25	Feeds - Trimmer	1.25	1.50
Uniformly Loaded or Fed	1.00	1.25	Centrifugal Discharge	1.00	1.25	Log Deck	2.00	2.00
Heavy Duty	1.25	1.50	Escalators	④	④	Log Hauls- Incline-Well type	1.75	1.75
CHEMICAL FEEDERS			Freight	④	④	Log Turning Devices	1.75	1.75
(Sewage)	1.00	1.25	Gravity Discharge	1.00	1.25	Planer Feed	1.25	1.50
CLARIFIERS	1.00	1.25	Man Lifts, Passenger	④	④	Planer Tilting Hoists	1.50	1.50
CLASSIFIERS	1.25	1.50	EXTRUDERS ⑦	⑦	⑦	Rolls, Live Off Bearing		
CLAY WORKING INDUSTRY						Roll Cases	1.75	1.75
Brick Press	1.75	2.00				Sorting, Table, Tipple Hoist	1.25	1.50
Briquette Machines	1.75	2.00				Transfers - Chain & Craneway	1.50	1.75

① DRY DOCK CRANES (Hammerhead, Rotating and Whirler, Stationary or Moving) for any duration of service: Main Hoist, Auxiliary Hoist, Boom (Lifting): 3.00 S.F.; Rotating (Swing or Slew): 3.00 S.F.; Tracking (Drive Wheels): 3.00 S.F.

② Service factors for paper mill application are applied to nameplate rating of electric motor at the motor rated base speed - consistent with TAPPI Standards.

③ When a super calender operates over a speed range of part constant hp and torque and the constant hp speed range is greater than 1.5:1, use a service factor of 1.0 at base speed. When operating at constant torque over the entire speed range or when the constant hp speed range is less than 1.5:1 a 1.25 factor should be applied.

④ Consult factory.

⑤ See Mills, Rotary.

⑥ Using anti-friction bearings only.

⑦ See Rubber & Plastics Industries.

Service Factor Selections

TABLE 2 CONTINUED

SERVICE FACTORS

APPLICATION	SERVICE		APPLICATION	SERVICE		APPLICATION	SERVICE	
	10 HRS/ DAY	24 HRS/ DAY		10 HRS/ DAY	24 HRS/ DAY		10 HRS/ DAY	24 HRS/ DAY
Tray Devices	1.25	1.50	Couch Rolls	–	1.25	Mills (3 on line)	1.25	1.25
Veneer Lathe Drives	④	④	Cutter	–	2.00	Mixing Mills	1.50	1.50
MACHINE TOOLS			Cylinder Molds	–	1.25	Refiners & Sheeters	1.50	1.50
Auxiliary Drives	1.00	1.25	Dryers ⑥ –			SAND MULLERS	1.25	1.50
Bending Rolls	1.25	1.50	Paper Machine & Conveyor Type	–	1.25	SCREENS		
Main Drives	1.25	1.50	Embosses	–	1.25	Air Washing	1.00	1.25
Notching Press (Belted)	④	④	Extruder	–	1.50	Rotary – Stone or Gravel	1.25	1.50
Plate Planers	1.75	2.00	Foundrinier Rolls–			Traveling Water Intake	1.00	1.25
Punch Press (Geared)	1.75	2.00	Lumberbreaker, Wire Turning, Dandy			SCREW CONVEYORS		
Tapping Machines	1.75	2.00	& Return Rolls	–	1.25	Uniform	1.00	1.25
MANGLE (Textile)	1.25	1.50	Jordan	–	1.50	Heavy Duty or Feeder	1.25	1.50
MAST TUBS (Brewing & Distilling)	1.00	1.25	Kiln Drive	–	1.50	SCUM BREAKERS (Sewage)	1.25	1.50
MEAT GRINDERS (Food)	1.25	1.50	Mt. Hope & Paper Rolls	–	1.25	SEWAGE DISPOSAL		
METAL MILLS			Platter	–	1.50	Bar Screens	1.00	1.25
Draw Bench Carriages & Main Drives	1.25	1.50	Presses (Felt & Suction)	–	1.25	Chemical Feeders	1.00	1.25
Pinch, Dryer & Scrubber			Pulper – continuous	–	1.50	Collectors	1.00	1.25
Rolls Reversing	④	④	Repulper – heavy stock	–	2.00	Dewatering Screens	1.25	1.50
Slitters	1.25	1.50	Vacuum Pumps	–	1.50	Scum Breakers	1.25	1.50
Table Conveyors			Reel (Surface Type)	–	1.25	Slow or Rapid Mixers	1.25	1.50
Non-Reversing			Screens –			Thickeners	1.25	1.50
Group Drives	1.25	1.50	Chip, Rotary	–	1.50	Vacuum Filters	1.25	1.50
Individual	1.75	2.00	Vibrating	–	2.00	SHAKER CONVEYORS	1.75	2.00
Reversing	④	④	Size Press	–	1.25	SINGLE ACTING PUMPS		
Wire Drawing & Flattening Machines	1.25	1.50	Super Calender ③	–	1.25	1 or 2 Cylinders	④	④
Wire Winding Machines	1.25	1.50	Thickener & Washer –			3 or more Cylinders	1.25	1.50
MILLS, ROTARY			AC Motor	–	1.50	SKIP HOIST	1.25	1.50
Ball and Rod Mills			DC Motor	–	1.25	SLAB PUSHERS	1.25	1.50
with Spur Ring Gear	–	2.00	Wind & Unwind Stand	–	1.00	SLITTERS (Metal Mills)	1.25	1.50
with Helical Ring Gear	–	1.50	Winders (Surface Type)	–	1.25	SLUDGE COLLECTORS		
Direct Connected	–	2.00	Yankee Dryers ⑥	–	1.25	(Sewage)	1.00	1.25
Kilns, Dryers, Coolers			PASSENGERS ELEVATORS	④	④	SOAPERS (Textile)	1.25	1.50
Pebble, Plain & Cement Kilns	④	④	PEBBLE MILLS	–	1.50	SPINNERS (Textile)	1.25	1.50
Wedge Bar	–	1.50	PLASTIC INDUSTRY ⑦	⑦	⑦	STEERING GEARS	④	④
Tumbling Barrels	1.75	2.00	PLATE PLANNERS	1.75	2.00	STOKERS	1.00	1.25
MIXERS (Also see Agitators)			PRINTING PRESSES	④	④	STONE CRUSHERS	1.75	2.00
Concrete, Cont.	1.25	1.50	PROPORTIONING PUMPS	1.25	1.50	SUGAR INDUSTRY		
Concrete, Int.	1.25	1.50	PUG MILLS (Clay)	1.25	1.50	Cane, Knives, Crushers	1.50	1.50
Constant Density	1.00	1.25	PULLERS (Barge Haul)	1.75	2.00	Mills (low speed end)	2.00	2.00
Variable Density	1.25	1.50	PUMPS			TABLE CONVEYORS		
NAPPERS (Textile)	1.25	1.50	Centrifugal	1.00	1.25	(Non-Reversing)		
OIL INDUSTRY			Proportioning	1.25	1.50	Group Drives	1.25	1.50
Chillers	1.25	1.50	Reciprocating – Single Action			Individual Drives	1.75	2.00
Oil Well Pumping	④	④	3 or More Cylinders	1.25	1.50	Reversing	④	④
Paraffin Filter Press	1.25	1.50	Reciprocating – Dbl Action			TENTER FRAMES (Textile)	1.25	1.50
Rotary Kilns	1.25	1.50	2 or More Cylinders	1.25	1.50	TEXTILE INDUSTRY		
ORE CRUSHERS	1.75	2.00	Reciprocating – Single Action			Batchers, Calendars	1.25	1.50
OVEN CONVEYORS			1 or 2 Cylinders	④	④	Card Machines	1.25	1.50
Uniform	1.00	1.25	Reciprocating – Dbl Action			Dry Cans, Dryers	1.25	1.50
Heavy Duty	1.25	1.50	1 Cylinder	④	④	Dyeing Machinery	1.25	1.50
PAPER MILLS ②			Rotary Gear, Lobe, Vane	1.00	1.25	Knitting Machinery	④	④
Agitator (Mixer)	–	1.50	PUNCH PRESSES			Looms, Mangles, Nappers, Pads	1.25	1.50
Agitator for Pure Liquors	–	1.25	(Gear Driven)	1.75	2.00	Range Drives	④	④
Barking Drums, Barkers – Mechanical	–	2.00	RECIPROCATING	1.75	2.00	Slashers, Soapers, Spinners	1.25	1.50
Beater	–	1.50	CONVEYORS, FEEDERS			Tenter Frames, Washers, Winders	1.25	1.50
Breaker Stack	–	1.25	RECIPROCATING COMPRESSORS			THICKENERS (Sewage)	1.25	1.50
Calender ⑥	–	1.25	Multi-Cylinder	1.25	1.50	TUMBLING BARRELS	1.75	2.00
Chipper	–	2.00	Single-Cylinder	2.25	2.50	VACUUM FILTERS (Sewage)	1.25	1.50
Chip Feeder	–	1.50	ROD MILLS	⑤	⑤	VANE BLOWERS	1.00	1.25
Coating Rolls	–	1.25	ROTARY			WINCHES (Dredges)	1.25	1.50
Conveyors –			Pumps	1.00	1.25	WINDERS (Textile)	1.25	1.50
Chip, Bark, Chemical	–	1.25	Screens (Stone or Gravel)	1.25	1.50	WINDLASS	④	④
Log (Including Slab)	–	2.00	RUBBER & PLASTICS INDUSTRIES			WIRE		
			Calenders	1.50	1.50	Drawing Machines	1.25	1.50
			Crackers	2.00	2.00	Winding Machines	1.25	1.50
			Mills (2 on line)	1.50	1.50			

① DRY DOCK CRANES (Hammerhead, Rotating and Whirler, Stationary or Moving) for any duration of service: Main Hoist, Auxiliary Hoist, Boom (Lifting): 3.00 S.F.; Rotating (Swing or Slew): 3.00 S.F.; Tracking (Drive Wheels): 3.00 S.F.

② Service factors for paper mill application are applied to nameplate rating of electric motor at the motor rated base speed - consistent with TAPPI Standards.

③ When a super calender operates over a speed range of part constant hp and torque and the constant hp speed range is greater than 1.5:1, use a service factor of 1.0 at base speed. When operating at constant torque over the entire speed range or when the constant hp speed range is less than 1.5:1 a 1.25 factor should be applied.

④ Consult factory.

⑤ See Mills, Rotary.

⑥ Using anti-friction bearings only.

⑦ See Rubber & Plastics Industries.

Thrust and Overhung Loads

THRUST LOADS

Thrust loads applied to reducer shafts through coupling connections often are combined with radial shaft loads. Since this combined loading affects bearing thrust capacities, these values may be obtained by contacting the factory.

OVERHUNG LOADS

The centerline of the overhung load should be as close as possible to the seal cage to minimize bearing load and improve bearing life. The formula for determining overhung load in pounds is as follows:

$$\text{Overhung Load in Pounds} = \frac{126,000 \times \text{HP} \times F_c \times L_f}{\text{P.D.} \times \text{RPM}}$$

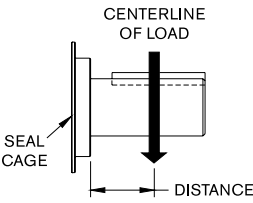

F_c = Load Connection Factor
 Sprocket (1.00) ①
 Machined Pinion & Gear (1.25)
 Timing Belt (1.30)
 V-Belt (1.50)
 Flat Belt (2.50)

L_f = Load Location Factor
 H.S.S. — **Table 21** on **page 54**
 L.S.S. — **Table 22** on **page 54**

① Refer all multiple chain sprocket and pinion mounted applications to the factory for deflection analysis.

Capacities listed on pages:

Table 23 on **page 55** High Speed Shaft

Table 24 on **page 55** Low Speed Shaft

where:

- HP = Horsepower without service factor
- F_c = Load connection factor - see above
- L_f = Load location factor - see above
- P.D. = Pitch Diameter in inches
- RPM = Shaft revolutions per minute

If the actual overhung load exceeds the published capacity, the following may be assistance to reduce the overhung load on the shaft bearings.

1. Increase the pitch diameter of sheave or sprocket.
2. Locate the sprocket or belt closer to the seal cage.
3. Go to the next larger reducer series.

EXAMPLE – HIGH SPEED SHAFT

REQUIRED:

A 10 hp, 1,750 rpm motor with 5.5 inch pitch diameter sheave is V-belt connected to an 8.2 inch sheave mounted on an Atlas series reducer having a ratio of 54.45, an output torque capacity of 30,000 lb-in and a 21.5 rpm output speed. The centerline of the sheave on the reducer is mounted 2 inches from the seal cage. Calculate the high speed shaft overhung load.

SOLUTION:

$$\text{Reducer input RPM} = \frac{1,750 \times 5.5}{8.2} = 1,170 \text{ RPM}$$

for L_f reference **Table 21** on **page 54**

$$\text{O.H.L.} = \frac{126,000 \times 10 \times 1.5 \times 1.02}{8.2 \times 1,170} = 201 \text{ lbs.}$$

Table 21, page 54 - 1,170 rpm yields an overhung load capacity of 1,060 pounds for the Atlas series reducer. The actual load of 201 pounds is less than the capacity rating and is acceptable for this selection.

EXAMPLE – LOW SPEED SHAFT

The load location factors (L_f) are shown in **Table 22, page 54**. The overhung load capacity ratings for low speed shafts are listed in **Table 24, page 55**.

REQUIRED:

A 10 hp, 1,750 rpm motor is directly connected to a Mars reducer having a ratio of 24.00 (72.92 rpm output). A 120B21 10.064 inch pitch diameter roller chain sprocket is mounted so that the centerline of the load is 2-3/4 inches from the seal cage. Calculate the low speed shaft overhung load.

SOLUTION:

$$\text{O.H.L.} = \frac{126,000 \times 10 \times 1.5 \times 1.04}{10.064 \times 72.92} = 1,786 \text{ lbs.}$$

The overhung load rating listed in **Table 24, page 55**, for the Mars reducer at a ratio of 24.00 is 3,620 pounds. The actual load of 1,786 is less than the rated capacity and is acceptable for this application.

Published values of overhung loads in **Table 23 & Table 24** are based on the load being applied at 1 shaft diameter away from the seal cage.

Reducer Order Form

Reducer Order Form

The following information is required when ordering a Planetgear speed reducer:

Reducer Series:

- | | | | | |
|--------------------------------------|-------------------------------------|---------------------------------------|---------------------------------------|-------------------------------------|
| <input type="checkbox"/> Mercury | <input type="checkbox"/> Mars | <input type="checkbox"/> Venus | <input type="checkbox"/> Atlas | <input type="checkbox"/> Luna |
| <input type="checkbox"/> Earth | <input type="checkbox"/> Delta | <input type="checkbox"/> Neptune | <input type="checkbox"/> Neptune Plus | <input type="checkbox"/> Orion Plus |
| <input type="checkbox"/> Saturn Plus | <input type="checkbox"/> Titan Plus | <input type="checkbox"/> Jupiter Plus | | |

Mounting Orientation:

- | | |
|--|--|
| <input type="checkbox"/> Horizontal | <input type="checkbox"/> Inclined |
| | <input type="checkbox"/> Degrees High Speed Shaft Up |
| | <input type="checkbox"/> Degrees Low Speed Shaft Up |
| <input type="checkbox"/> Vertical | <input type="checkbox"/> Rotated |
| <input type="checkbox"/> High Speed Shaft Up | <input type="checkbox"/> Degrees Clockwise Rotation (viewing Low Speed Shaft) |
| <input type="checkbox"/> Low Speed Shaft Up | <input type="checkbox"/> Degrees Counterclockwise Rotation (viewing Low Speed Shaft) |

Rating Information:

Torque Rating: _____	Motorized:	Motor HP: _____
Input RPM: _____		Service Class: _____
Ratio: _____	Non-Motorized:	Service HP: _____
Output RPM: _____		Service Factor: _____

Motorized Reducers:

Basic Configuration

- Scoop Mount with Omega coupling (Frame Size _____)
- or
- Input C-face (Frame Size _____)

Standard Reducers / Non-motorized

Basic Configuration

- Reducer Only
- Top Mount (Frame Size _____)
- Baseplate (Frame Size _____)

Optional Accessories

- Coupling Guard
- Fan & Shroud
- Backstop (Rotation CW or CCW)
- Slidebase
- Vertical Modification
- High Temperature Seals
- Extended Shafts
- Motor

Optional Accessories

- Couplings
- Coupling Guard
- Fan & Shroud
- Backstop (Rotation CW or CCW)
- Slidebase
- Vertical Modification
- High Temperature Seals
- Extended Shafts
- Motor

1750 RPM - Class I - Service Factor = 1.00

TABLE 3

Reducers with standard input shaft ①
 Low speed shaft torque rating (1000 lb-in) ②
 (Horizontal mounting)

Reduction	Nominal Ratio	Approx. Output RPM	Motor Horsepower & Frame Size										
			1 HP 143T	1.5 HP 145T	2 HP 145T	3 HP 182T	5 HP 184T	7.5 HP 213T	10 HP 215T	15 HP 254T	20 HP 256T	25 HP 284T	
Single	3.53	496	MERC 4	MERC 4	MERC 4	MERC 4	MERC 4	MERC 4	MERC 4	MERC 4	MERC 4	MERC 4	
	4.39	399	MERC 4	MERC 4	MERC 4	MERC 4	MERC 4	MERC 4	MERC 4	MERC 4	MERC 4	MERC 4	
	6.12	286	MERC 3	MERC 3	MERC 3	MERC 3	MERC 3	MERC 3	MERC 3	MERC 3	MARS 7	MARS 7	
Double	9.30	188	MARS 10	MARS 10	MARS 10	MARS 10	MARS 10	MARS 10	MARS 10	MARS 10	MARS 10	MARS 10	
	11.02	159	MERC 5	MERC 5	MERC 5	MERC 5	MERC 5	MERC 5	MERC 5	MERC 5	MARS 10	MARS 10	
	13.85	126	MERC 6	MERC 6	MERC 6	MERC 6	MERC 6	MERC 6	MERC 6	MERC 6	MARS 12	MARS 12	
	17.21	102	MERC 6	MERC 6	MERC 6	MERC 6	MERC 6	MERC 6	MERC 6	MERC 6	MARS 13	MARS 13	
	20.41	86	MERC 6	MERC 6	MERC 6	MERC 6	MERC 6	MERC 6	MERC 6	MARS 12	MARS 12	VENS 23	
	24.00	73	MERC 7	MERC 7	MERC 7	MERC 7	MERC 7	MERC 7	MERC 7	MARS 14	MARS 14	VENS 22	
	31.63	55	MERC 6	MERC 6	MERC 6	MERC 6	MERC 6	MERC 6	MARS 13	MARS 13	VENS 19	ATLS 32	ATLS 32
	36.56	48	MERC 7	MERC 7	MERC 7	MERC 7	MERC 7	MERC 7	MARS 15	MARS 15	VENS 23	ATLS 41	ATLS 41
	43.78	40	MERC 5d	MERC 5d	MERC 5d	MERC 5d	MARS 10d	MARS 10d	MARS 16	MARS 16	VENS 24	ATLS 41	ATLS 41
54.45	32	MERC 8	MERC 8	MERC 8	MERC 8	MARS 17	MARS 17	MARS 17	MARS 17	VENS 24	ATLS 42	LUNA 51	
Triple	64.42	27	MERC 8	MERC 8	MERC 8	MERC 8	MARS 17	MARS 17	MARS 17	VENS 24	ATLS 42	LUNA 51	ERTH 72
	69.63	25	MERC 7	MERC 7	MERC 7	MERC 7	MARS 17	MARS 17	MARS 17	VENS 22	ATLS 39	LUNA 49	ERTH 68
	80.01	22	MERC 8	MERC 8	MERC 8	MERC 8	MARS 17	MARS 17	MARS 17	VENS 24	ATLS 42	ERTH 74	ERTH 74
	91.41	19.1	MERC 8	MERC 8	MERC 8	MARS 17	MARS 17	MARS 17	ATLS 38	ATLS 38	ERTH 54	NEP+ 211	NEP+ 211
	99.38	17.6	MERC 7	MERC 7	MERC 7	MARS 15	MARS 15	MARS 15	ATLS 40	ATLS 40	LUNA 49	ERTH 70	PLRS 105
	111.5	15.7	MERC 8	MERC 8	MERC 8	MARS 17	MARS 17	MARS 17	ATLS 42	ATLS 42	ERTH 74	ERTH 74	PLRS 120
	121.4	14.4	MERC 7q	MERC 7q	MARS 17q	MARS 17q	MARS 17q	MARS 17q	ATLS 38q	LUNA 51q	ERTH 74q	PLRS 120q	PLRS 120q
	138.5	12.6	MERC 7	MARS 15	MARS 15	MARS 15	MARS 15	MARS 15	ATLS 39	LUNA 49	ERTH 70	PLRS 110	DELT 144
	159.8	11.0	MERC 8	MERC 8	MARS 17	MARS 17	MARS 17	MARS 17	ATLS 43q	ATLS 43q	ERTH 74q	PLRS 120q	DELT 154q
	193.1	9.1	MERC 7	MARS 15	MARS 15	VENS 20	ATLS 33	ERTH 60	ERTH 60	ERTH 76q	PLRS 120q	DELT 154q	DELT 154q
	206.2	8.5	MERC 8	MARS 17	MARS 17	VENS 24	ATLS 43	ERTH 76	ERTH 76	ERTH 76	PLRS 120	DELT 154	NEP+ 226
Quadruple	238.2	7.3	MERC 8	MARS 17	MARS 17	VENS 24	ATLS 43	ERTH 76	ERTH 76	ERTH 76	PLRS 120	DELT 154	NEP+ 227
	265.4	6.6	MARS 10t	MARS 17	MARS 17	ATLS 43	ATLS 43	ATLS 43	ATLS 43	ERTH 76	PLRS 120	DELT 154	NEP+ 227
	295.7	5.9	MARS 17	MARS 17	VENS 24	ATLS 43	LUNA 51	ERTH 72	PLRS 115	DELT 147	NEP+ 213	ORN+ 316	
	330.1	5.3	MARS 18	MARS 18	VENS 23	ATLS 40	ERTH 76	PLRS 120	PLRS 120	NEP+ 228	NEP+ 228	ORN+ 316	
	369.8	4.7	MARS 18	VENS 24	VENS 24	ATLS 43	ERTH 76	PLRS 120	PLRS 120	NEP+ 229	ORN+ 274	ORN+ 440	
	412.1	4.2	MARS 18	VENS 24	ATLS 43	ATLS 43	ERTH 72	PLRS 115	DELT 148	NEP+ 215	ORN+ 316	SAT+ 430	
	459.0	3.8	MARS 16	VENS 23	ATLS 40	LUNA 50	ERTH 76	PLRS 120	DELT 154	NEP+ 230	ORN+ 316	SAT+ 440	
	532.5	3.3	MARS 18	ATLS 43	ATLS 43	LUNA 51	PLRS 115	DELT 149	NEP+ 217	NEP+ 316	SAT+ 430	TTN+ 587	
	617.9	2.8	VENS 23	ATLS 40	LUNA 51	ERTH 76	PLRS 120	NEP+ 232	NEP+ 232	SAT+ 440	SAT+ 440	TTN+ 570	
	660.6	2.6	ERTH 76qu	ERTH 76qu	ERTH 76qu	ERTH 76qu	PLRS 120qu	NEP+ 232qu	NEP+ 232qu	SAT+ 440qu	SAT+ 440qu	TTN+ 632qu	
	741.2	2.4	VENS 24	ATLS 43	ERTH 72	PLRS 115qu	DELT 150	NEP+ 219	NEP+ 316	SAT+ 430	TTN+ 594	JPT+ 890qu	
	900.3	1.9	ATLS 40	LUNA 51	ERTH 76qu	PLRS 115qu	DELT 154qu	NEP+ 234qu	ORN+ 316qu	SAT+ 440qu	TTN+ 638qu	JPT+ 892qu	
	1057.0	1.7	LUNA 42	ERTH 60	PLRS 120qu	PLRS 120qu	NEP+ 183	ORN+ 316qu	SAT+ 440qu	TTN+ 640qu	JPT+ 899qu	JPT+ 899qu	
Quintuple	1255.0	1.4	LUNA 42q	ERTH 76	PLRS 115	DELT 154	NEP+ 236	SAT+ 440	SAT+ 440	TTN+ 643	JPT+ 903		
	1785.0	1.0	ERTH 72	PLRS 115	PLRS 115	NEP+ 238	ORN+ 316	SAT+ 440	SAT+ 440	TTN+ 591	JPT+ 905		

Shaded areas that are **bold** require an electric fan.
 Shaded areas that are **bold and italicized** require an alternate lubricant to achieve selection, contact factory for lubrication specification.
 Shaded areas require a cooling option.

① Selections are based on 1750 RPM, NEMA B, T-Frame motors. If other motor types, speeds or HP's > 250 are required, refer application to factory. Additional ratios are available as standard items. Contact Rexnord for application details.

② Example: "VENS 19" requires a Venus size reducer rated for 19,000 lb-in torque.

d = double reduction t = triple reduction q = quadruple reduction qu = quintuple reduction

1750 RPM - Class I - Service Factor = 1.00

TABLE 3 CONTINUED

Reducers with standard input shaft ①
 Low speed shaft torque rating (1000 lb-in) ②
 (Horizontal mounting)

Reduction	Nominal Ratio	Approx. Output RPM	Motor Horsepower & Frame Size										
			30 HP 286T	40 HP 324T	50 HP 326T	60 HP 364T	75 HP 365T	100 HP 405T	125 HP 444T	150 HP 445T	200 HP	250 HP	
Single	3.53	496	MERC 4	VENS 16	VENS 16	VENS 16	VENS 16	VENS 16	ERTH 42	NEPT 75			
	4.39	399	MARS 7	MARS 7	VENS 16	VENS 16	VENS 16	VENS 16	VENS 16	ERTH 44	PLRS 52	NEPT 80	
	6.12	286	MARS 7	VENS 17	VENS 17	VENS 17	VENS 17	VENS 17	ATLS 30	ERTH 46	NEPT 85	NEPT 85	NEPT 85
Double	9.30	188	MARS 10	ATLS 26	ATLS 26	ATLS 26	ATLS 26	ATLS 26	ERTH 50	PLRS 64	NEPT 110	NEPT 110	
	11.02	159	VENS 21	VENS 21	VENS 21	ATLS 36	ATLS 36	ERTH 60	PLRS 80	NEPT 110	ORN+ 241		
	13.85	126	VENS 22	VENS 22	ATLS 38	ATLS 38	ATLS 38	ERTH 64	PLRS 85	PLRS 85	NEPT 115	SAT+ 260	
	17.21	102	VENS 21	ATLS 38	ATLS 38	ATLS 38	LUNA 47	ERTH 64	PLRS 85	NEPT 120	NEPT 120	ORN+ 287	
	20.41	86	VENS 23	ATLS 38	ATLS 38	LUNA 41	ERTH 70	ERTH 70	PLRS 100	PLRS 100	PLRS 100	NEP+ 214	
	24.00	73	ATLS 38	ATLS 38	LUNA 48	ERTH 66	ERTH 66	PLRS 90	DELT 139	DELT 139	DELT 139	NEP+ 201	ORN+ 299
	31.63	55	LUNA 39	ERTH 56	ERTH 66t	ERTH 66t	PLRS 80t	NEPT 120	NEP+ 162	SAT+ 360t	TTN+ 512	TTN+ 512	
	36.56	48	ATLS 41	ERTH 70	ERTH 70	PLRS 110	PLRS 110	NEP+ 184	ORN+ 274	SAT+ 360	SAT+ 360	SAT+ 360	
	43.78	40	LUNA 51	ERTH 72	PLRS 115	PLRS 115	PLRS 115	NEP+ 184	SAT+ 380	SAT+ 380	SAT+ 380	SAT+ 380	
	54.45	32	ERTH 72	PLRS 120	PLRS 120	PLRS 120	DELT 151	NEP+ 219	ORN+ 313	SATN+ 400	SATN+ 400	SATN+ 400	
Triple	64.42	27	ERTH 72	PLRS 120	PLRS 120	DELT 135	NEP+ 184	ORN+ 274	ORN+ 274	SAT+ 420	TTN+ 594	JPT+ 807	
	69.63	25	PLRS 105	PLRS 105	DELT 142	DELT 142	NEP+ 206	ORN+ 315	ORN+ 315	SAT+ 400	TTN+ 543	JPT+ 703	
	80.01	22	PLRS 120	PLRS 120	DELT 152	NEP+ 221	NEP+ 221	ORN+ 315	SAT+ 430	SAT+ 430	TTN+ 598		
	91.41	19.1	NEP+ 211	NEP+ 211	NEP+ 211	NEP+ 211	ORN+ 260	SAT+ 450	SAT+ 450	SAT+ 450	TTN+ 599	JPT+ 706	
	99.38	17.6	PLRS 105	DELT 143	NEP+ 208	NEP+ 208	ORN+ 316	SAT+ 420	SAT+ 420	TTN+ 550	JPT+ 819	JPT+ 819	
	111.5	15.7	PLRS 120	NEP+ 223	NEP+ 223	NEP+ 223	SAT+ 440	SAT+ 440	TTN+ 536	JPT+ 712			
	121.4	14.4	PLRS 120q	NEP+ 223q	NEP+ 223q	ORN+ 274q	SAT+ 440q	SAT+ 440q	TTN+ 605q	TTN+ 605q	JPT+ 825		
	138.5	12.6	DELT 144	NEP+ 210	ORN+ 315	ORN+ 315	SAT+ 420	TTN+ 557	JPT+ 840	JPT+ 840			
	159.8	11.0	DELT 154q	NEP+ 224q	ORN+ 316q	ORN+ 316q	SAT+ 440q	TTN+ 608q	JPT+ 724q				
	193.1	9.1	NEP+ 226q	ORN+ 316q	ORN+ 316q	SAT+ 440q	TTN+ 611q	TTN+ 611q					
Quadruple	206.2	8.5	NEP+ 226	ORN+ 274	SAT+ 440	SAT+ 440	TTN+ 613	JPT+ 730					
	238.2	7.3	NEP+ 227	ORN+ 316	SAT+ 440	TTN+ 615	TTN+ 615	JPT+ 849					
	265.4	6.6	ORN+ 316	SAT+ 440	SAT+ 440	TTN+ 617	JPT+ 852						
	295.7	5.9	ORN+ 316	SAT+ 420	TTN+ 573	TTN+ 573	JPT+ 856						
	330.1	5.3	ORN+ 316	SAT+ 440	TTN+ 620	TTN+ 620	JPT+ 858						
	369.8	4.7	SAT+ 440	TTN+ 622	TTN+ 622	JPT+ 863							
	412.1	4.2	SAT+ 430	TTN+ 580	JPT+ 865	JPT+ 865							
	459.0	3.8	SAT+ 440	TTN+ 626	JPT+ 869								
	532.5	3.3	TTN+ 587	JPT+ 874	JPT+ 874								
	617.9	2.8	JPT+ 761										
660.6	2.6	TTN+ 632qu											
741.2	2.4	JPT+ 890qu											
900.3	1.9	JPT+ 892qu											
1057.0	1.7												
Quintuple	1255.0	1.4											
	1785.0	1.0											

Shaded areas that are **bold** require an electric fan.
 Shaded areas that are **bold and italicized** require an alternate lubricant to achieve selection, contact factory for lubrication specification.
 Shaded areas require a cooling option.

① Selections are based on 1750 RPM, NEMA B, T-Frame motors. If other motor types, speeds or HP's > 250 are required, refer application to factory. Additional ratios are available as standard items. Contact Rexnord for application details.

② **Example: "VENS 19" requires a Venus size reducer rated for 19,000 lb-in torque.**

d = double reduction t = triple reduction q = quadruple reduction qu = quintuple reduction

1750 RPM - Service Factor = 1.25

TABLE 4

Reducers with standard input shaft ①
 Low speed shaft torque rating (1000 lb-in) ②
 (Horizontal mounting)

Reduction	Nominal Ratio	Approx. Output RPM	Motor Horsepower & Frame Size										
			1 HP 143T	1.5 HP 145T	2 HP 145T	3 HP 182T	5 HP 184T	7.5 HP 213T	10 HP 215T	15 HP 254T	20 HP 256T	25 HP 284T	
Single	3.53	496	MERC 4	MERC 4	MERC 4	MERC 4	MERC 4	MERC 4	MERC 4	MERC 4	MERC 4	MARS 8	
	4.39	399	MERC 4	MERC 4	MERC 4	MERC 4	MERC 4	MERC 4	MERC 4	MERC 4	MARS 7	MARS 7	
	6.12	286	MERC 3	MERC 3	MERC 3	MERC 3	MERC 3	MERC 3	MERC 3	MERC 3	MARS 7	VENS 17	
Double	9.30	188	MARS 10	MARS 10	MARS 10	MARS 10	MARS 10	MARS 10	MARS 10	MARS 10	MARS 10	ATLS 26	
	11.02	159	MERC 5	MERC 5	MERC 5	MERC 5	MERC 5	MERC 5	MERC 5	MERC 5	MARS 10	VENS 21	
	13.85	126	MERC 6	MERC 6	MERC 6	MERC 6	MERC 6	MERC 6	MERC 6	MERC 6	MARS 12	VENS 22	
	17.21	102	MERC 6	MERC 6	MERC 6	MERC 6	MERC 6	MERC 6	MERC 6	MARS 13	MARS 13	VENS 21	
	20.41	86	MERC 6	MERC 6	MERC 6	MERC 6	MERC 6	MERC 6	MARS 12	MARS 12	VENS 23	VENS 23	
	24.00	73	MERC 7	MERC 7	MERC 7	MERC 7	MERC 7	MERC 7	MARS 14	MARS 14	VENS 22	VENS 22	
	31.63	55	MERC 6	MERC 6	MERC 6	MERC 6	MARS 13	MARS 13	MARS 13	MARS 13	ATLS 32	ATLS 32	LUNA 39
Triple	36.56	48	MERC 7	MERC 7	MERC 7	MERC 7	MARS 15	MARS 15	MARS 15	VENS 41	VENS 41	ATLS 41	
	43.78	40	MERC 5d	MERC 5d	MERC 5d	MERC 7	MARS 10d	MARS 16	MARS 16	VENS 24	ATLS 41	ATLS 41	
	54.45	32	MERC 8	MERC 8	MERC 8	MERC 8	MARS 17	MARS 17	MARS 17	VENS 24	ATLS 42	LUNA 51	
	64.42	27	MERC 8	MERC 8	MERC 8	MARS 17	MARS 17	MARS 17	VENS 24	ATLS 42	ATLS 42	ERTH 72	
	69.63	25	MERC 7	MERC 7	MERC 7	MARS 17	MARS 17	MARS 17	VENS 22	ATLS 39	LUNA 49	ERTH 68	
	80.01	22	MERC 8	MERC 8	MERC 8	MARS 17	MARS 17	MARS 17	ATLS 42	ATLS 42	LUNA 51	ERTH 74	
	91.41	19.1	MERC 8	MERC 8	MERC 8	MARS 17	ATLS 38	ATLS 38	ATLS 38	ERTH 54	NEP+ 211	NEP+ 211	NEP+ 211
	99.38	17.6	MERC 7	MERC 7	MARS 15	MARS 15	MARS 15	MARS 15	VENS 23	ATLS 40	LUNA 49	ERTH 70	PLRS 105
	111.5	15.7	MERC 8	MERC 8	MARS 17	MARS 17	MARS 17	MARS 17	VENS 24	ATLS 42	ERTH 74	ERTH 74	PLRS 120
	121.4	14.4	MERC 7q	MARS 17q	MARS 17q	MARS 17q	MARS 17q	MARS 17q	VENS 24q	ATLS 38q	LUNA 51q	ERTH 74q	PLRS 120q
	138.5	12.6	MERC 7	MARS 15	MARS 15	MARS 15	MARS 15	MARS 15	VENS 23	ATLS 39	ERTH 70	PLRS 110	DELTA 144
159.8	11.0	MERC 8	MARS 17	MARS 17	MARS 17	MARS 17	MARS 17	VENS 24q	ATLS 43q	ERTH 74q	PLRS 120q	DELTA 144q	
Quadruple	193.1	9.1	MARS 15	MARS 15	VENS 20	ATLS 33	LUNA 40	ERTH 60	ERTH 60	ERTH 60	PLRS 120q	DELTA 154q	NEP+ 226q
	206.2	8.5	MERC 8	MARS 17	MARS 17	ATLS 43	ATLS 43	ERTH 76	PLRS 120	DELTA 154	NEP+ 226	NEP+ 226	NEP+ 226
	238.2	7.3	MARS 17	MARS 17	VENS 24	ATLS 43	LUNA 51	ERTH 76	PLRS 120	DELTA 154	NEP+ 227	NEP+ 227	ORN+ 316
	265.4	6.6	MARS 17	MARS 17	VENS 24	ATLS 43	ERTH 76	PLRS 120	PLRS 120	NEP+ 227	NEP+ 227	NEP+ 227	ORN+ 316
	295.7	5.9	MARS 17	VENS 24	VENS 24	ATLS 43	ERTH 72	PLRS 115	DELTA 147	NEP+ 213	ORN+ 316	ORN+ 316	ORN+ 316
	330.1	5.3	MARS 18	VENS 23	ATLS 40	ATLS 40	ERTH 76	PLRS 120	DELTA 154	NEP+ 228	ORN+ 316	ORN+ 316	SAT+ 440
	369.8	4.7	MARS 18	VENS 24	ATLS 43	LUNA 51	ERTH 76	PLRS 120	NEP+ 229	NEP+ 229	SAT+ 440	SAT+ 440	SAT+ 440
	412.1	4.2	MARS 18	ATLS 43	ATLS 43	LUNA 51	PLRS 115	DELTA 148	NEP+ 215	ORN+ 316	ORN+ 316	SAT+ 430	SAT+ 430
	459.0	3.8	VENS 23	ATLS 40	ATLS 40	ERTH 76	PLRS 120	DELTA 154	NEP+ 230	ORN+ 316	SAT+ 440	SAT+ 440	TTN+ 626
	532.5	3.3	VENS 24	ATLS 43	ATLS 43	ERTH 72	PLRS 115	NEP+ 217	NEP+ 217	NEP+ 217	SAT+ 430	TTN+ 587	TTN+ 587
Quintuple	617.9	2.8	ATLS 40	ATLS 40	LUNA 51	ERTH 76	DELTA 133	NEP+ 232	ORN+ 268	SAT+ 440	TTN+ 570	JPT+ 761	
	660.6	2.6	ERTH 76qu	ERTH 76qu	ERTH 76qu	PLRS 120qu	NEP+ 232qu	NEP+ 232qu	ORN+ 274qu	SAT+ 440qu	TTN+ 632qu	JPT+ 763	
	741.2	2.4	ATLS 43	LUNA 45	ERTH 72	PLRS 115	NEP+ 219	NEP+ 219	ORN+ 316	ORN+ 316	JPT+ 890qu	JPT+ 890qu	
	900.3	1.9	ATLS 40	ERTH 76qu	PLRS 115qu	PLRS 115qu	NEP+ 234qu	ORN+ 316qu	SAT+ 440qu	SAT+ 440qu	TTN+ 638qu	JPT+ 892qu	
	1057.0	1.7	ERTH 60	PLRS 120qu	PLRS 120qu	DELTA 154qu	ORN+ 316qu	SAT+ 440qu	SAT+ 440qu	TTN+ 640qu	JPT+ 899qu	JPT+ 899qu	
Quintuple	1255.0	1.4	ERTH 76	PLRS 115	PLRS 115	DELTA 154	ORN+ 274	SAT+ 440	TTN+ 643	TTN+ 643	JPT+ 903	JPT+ 903	
	1785.0	1.0	ERTH 72	PLRS 115	DELTA 149	NEP+ 238	SAT+ 440	SAT+ 440	TTN+ 591	JPT+ 905	JPT+ 905	JPT+ 905	

Shaded areas that are **bold** require an electric fan.
 Shaded areas that are **bold and italicized** require an alternate lubricant to achieve selection, contact factory for lubrication specification.
 Shaded areas require a cooling option.

① Selections are based on 1750 RPM, NEMA B, T-Frame motors. If other motor types, speeds or HP's > 250 are required, refer application to factory. Additional ratios are available as standard items. Contact Rexnord for application details.

② Example: "VENS 19" requires a Venus size reducer rated for 19,000 lb-in torque.

d = double reduction t = triple reduction q = quadruple reduction qu = quintuple reduction

1750 RPM - Service Factor = 1.25

TABLE 4 CONTINUED

Reducers with standard input shaft ①
 Low speed shaft torque rating (1000 lb-in) ②
 (Horizontal mounting)

Reduction	Nominal Ratio	Approx. Output RPM	Motor Horsepower & Frame Size										
			30 HP 286T	40 HP 324T	50 HP 326T	60 HP 364T	75 HP 365T	100 HP 405T	125 HP 444T	150 HP 445T	200 HP	250 HP	
Single	3.53	496	MARS 8	VENS 16	VENS 16	VENS 16	<i>VENS 16</i>	<i>ERTH 42</i>	<i>NEPT 75</i>				
	4.39	399	MARS 7	VENS 16	VENS 16	VENS 16	VENS 16	<i>ATLS 28</i>	<i>ERTH 44</i>	<i>PLRS 52</i>	NEPT 80		
	6.12	286	VENS 17	VENS 17	VENS 17	VENS 17	<i>ATLS 30</i>	<i>ATLS 30</i>	ERTH 44	NEPT 85	NEPT 85	<i>NEPT 85</i>	
Double	9.30	188	ATLS 26	ATLS 26	ATLS 26	<i>ATLS 26</i>	<i>ERTH 50</i>	<i>ERTH 50</i>	<i>PLRS 64</i>	<i>NEPT 110</i>	<i>NEPT 110</i>		
	11.02	159	VENS 21	VENS 31	ATLS 36	ATLS 36	<i>ATLS 36</i>	<i>ERTH 60</i>	<i>PLRS 80</i>	NEPT 110	ORN+ 241		
	13.85	126	VENS 22	ATLS 38	ATLS 38	ATLS 38	LUNA 50	<i>ERTH 64</i>	<i>PLRS 85</i>	NEP+ 209	NEP+ 209	TTN+ 555	
	17.21	102	ATLS 38	ATLS 38	ATLS 38	LUNA 47	ERTH 64	PLRS 85	DELT 138	NEP+ 199	NEP+ 199	ORN+ 287	
	20.41	86	ATLS 38	ATLS 38	LUNA 41	ERTH 70	ERTH 70	PLRS 100	DELT 121	NEP+ 214	NEP+ 214	SAT+ 280	
	24.00	73	ATLS 38	LUNA 48	ERTH 66	ERTH 66	PLRS 90	DELT 139	DELT 139	NEP+ 201	NEP+ 201	ORN+ 299	
	31.63	55	ERTH 56	ERTH 66t	ERTH 66t	PLRS 80t	NEP+ 162	NEP+ 162	SAT+ 360t	SAT+ 360t	TTN+ 512	TTN+ 512	
	36.56	48	LUNA 51	ERTH 70	PLRS 110	PLRS 110	DELT 150	NEP+ 184	ORN+ 274	SAT+ 360			
	43.78	40	ERTH 72	PLRS 115	PLRS 115	PLRS 115	DELT 150	ORN+ 311	ORN+ 311	SAT+ 380			
54.45	32	ERTH 72	PLRS 120	PLRS 120	DELT 151	NEP+ 219	ORN+ 313	ORN+ 313	SAT+ 400		TTN+ 593		
Triple	64.42	27	PLRS 120	PLRS 120	DELT 135	NEP+ 184	ORN+ 274	ORN+ 274	SAT+ 420	SAT+ 420	TTN+ 594	<i>JPT+ 807</i>	
	69.63	25	PLRS 105	DELT 142	NEP+ 206	NEP+ 206	ORN+ 315	ORN+ 315	SAT+ 400	TTN+ 543	<i>JPT+ 811</i>		
	80.01	22	PLRS 120	DELT 152	NEP+ 221	NEP+ 221	ORN+ 315	SAT+ 430	SAT+ 430	TTN+ 598	<i>JPT+ 703</i>		
	91.41	19.1	NEP+ 211	NEP+ 211	NEP+ 211	ORN+ 260	SAT+ 450	SAT+ 450	SAT+ 450	TTN+ 599			
	99.38	17.6	DELT 143	NEP+ 208	NEP+ 208	ORN+ 316	ORN+ 316	SAT+ 420	TTN+ 550	JPT+ 819	<i>JPT+ 819</i>		
	111.5	15.7	NEP+ 223	NEP+ 223	ORN+ 254	SAT+ 440	SAT+ 440	TTN+ 536	JPT+ 712	JPT+ 712			
	121.4	14.4	DELT 153q	NEP+ 223q	ORN+ 274q	SAT+ 440q	SAT+ 440q	TTN+ 605q	JPT+ 825	JPT+ 825			
	138.5	12.6	NEP+ 210	ORN+ 315	ORN+ 315	SAT+ 420	TTN+ 557	JPT+ 840	JPT+ 840				
	159.8	11.0	NEP+ 224q	ORN+ 316q	ORN+ 316q	SAT+ 440q	TTN+ 608q	JPT+ 724					
	193.1	9.1	NEP+ 226q	ORN+ 316q	SAT+ 440q	TTN+ 611q	TTN+ 611q						
Quadruple	206.2	8.5	ORN+ 274	SAT+ 440	SAT+ 440	TTN+ 613	JPT+ 730						
	238.2	7.3	ORN+ 316	SAT+ 440	TTN+ 615	TTN+ 615	JPT+ 849						
	265.4	6.6	SAT+ 440	SAT+ 440	TTN+ 617	JPT+ 852	JPT+ 852						
	295.7	5.9	SAT+ 420	TTN+ 573	JPT+ 856	JPT+ 856							
	330.1	5.3	SAT+ 440	TTN+ 620	JPT+ 858	JPT+ 858							
	369.8	4.7	SAT+ 440	TTN+ 622	JPT+ 863								
	412.1	4.2	TTN+ 580	JPT+ 865	JPT+ 865								
	459.0	3.8	TTN+ 626	JPT+ 869									
	532.5	3.3	JPT+ 874	JPT+ 874									
	617.9	2.8	JPT+ 761										
	660.6	2.6											
	741.2	2.4											
	900.3	1.9											
1057.0	1.7												
Quintuple	1255.0	1.4											
	1785.0	1.0											

Shaded areas that are **bold** require an electric fan.

Shaded areas that are **bold and italicized** require an alternate lubricant to achieve selection, contact factory for lubrication specification.

Shaded areas require a cooling option.

① Selections are based on 1750 RPM, NEMA B, T-Frame motors. If other motor types, speeds or HP's > 250 are required, refer application to factory. Additional ratios are available as standard items. Contact Rexnord for application details.

② **Example: "VENS 19" requires a Venus size reducer rated for 19,000 lb-in torque.**

d = double reduction t = triple reduction q = quadruple reduction qu = quintuple reduction

1750 RPM - Class II - Service Factor = 1.40

TABLE 5
Reducers with standard input shaft ①
Low speed shaft torque rating (1000 lb-in) ②
(Horizontal mounting)

Reduction	Nominal Ratio	Approx. Output RPM	Motor Horsepower & Frame Size									
			1 HP 143T	1.5 HP 145T	2 HP 145T	3 HP 182T	5 HP 184T	7.5 HP 213T	10 HP 215T	15 HP 254T	20 HP 256T	25 HP 284T
Single	3.53	496	MERC 4	MERC 4	MERC 4	MERC 4	MERC 4	MERC 4	MERC 4	MERC 4	MERC 4	MARS 8
	4.39	399	MERC 4	MERC 4	MERC 4	MERC 4	MERC 4	MERC 4	MERC 4	MERC 4	MARS 7	MARS 7
	6.12	286	MERC 3	MERC 3	MERC 3	MERC 3	MERC 3	MERC 3	MERC 3	MARS 7	MARS 7	VENS 17
Double	9.30	188	MARS 10	MARS 10	MARS 10	MARS 10	MARS 10	MARS 10	MARS 10	MARS 10	MARS 10	ATLS 26
	11.02	159	MERC 5	MERC 5	MERC 5	MERC 5	MERC 5	MERC 5	MERC 5	MARS 10	MARS 10	VENS 21
	13.85	126	MERC 6	MERC 6	MERC 6	MERC 6	MERC 6	MERC 6	MARS 12	MARS 12	VENS 22	VENS 22
	17.21	102	MERC 6	MERC 6	MERC 6	MERC 6	MERC 6	MARS 13	MARS 13	MARS 13	VENS 21	VENS 21
	20.41	86	MERC 6	MERC 6	MERC 6	MERC 6	MERC 6	MARS 12	MARS 12	VENS 23	VENS 23	VENS 23
	24.00	73	MERC 7	MERC 7	MERC 7	MERC 7	MERC 7	MARS 14	MARS 14	VENS 22	ATLS 38	ATLS 38
	31.63	55	MERC 6	MERC 6	MERC 6	MERC 6	MARS 13	MARS 13	VENS 19	ATLS 32	ATLS 32	ERTH 56
Triple	36.56	48	MERC 7	MERC 7	MERC 7	MERC 7	MARS 15	MARS 15	VENS 23	ATLS 41	ATLS 41	LUNA 51
	43.78	40	MERC 5d	MERC 5d	MERC 5d	MERC 7	MARS 16	MARS 16	VENS 24	ATLS 41	LUNA 51	ERTH 72
	54.45	32	MERC 8	MERC 8	MERC 8	MERC 8	MARS 17	VENS 24	ATLS 42	ATLS 42	ERTH 72	ERTH 72
	64.42	27	MERC 8	MERC 8	MERC 8	MARS 17	MARS 17	VENS 24	ATLS 42	LUNA 51	ERTH 72	PLRS 120
	69.63	25	MERC 7	MERC 7	MERC 7	MARS 17	MARS 17	ATLS 39	ATLS 39	LUNA 49	ERTH 68	PLRS 105
	80.01	22	MERC 8	MERC 8	MERC 8	MARS 17	VENS 24	ATLS 42	ATLS 42	ERTH 74	ERTH 74	PLRS 120
	91.41	19.1	MERC 8	MERC 8	MARS 17	MARS 17	ATLS 38	ATLS 38	ATLS 38	NEP+ 211	NEP+ 211	NEP+ 211
	99.38	17.6	MERC 7	MARS 15	MARS 15	MARS 15	VENS 23	ATLS 40	LUNA 49	ERTH 70	PLRS 105	DELT 143
	111.5	15.7	MERC 8	MERC 8	MARS 17	MARS 17	ATLS 42	ATLS 42	ERTH 74	PLRS 120	PLRS 120	NEP+ 223
	121.4	14.4	MERC 7q	MARS 17q	MARS 17q	MARS 17q	ATLS 38q	LUNA 51q	ERTH 74q	PLRS 120q	PLRS 120q	DELT 153q
138.5	12.6	MERC 7	MARS 15	MARS 15	VENS 23	ATLS 39	LUNA 49	ERTH 70	PLRS 110	DELT 144	NEP+ 210	
159.8	11.0	MERC 8	MARS 17	MARS 17	VENS 24q	ATLS 43q	ERTH 74q	ERTH 74q	PLRS 120q	DELT 154q	NEP+ 224q	
193.1	9.1	MARS 15	MARS 15	VENS 20	ATLS 33	ERTH 60	ERTH 76q	PLRS 120q	DELT 154q	NEP+ 226q	NEP+ 226q	
Quadruple	206.2	8.5	MARS 17	MARS 17	VENS 24	ATLS 43	LUNA 51	PLRS 120	PLRS 120	DELT 154	NEP+ 226	ORN+ 316
	238.2	7.3	MARS 17	MARS 17	VENS 24	ATLS 43	ERTH 76	PLRS 120	PLRS 120	NEP+ 227	NEP+ 227	ORN+ 316
	265.4	6.6	MARS 17	VENS 24	VENS 24	ATLS 43	ERTH 76	PLRS 120	PLRS 120	NEP+ 227	NEP+ 227	ORN+ 316
	295.7	5.9	MARS 17	VENS 24	ATLS 43	ATLS 43	ERTH 72	PLRS 115	DELT 147	NEP+ 213	ORN+ 316	SAT+ 420
	330.1	5.3	MARS 18	VENS 23	ATLS 40	LUNA 50	ERTH 76	PLRS 120	DELT 154	NEP+ 228	ORN+ 316	SAT+ 440
	369.8	4.7	MARS 18	ATLS 43	ATLS 43	LUNA 51	PLRS 120	DELT 140	NEP+ 229	ORN+ 274	SAT+ 440	SAT+ 440
	412.1	4.2	VENS 24	ATLS 43	ATLS 43	ERTH 72	PLRS 115	DELT 148	NEP+ 215	ORN+ 316	SAT+ 430	TTN+ 580
	459.0	3.8	VENS 23	ATLS 40	LUNA 50	ERTH 76	PLRS 120	DELT 154	NEP+ 230	ORN+ 316	SAT+ 440	TTN+ 626
	532.5	3.3	VENS 24	ATLS 43	LUNA 51	PLRS 115	DELT 149	NEP+ 217	NEP+ 217	SAT+ 430	TTN+ 587	JPT+ 874
	617.9	2.8	ATLS 40	LUNA 51	ERTH 76	PLRS 120	NEP+ 232	NEP+ 232	SAT+ 440	SAT+ 440	JPT+ 761	JPT+ 761
660.6	2.6	ERTH 76qu	ERTH 76qu	ERTH 76qu	PLRS 120qu	DELT 154qu	NEP+ 232qu	SAT+ 440qu	SAT+ 440qu	TTN+ 632qu	JPT+ 763	
741.2	2.4	ATLS 43	ERTH 72	ERTH 72	DELT 150	NEP+ 219	ORN+ 316	SAT+ 430	SAT+ 430	TTN+ 594		
900.3	1.9	ATLS 40	ERTH 76qu	PLRS 115qu	DELT 150qu	NEP+ 234qu	ORN+ 316qu	SAT+ 440qu	TTN+ 638qu	JPT+ 892qu		
1057.0	1.7	ERTH 60	PLRS 120qu	PLRS 120qu	DELT 154qu	ORN+ 316qu	SAT+ 440qu	TTN+ 640qu	JPT+ 899qu			
Quintuple	1255.0	1.4	ERTH 76	PLRS 115	PLRS 115	NEP+ 236	ORN+ 274	SAT+ 440	TTN+ 643	JPT+ 903		
	1785.0	1.0	PLRS 115	DELT 152	NEP+ 238	NEP+ 238	SAT+ 440	JPT+ 905	JPT+ 905			

Shaded areas that are **bold** require an electric fan.
 Shaded areas that are **bold and italicized** require an alternate lubricant to achieve selection, contact factory for lubrication specification.
 Shaded areas require a cooling option.

① Selections are based on 1750 RPM, NEMA B, T-Frame motors. If other motor types, speeds or HP's > 250 are required, refer application to factory. Additional ratios are available as standard items. Contact Rexnord for application details.

② Example: "VENS 19" requires a Venus size reducer rated for 19,000 lb-in torque.

d = double reduction t = triple reduction q = quadruple reduction qu = quintuple reduction

1750 RPM - Class II - Service Factor = 1.40

TABLE 5 CONTINUED

Reducers with standard input shaft ①
 Low speed shaft torque rating (1000 lb-in) ②
 (Horizontal mounting)

Reduction	Nominal Ratio	Approx. Output RPM	Motor Horsepower & Frame Size										
			30 HP 286T	40 HP 324T	50 HP 326T	60 HP 364T	75 HP 365T	100 HP 405T	125 HP 444T	150 HP 445T	200 HP	250 HP	
Single	3.53	496	MARS 8	VENS 16	VENS 16	VENS 16	<i>VENS 16</i>	<i>ERTH 42</i>	<i>NEPT 75</i>				
	4.39	399	MARS 7	VENS 16	VENS 16	VENS 16	VENS 16	<i>ATLS 28</i>	<i>ERTH 44</i>	<i>PLRS 52</i>	<i>NEPT 80</i>		
	6.12	286	VENS 17	VENS 17	VENS 17	VENS 17	<i>ATLS 30</i>	<i>ATLS 30</i>	ERTH 46	NEPT 85	NEPT 85	<i>NEPT 85</i>	
Double	9.30	188	ATLS 26	ATLS 26	ATLS 26	<i>ERTH 50</i>	<i>ERTH 50</i>	<i>ERTH 50</i>	<i>PLRS 64</i>	<i>NEPT 110</i>	<i>NEPT 110</i>		
	11.02	159	VENS 21	ATLS 36	ATLS 36	ATLS 36	<i>ERTH 60</i>	<i>ERTH 60</i>	<i>PLRS 80</i>	NEPT 110	ORN+ 241		
	13.85	126	VENS 22	ATLS 38	ATLS 38	LUNA 50	LUNA 50	PLRS 80	<i>PLRS 80</i>	NEPT 115	NEP+ 196	SAT+ 260	
	17.21	102	ATLS 38	ATLS 38	LUNA 47	ERTH 64	ERTH 64	PLRS 85	DELT 138	NEP+ 199	NEP+ 199	ORN+ 287	
	20.41	86	ATLS 38	ATLS 38	ERTH 70	ERTH 70	ERTH 70	PLRS 100	DELT 121	NEP+ 214	NEP+ 214	SAT+ 280	
	24.00	73	ATLS 38	LUNA 48	ERTH 66	PLRS 90	PLRS 90	DELT 139	NEP+ 201	NEP+ 201	ORN+ 299	ORN+ 299	
	31.63	55	ERTH 56	ERTH 66t	PLRS 80t	NEP+ 162	NEP+ 162	NEP+ 162	SAT+ 360t	SAT+ 360t	TTN+ 512	TTN+ 512	
	36.56	48	ERTH 70	ERTH 70	PLRS 110	PLRS 110	DELT 150	NEP+ 151	ORN+ 274	SAT+ 360	SAT+ 360	<i>SAT+ 360</i>	
	43.78	40	ERTH 72	PLRS 115	PLRS 115	DELT 150	NEP+ 184	ORN+ 311	ORN+ 311	SAT+ 380	SAT+ 380		
	54.45	32	PLRS 120	PLRS 120	DELT 151	NEP+ 219	NEP+ 219	ORN+ 313	SAT+ 400	SAT+ 400	TTN+ 593		
Triple	64.42	27	PLRS 120	PLRS 120	NEP+ 184	NEP+ 184	ORN+ 274	SAT+ 420	SAT+ 420	TTN+ 594	TTN+ 594	<i>JPT+ 807</i>	
	69.63	25	PLRS 105	DELT 142	NEP+ 206	NEP+ 206	ORN+ 315	SAT+ 400	TTN+ 543	TTN+ 543	<i>JPT+ 811</i>		
	80.01	22	PLRS 120	DELT 152	NEP+ 221	NEP+ 221	ORN+ 315	SAT+ 430	TTN+ 598	TTN+ 598			
	91.41	19.1	NEP+ 211	NEP+ 211	NEP+ 211	ORN+ 260	SAT+ 450	SAT+ 450	TTN+ 599	TTN+ 599			
	99.38	17.6	DELT 143	NEP+ 208	ORN+ 316	ORN+ 316	SAT+ 420	TTN+ 550	JPT+ 819	JPT+ 819			
	111.5	15.7	NEP+ 223	NEP+ 223	SAT+ 440	SAT+ 440	SAT+ 440	TTN+ 536	JPT+ 712				
	121.4	14.4	NEP+ 223q	NEP+ 223q	SAT+ 440q	SAT+ 440q	SAT+ 440q	TTN+ 605q	JPT+ 825	JPT+ 825			
	138.5	12.6	NEP+ 210	ORN+ 315	SAT+ 420	SAT+ 420	TTN+ 557						
	159.8	11.0	NEP+ 224q	ORN+ 316q	SAT+ 440q	SAT+ 440q	TTN+ 608q						
	193.1	9.1	ORN+ 316q	SAT+ 440q	SAT+ 440q	TTN+ 611q							
Quadruple	206.2	8.5	SAT+ 440	TTN+ 613	TTN+ 613	TTN+ 613	JPT+ 730						
	238.2	7.3	ORN+ 316	SAT+ 440	TTN+ 615	JPT+ 849	JPT+ 849						
	265.4	6.6	SAT+ 440	TTN+ 617	TTN+ 617	JPT+ 852							
	295.7	5.9	SAT+ 420	TTN+ 573	JPT+ 856	JPT+ 856							
	330.1	5.3	TTN+ 620	JPT+ 863	JPT+ 858								
	369.8	4.7	TTN+ 622	JPT+ 863	JPT+ 863								
	412.1	4.2	TTN+ 580	JPT+ 865									
	459.0	3.8	TTN+ 626	JPT+ 869									
	532.5	3.3	JPT+ 874										
	617.9	2.8											
660.6	2.6												
741.2	2.4												
900.3	1.9												
1057.0	1.7												
Quintuple	1255.0	1.4											
	1785.0	1.0											

Shaded areas that are **bold** require an electric fan.

Shaded areas that are **bold and italicized** require an alternate lubricant to achieve selection, contact factory for lubrication specification.

Shaded areas require a cooling option.

① Selections are based on 1750 RPM, NEMA B, T-Frame motors. If other motor types, speeds or HP's > 250 are required, refer application to factory. Additional ratios are available as standard items. Contact Rexnord for application details.

② **Example: "VENS 19" requires a Venus size reducer rated for 19,000 lb-in torque.**

d = double reduction t = triple reduction q = quadruple reduction qu = quintuple reduction

1750 RPM - Service Factor = 1.50

TABLE 6
Reducers with standard input shaft ①
Low speed shaft torque rating (1000 lb-in) ②
(Horizontal mounting)

Reduction	Nominal Ratio	Approx. Output RPM	Motor Horsepower & Frame Size									
			1 HP 143T	1.5 HP 145T	2 HP 145T	3 HP 182T	5 HP 184T	7.5 HP 213T	10 HP 215T	15 HP 254T	20 HP 256T	25 HP 284T
Single	3.53	496	MERC 4	MERC 4	MERC 4	MERC 4	MERC 4	MERC 4	MERC 4	MERC 4	MERC 4	MARS 8
	4.39	399	MERC 4	MERC 4	MERC 4	MERC 4	MERC 4	MERC 4	MERC 4	MERC 4	MARS 7	MARS 7
	6.12	286	MERC 3	MERC 3	MERC 3	MERC 3	MERC 3	MERC 3	MARS 7	MARS 7	MARS 7	VENS 17
Double	9.30	188	MARS 10	MARS 10	MARS 10	MARS 10	MARS 10	MARS 10	MARS 10	MARS 10	MARS 10	MARS 10
	11.02	159	MERC 5	MERC 5	MERC 5	MERC 5	MERC 5	MERC 5	MARS 10	MARS 10	MARS 10	VENS 21
	13.85	126	MERC 6	MERC 6	MERC 6	MERC 6	MERC 6	MERC 6	MARS 12	MARS 12	MARS 12	VENS 21
	17.21	102	MERC 6	MERC 6	MERC 6	MERC 6	MERC 6	MERC 6	MARS 13	MARS 13	VENS 21	VENS 21
	20.41	86	MERC 6	MERC 6	MERC 6	MERC 6	MERC 6	MERC 6	MARS 12	MARS 12	VENS 23	VENS 23
	24.00	73	MERC 7	MERC 7	MERC 7	MERC 7	MERC 7	MERC 7	MARS 14	MARS 14	VENS 22	ATLS 38
	31.63	55	MERC 6	MERC 6	MERC 6	MERC 6	MARS 13	MARS 13	VENS 19	ATLS 32	LUNA 39	ATLS 38
	36.56	48	MERC 7	MERC 7	MERC 7	MERC 7	MARS 15	MARS 15	VENS 23	ATLS 41	ATLS 41	ATLS 38
	43.78	40	MERC 5d	MERC 5d	MERC 5d	MERC 7	MARS 16	MARS 16	VENS 24	ATLS 41	LUNA 51	ATLS 38
54.45	32	MERC 8	MERC 8	MERC 8	MERC 8	MARS 17	MARS 17	VENS 24	ATLS 42	LUNA 51	ATLS 38	
Triple	64.42	27	MERC 8	MERC 8	MERC 8	MARS 17	MARS 17	VENS 24	ATLS 42	LUNA 51	ERTH 72	PLRS 120
	69.63	25	MERC 7	MERC 7	MERC 7	MARS 17	MARS 17	VENS 22	ATLS 39	ERTH 68	PLRS 105	PLRS 105
	80.01	22	MERC 8	MERC 8	MARS 17	MARS 17	VENS 24	ATLS 42	ATLS 42	ERTH 74	PLRS 120	PLRS 120
	91.41	19.1	MERC 8	MERC 8	MARS 17	MARS 17	ATLS 38	ATLS 38	ERTH 54	NEP+ 211	NEP+ 211	NEP+ 211
	99.38	17.6	MERC 7	MARS 15	MARS 15	VENS 23	ATLS 40	ATLS 40	LUNA 49	PLRS 105	PLRS 105	DELT 143
	111.5	15.7	MERC 8	MARS 17	MARS 17	VENS 24	ATLS 42	ATLS 42	ERTH 74	PLRS 120	PLRS 120	NEP+ 223
	121.4	14.4	MERC 7q	MARS 17q	MARS 17q	ATLS 38q	ATLS 38q	LUNA 51q	ERTH 74q	PLRS 120q	PLRS 120q	DELT 153q
	138.5	12.6	MARS 15	MARS 15	MARS 15	VENS 23	ATLS 39	LUNA 51q	ERTH 70	PLRS 110	DELT 144	NEP+ 210
	159.8	11.0	MERC 8	MARS 17	MARS 17	ATLS 43q	ATLS 43q	ERTH 74q	ERTH 74q	PLRS 120q	DELT 154q	NEP+ 224q
	193.1	9.1	MARS 15	MARS 15	VENS 20	ATLS 33	ERTH 60	ERTH 76q	PLRS 120q	DELT 154q	NEP+ 226q	ORN+ 316q
	206.2	8.5	MARS 17	MARS 17	VENS 24	ATLS 43	ERTH 76	PLRS 120	DELT 154	DELT 154	NEP+ 226	ORN+ 274
	238.2	7.3	MARS 17	VENS 24	VENS 24	ATLS 43	ERTH 76	PLRS 120	PLRS 120	NEP+ 227	NEP+ 227	ORN+ 316
265.4	6.6	MARS 17	VENS 24	ATLS 43	ATLS 43	ERTH 76	PLRS 120	DELT 154	NEP+ 227	ORN+ 316	SAT+ 440	
Quadruple	295.7	5.9	MARS 17	VENS 24	ATLS 43	LUNA 51	ERTH 72	PLRS 115	DELT 147	NEP+ 213	ORN+ 316	SAT+ 420
	330.1	5.3	MARS 18	ATLS 40	ATLS 40	LUNA 50	PLRS 120	PLRS 120	NEP+ 228	ORN+ 316	ORN+ 316	SAT+ 440
	369.8	4.7	VENS 24	ATLS 43	ATLS 43	ERTH 76	PLRS 120	DELT 140	NEP+ 229	ORN+ 274	SAT+ 440	TTN+ 622
	412.1	4.2	VENS 24	ATLS 43	ATLS 43	ERTH 72	PLRS 115	DELT 148	NEP+ 215	ORN+ 316	SAT+ 430	TTN+ 580
	459.0	3.8	VENS 23	ATLS 40	LUNA 50	ERTH 76	PLRS 120	NEP+ 230	NEP+ 230	SAT+ 440	SAT+ 440	TTN+ 626
	532.5	3.3	ATLS 43	ATLS 43	LUNA 51	PLRS 115	DELT 149	NEP+ 217	ORN+ 316	SAT+ 430	TTN+ 587	JPT+ 874
	617.9	2.8	ATLS 40	LUNA 51	ERTH 76	PLRS 120	NEP+ 232	NEP+ 232	SAT+ 440	TTN+ 570	JPT+ 761	
	660.6	2.6	ERTH 76qu	ERTH 76qu	ERTH 76qu	PLRS 120qu	NEP+ 232qu	ORN+ 274qu	SAT+ 440qu	TTN+ 632qu	TTN+ 632qu	
	741.2	2.4	ATLS 43	ERTH 72	PLRS 115qu	DELT 150	NEP+ 219	ORN+ 316	SAT+ 430	TTN+ 594		
	900.3	1.9	LUNA 51	ERTH 76qu	PLRS 115qu	DELT 154qu	NEP+ 234qu	ORN+ 316qu	SAT+ 440qu	JPT+ 892qu	JPT+ 892qu	
1057.0	1.7	ERTH 60	PLRS 120qu	PLRS 120qu	DELT 154qu	ORN+ 316qu	SAT+ 440qu	TTN+ 640qu	JPT+ 899qu			
Quintuple	1255.0	1.4	ERTH 76	PLRS 115	DELT 154	NEP+ 236	SAT+ 440	TTN+ 643	TTN+ 643	JPT+ 903		
	1785.0	1.0	PLRS 115	DELT 152	NEP+ 238	ORN+ 316	SAT+ 440	JPT+ 905	JPT+ 905			

Shaded areas that are **bold** require an electric fan.
 Shaded areas that are **bold and italicized** require an alternate lubricant to achieve selection, contact factory for lubrication specification.
 Shaded areas require a cooling option.

① Selections are based on 1750 RPM, NEMA B, T-Frame motors. If other motor types, speeds or HP's > 250 are required, refer application to factory. Additional ratios are available as standard items. Contact Rexnord for application details.

② **Example: "VENS 19" requires a Venus size reducer rated for 19,000 lb-in torque.**

d = double reduction t = triple reduction q = quadruple reduction qu = quintuple reduction

1750 RPM - Service Factor = 1.50

TABLE 6 CONTINUED

Reducers with standard input shaft ①
 Low speed shaft torque rating (1000 lb-in) ②
 (Horizontal mounting)

Reduction	Nominal Ratio	Approx. Output RPM	Motor Horsepower & Frame Size										
			30 HP 286T	40 HP 324T	50 HP 326T	60 HP 364T	75 HP 365T	100 HP 405T	125 HP 444T	150 HP 445T	200HP	250 HP	
Single	3.53	496	MARS 8	VENS 16	VENS 16	VENS 16	VENS 16	VENS 16	ERTH 42	NEPT 75			
	4.39	399	VENS 16	VENS 16	VENS 16	VENS 16	ERTH 44	ERTH 44	ERTH 44	PLRS 52	NEPT 80		
	6.12	286	VENS 17	VENS 17	VENS 17	ATLS 30	ATLS 30	ERTH 46	ERTH 46	NEPT 85	NEPT 85	NEPT 85	
Double	9.30	188	ATLS 26	ATLS 26	ATLS 26	ERTH 50	ERTH 50	ERTH 50	PLRS 64	NEPT 110	NEPT 110		
	11.02	159	VENS 21	ATLS 36	ATLS 36	ATLS 36	ERTH 60	ERTH 60	PLRS 80	NEPT 110	ORN+ 241		
	13.85	126	VENS 22	ATLS 38	ATLS 38	LUNA 50	ERTH 60	PLRS 80	NEP+ 196	NEP+ 196	NEP+ 196	SAT+ 260	
	17.21	102	ATLS 38	ATLS 38	LUNA 47	ERTH 64	PLRS 85	DELT 138	DELT 138	NEP+ 199	NEP+ 199	ORN+ 287	
	20.41	86	ATLS 38	LUNA 41	ERTH 70	ERTH 70	PLRS 100	PLRS 100	NEP+ 214	NEP+ 214	NEP+ 214	SAT+ 429	
	24.00	73	ATLS 38	ERTH 66	ERTH 66	PLRS 90	DELT 139	DELT 139	NEP+ 201	NEP+ 201	ORN+ 299	SAT+ 350	
	31.63	55	ERTH 56	ERTH 66t	PLRS 80t	NEP+ 162	NEP+ 162	SAT+ 360t	SAT+ 360t	SAT+ 360t	TTN+ 512	TTN+ 512	
	36.56	48	ERTH 70	PLRS 110	PLRS 110	PLRS 110	DELT 150	NEP+ 151	ORN+ 274	SAT+ 360			
	43.78	40	ERTH 72	PLRS 115	PLRS 115	DELT 150	NEP+ 184	ORN+ 311	ORN+ 311	SAT+ 380			
	54.45	32	PLRS 120	PLRS 120	DELT 151	NEP+ 219	NEP+ 219	ORN+ 313	SAT+ 400	TTN+ 593	TTN+ 593		
Triple	64.42	27	PLRS 120	DELT 135	NEP+ 184	ORN+ 274	ORN+ 274	SAT+ 420	SAT+ 420	TTN+ 594	JPT+ 807		
	69.63	25	PLRS 105	DELT 142	NEP+ 206	ORN+ 315	ORN+ 315	SAT+ 400	TTN+ 543	TTN+ 543	JPT+ 811		
	80.01	22	PLRS 120	NEP+ 221	NEP+ 221	ORN+ 315	ORN+ 315	SAT+ 430	TTN+ 598	TTN+ 598			
	91.41	19.1	NEP+ 211	NEP+ 211	ORN+ 260	ORN+ 260	SAT+ 450	SAT+ 450	TTN+ 599	JPT+ 706			
	99.38	17.6	NEP+ 208	NEP+ 208	ORN+ 316	ORN+ 316	SAT+ 420	TTN+ 550	JPT+ 819	JPT+ 819			
	111.5	15.7	NEP+ 223	NEP+ 223	SAT+ 440	SAT+ 440	SAT+ 440	JPT+ 712	JPT+ 712				
	121.4	14.4	NEP+ 223q	ORN+ 274q	SAT+ 440q	SAT+ 440q	TTN+ 605q	TTN+ 605q	JPT+ 825				
	138.5	12.6	NEP+ 210	ORN+ 315	SAT+ 420	SAT+ 420	TTN+ 557						
	159.8	11.0	NEP+ 224q	ORN+ 316q	SAT+ 440q	TTN+ 608q	TTN+ 608q						
	193.1	9.1	ORN+ 316q	SAT+ 440q	TTN+ 611q	TTN+ 611q							
Quadruple	206.2	8.5	SAT+ 440	TTN+ 613	TTN+ 613	JPT+ 730							
	238.2	7.3	SAT+ 440	TTN+ 615	TTN+ 615	JPT+ 849							
	265.4	6.6	SAT+ 440	TTN+ 617	JPT+ 852	JPT+ 852							
	295.7	5.9	SAT+ 420	TTN+ 573	JPT+ 856	JPT+ 858							
	330.1	5.3	TTN+ 620	JPT+ 858	JPT+ 858								
	369.8	4.7	TTN+ 622	JPT+ 863									
	412.1	4.2	JPT+ 865	JPT+ 865									
	459.0	3.8	JPT+ 869										
	532.5	3.3	JPT+ 874										
	617.9	2.8											
660.6	2.6												
741.2	2.4												
900.3	1.9												
1057.0	1.7												
Quintuple	1255.0	1.4											
	1785.0	1.0											

Shaded areas that are **bold** require an electric fan.
 Shaded areas that are **bold and italicized** require an alternate lubricant to achieve selection, contact factory for lubrication specification.
 Shaded areas require a cooling option.

① Selections are based on 1750 RPM, NEMA B, T-Frame motors. If other motor types, speeds or HP's > 250 are required, refer application to factory. Additional ratios are available as standard items. Contact Rexnord for application details.

② Example: "VENS 19" requires a Venus size reducer rated for 19,000 lb-in torque.

d = double reduction t = triple reduction q = quadruple reduction qu = quintuple reduction

1750 RPM - Service Factor = 1.75

TABLE 7

Reducers with standard input shaft ①
 Low speed shaft torque rating (1000 lb-in) ②
 (Horizontal mounting)

Reduction	Nominal Ratio	Approx. Output RPM	Motor Horsepower & Frame Size										
			1 HP 143T	1.5 HP 145T	2 HP 145T	3 HP 182T	5 HP 184T	7.5 HP 213T	10 HP 215T	15 HP 254T	20 HP 256T	25 HP 284T	
Single	3.53	496	MERC 4	MERC 4	MERC 4	MERC 4	MERC 4	MERC 4	MERC 4	MERC 4	MERC 4	MARS 8	MARS 8
	4.39	399	MERC 4	MERC 4	MERC 4	MERC 4	MERC 4	MERC 4	MERC 4	MERC 4	MARS 7	MARS 7	VENS 16
	6.12	286	MERC 3	MERC 3	MERC 3	MERC 3	MERC 3	MERC 3	MERC 3	MARS 7	MARS 7	VENS 17	VENS 17
Double	9.30	188	MARS 10	MARS 10	MARS 10	MARS 10	MARS 10	MARS 10	MARS 10	MARS 10	MARS 10	ATLS 26	ATLS 26
	11.02	159	MERC 5	MERC 5	MERC 5	MERC 5	MERC 5	MERC 5	MERC 5	MARS 10	MARS 10	VENS 21	VENS 21
	13.85	126	MERC 6	MERC 6	MERC 6	MERC 6	MERC 6	MERC 6	MARS 12	MARS 12	VENS 22	VENS 22	VENS 22
	17.21	102	MERC 6	MERC 6	MERC 6	MERC 6	MERC 6	MERC 6	MARS 13	MARS 13	VENS 21	VENS 21	ATLS 38
	20.41	86	MERC 6	MERC 6	MERC 6	MERC 6	MERC 6	MARS 12	MARS 12	VENS 23	VENS 23	VENS 23	ATLS 38
	24.00	73	MERC 7	MERC 7	MERC 7	MERC 7	MERC 7	MARS 14	MARS 14	VENS 22	VENS 22	ATLS 38	ATLS 38
	31.63	55	MERC 6	MERC 6	MERC 6	MERC 6	MARS 13	VENS 19	VENS 19	ATLS 32	ERTH 56	ERTH 56	ERTH 56
Triple	36.56	48	MERC 7	MERC 7	MERC 7	MERC 7	MARS 15	VENS 23	VENS 23	ATLS 41	ATLS 41	LUNA 51	ERTH 70
	43.78	40	MERC 5d	MERC 5d	MERC 7	MARS 10d	MARS 16	VENS 24	ATLS 41	ATLS 41	ERTH 72	ERTH 72	ERTH 72
	54.45	32	MERC 8	MERC 8	MERC 8	MARS 17	MARS 17	ATLS 42	ATLS 42	LUNA 51	ERTH 72	PLRS 120	PLRS 120
	64.42	27	MERC 8	MERC 8	MERC 8	MARS 17	VENS 24	ATLS 42	ATLS 42	ERTH 72	PLRS 120	PLRS 120	PLRS 120
	69.63	25	MERC 7	MERC 7	MARS 17	MARS 17	VENS 22	ATLS 39	LUNA 49	ERTH 68	PLRS 105	PLRS 105	PLRS 105
	80.01	22	MERC 8	MERC 8	MARS 17	MARS 17	VENS 24	ATLS 42	LUNA 51	ERTH 74	PLRS 120	PLRS 120	PLRS 120
	91.41	19.1	MERC 8	MARS 17	MARS 17	MARS 17	ATLS 38	ERTH 54	NEP+ 211	NEP+ 211	NEP+ 211	NEP+ 211	NEP+ 211
	99.38	17.6	MERC 7	MARS 15	MARS 15	VENS 23	ATLS 40	LUNA 49	ERTH 70	PLRS 105	DELT 143	DELT 143	DELT 143
	111.5	15.7	MERC 8	MARS 17	MARS 17	VENS 24	ATLS 42	ERTH 74	ERTH 74	PLRS 120	NEP+ 223	NEP+ 223	NEP+ 223
	121.4	14.4	MERC 7q	MARS 17q	MARS 17q	ATLS 38q	ATLS 38q	LUNA 51q	ERTH 74q	PLRS 120q	DELT 153q	NEP+ 223q	NEP+ 223q
	138.5	12.6	MARS 15	MARS 15	VENS 23	VENS 24q	ATLS 43q	ERTH 70	PLRS 110	DELT 144	NEP+ 210	NEP+ 210	NEP+ 210
159.8	11.0	MARS 17	MARS 17	VENS 24q	ATLS 43q	LUNA 51q	ERTH 74q	PLRS 120q	DELT 154q	NEP+ 224q	NEP+ 224q	NEP+ 224q	
Quadruple	193.1	9.1	MARS 15	VENS 20	ATLS 33	LUNA 40	ERTH 60	PLRS 120q	PLRS 120q	NEP+ 172	NEP+ 226q	ORN+ 316q	ORN+ 316q
	206.2	8.5	MARS 17	MARS 17	ATLS 43	ATLS 43	PLRS 120	DELT 154	DELT 154	NEP+ 226	ORN+ 274	SAT+ 440	SAT+ 440
	238.2	7.3	MARS 17	VENS 24	ATLS 43	ATLS 43	ERTH 76	PLRS 120	DELT 154	NEP+ 227	ORN+ 316	SAT+ 440	SAT+ 440
	265.4	6.6	MARS 17	VENS 24	ATLS 43	LUNA 51	ERTH 76	PLRS 120	DELT 154	NEP+ 227	ORN+ 316	SAT+ 440	SAT+ 440
	295.7	5.9	VENS 24	ATLS 43	ATLS 43	LUNA 51	PLRS 115	DELT 147	NEP+ 213	ORN+ 316	SAT+ 420	SAT+ 420	SAT+ 420
	330.1	5.3	VENS 23	ATLS 40	ATLS 40	ERTH 76	PLRS 120	DELT 154	NEP+ 228	ORN+ 316	SAT+ 440	TTN+ 620	TTN+ 620
	369.8	4.7	VENS 24	ATLS 43	ATLS 43	ERTH 76	PLRS 120	NEP+ 229	NEP+ 229	SAT+ 440	SAT+ 440	TTN+ 622	TTN+ 622
	412.1	4.2	VENS 24	ATLS 43	LUNA 51	ERTH 72	PLRS 115	NEP+ 215	ORN+ 316	SAT+ 430	TTN+ 580	TTN+ 580	TTN+ 580
	459.0	3.8	ATLS 40	ATLS 40	ERTH 76	PLRS 120	DELT 154	NEP+ 230	ORN+ 316	SAT+ 440	TTN+ 626	JPT+ 869	JPT+ 869
	532.5	3.3	ATLS 43	LUNA 51	ERTH 72	PLRS 115	NEP+ 217	ORN+ 316	SAT+ 430	TTN+ 587	JPT+ 874	JPT+ 874	JPT+ 874
	617.9	2.8	ATLS 40	ERTH 76	ERTH 76	PLRS 120	NEP+ 232	SAT+ 440	SAT+ 440	TTN+ 570	JPT+ 761	JPT+ 761	JPT+ 761
	660.6	2.6	ERTH 76qu	ERTH 76qu	PLRS 120qu	PLRS 120qu	NEP+ 232qu	SAT+ 440qu	SAT+ 440qu	TTN+ 632qu	JPT+ 763	JPT+ 763	JPT+ 763
	741.2	2.4	ATLS 43	ERTH 72	DELT 150	DELT 150	ORN+ 316	SAT+ 430	SAT+ 430	TTN+ 594	JPT+ 763	JPT+ 763	JPT+ 763
900.3	1.9	LUNA 51	ERTH 76qu	PLRS 115qu	DELT 154qu	ORN+ 316qu	SAT+ 440qu	TTN+ 638qu	JPT+ 892qu	JPT+ 892qu	JPT+ 892qu	JPT+ 892qu	
1057.0	1.7	PLRS 120qu	PLRS 120qu	PLRS 120qu	ORN+ 316qu	ORN+ 316qu	SAT+ 440qu	TTN+ 640qu	JPT+ 899qu	JPT+ 899qu	JPT+ 899qu	JPT+ 899qu	
Qunituple	1255.0	1.4	ERTH 76	PLRS 115	DELT 154	NEP+ 236	SAT+ 440	TTN+ 643	JPT+ 903	JPT+ 903	JPT+ 903	JPT+ 903	JPT+ 903
	1785.0	1.0	PLRS 115	DELT 149	NEP+ 238	ORN+ 316	TTN+ 591	JPT+ 905	JPT+ 905	JPT+ 905	JPT+ 905	JPT+ 905	JPT+ 905

Shaded areas that are **bold** require an electric fan.
 Shaded areas that are **bold and italicized** require an alternate lubricant to achieve selection, contact factory for lubrication specification.
 Shaded areas require a cooling option.

① Selections are based on 1750 RPM, NEMA B, T-Frame motors. If other motor types, speeds or HP's > 250 are required, refer application to factory. Additional ratios are available as standard items. Contact Rexnord for application details.

② Example: "VENS 19" requires a Venus size reducer rated for 19,000 lb-in torque.

d = double reduction t = triple reduction q = quadruple reduction qu = quintuple reduction

1750 RPM - Service Factor = 1.75

TABLE 7 CONTINUED

Reducers with standard input shaft ①
 Low speed shaft torque rating (1000 lb-in) ②
 (Horizontal mounting)

Reduction	Nominal Ratio	Approx. Output RPM	Motor Horsepower & Frame Size										
			30 HP 286T	40 HP 324T	50 HP 326T	60 HP 364T	75 HP 365T	100 HP 405T	125 HP 444T	150 HP 445T	200 HP	250 HP	
Single	3.53	496	MARS 8	VENS 16	VENS 16	VENS 16	VENS 16	VENS 16	ERTH 42	NEPT 75			
	4.39	399	VENS 16	VENS 16	VENS 16	VENS 16	ATLS 28	ATLS 28	ERTH 44	PLRS 52	NEPT 80		
	6.12	286	VENS 17	VENS 17	ATLS 30	ATLS 30	ATLS 30	ERTH 46	ERTH 46	NEPT 85	NEPT 85	JUP+ 150	
Double	9.30	188	ATLS 26	ATLS 26	ERTH 50	ERTH 50	ERTH 50	PLRS 64	NEPT 110	NEPT 110			
	11.02	159	VENS 21	ATLS 36	ATLS 36	LUNA 50	PLRS 80	PLRS 80	NEPT 110	NEPT 110	ORN+ 241		
	13.85	126	ATLS 38	ATLS 38	LUNA 50	LUNA 50	ERTH 64	PLRS 85	NEPT 115	NEP+ 209	NEP+ 209	SAT+ 260	
	17.21	102	ATLS 38	LUNA 47	ERTH 64	ERTH 64	PLRS 85	DELT 138	DELT 138	NEP+ 199	ORN+ 287	ORN+ 287	
	20.41	86	ATLS 38	ERTH 70	ERTH 70	ERTH 70	PLRS 100	DELT 121	NEP+ 214	NEP+ 214	ORN+ 241	TTN+ 477	
	24.00	73	LUNA 48	ERTH 66	PLRS 90	PLRS 90	DELT 139	NEP+ 201	NEP+ 201	ORN+ 299	ORN+ 299	TTN+ 496	
Triple	31.63	55	ERTH 66t	PLRS 80t	NEP+ 162	NEP+ 162	NEP+ 162	SAT+ 360t	SAT+ 360t	SAT+ 360t	TTN+ 512t	TTN+ 512	
	36.56	48	ERTH 70	PLRS 110	PLRS 110	DELT 150	NEP+ 184	ORN+ 274	ORN+ 274	SAT+ 360			
	43.78	40	PLRS 115	PLRS 115	DELT 150	NEP+ 184	ORN+ 311	ORN+ 311	SAT+ 380	TTN+ 589			
	54.45	32	PLRS 120	DELT 151	NEP+ 219	NEP+ 219	ORN+ 313	SAT+ 400	TTN+ 593	TTN+ 593	JPT+ 800		
	64.42	27	PLRS 120	NEP+ 184	ORN+ 274	ORN+ 274	SAT+ 420	SAT+ 420	TTN+ 594	TTN+ 594	JPT+ 807		
	69.63	25	DELT 142	NEP+ 206	NEP+ 206	ORN+ 315	ORN+ 315	TTN+ 543	TTN+ 543	JPT+ 811			
	80.01	22	DELT 152	NEP+ 221	ORN+ 315	ORN+ 315	SAT+ 430	TTN+ 598	TTN+ 598	JPT+ 703			
	91.41	19.1	NEP+ 211	NEP+ 211	ORN+ 260	SAT+ 450	SAT+ 450	TTN+ 599	JPT+ 706				
	99.38	17.6	NEP+ 208	ORN+ 316	ORN+ 316	SAT+ 420	TTN+ 550	JPT+ 819	JPT+ 819	JPT+ 819			
	111.5	15.7	NEP+ 223	SAT+ 440	SAT+ 440	SAT+ 440	TTN+ 536	JPT+ 712					
Quadruple	121.4	14.4	NEP+ 223q	SAT+ 440q	SAT+ 440q	SAT+ 440q	TTN+ 605q	JPT+ 210					
	138.5	12.6	ORN+ 315	SAT+ 420	SAT+ 420	TTN+ 557							
	159.8	11.0	ORN+ 316q	SAT+ 440q	SAT+ 440q	TTN+ 608q	JPT+ 724q						
	193.1	9.1	SAT+ 440q	SAT+ 440q	TTN+ 613								
	206.2	8.5	TTN+ 440	TTN+ 440	TTN+ 613	JPT+ 730							
	238.2	7.3	SAT+ 440	TTN+ 615	JPT+ 849	JPT+ 849							
	265.4	6.6	TTN+ 617	TTN+ 617	JPT+ 852								
	295.7	5.9	TTN+ 573	JPT+ 856									
	330.1	5.3	TTN+ 620	JPT+ 858									
	369.8	4.7	TTN+ 622	JPT+ 863									
	412.1	4.2	JPT+ 865										
	459.0	3.8	JPT+ 869										
	532.5	3.3											
617.9	2.8												
660.6	2.6												
741.2	2.4												
900.3	1.9												
1057.0	1.7												
Quintuple	1255.0	1.4											
	1785.0	1.0											

Shaded areas that are **bold** require an electric fan.

Shaded areas that are **bold and italicized** require an alternate lubricant to achieve selection, contact factory for lubrication specification.

Shaded areas require a cooling option.

① Selections are based on 1750 RPM, NEMA B, T-Frame motors. If other motor types, speeds or HP's > 250 are required, refer application to factory. Additional ratios are available as standard items. Contact Rexnord for application details.

② **Example: "VENS 19" requires a Venus size reducer rated for 19,000 lb-in torque.**

d = double reduction t = triple reduction q = quadruple reduction qu = quintuple reduction

1750 RPM - Class III - Service Factor = 2.00

TABLE 8

Reducers with standard input shaft ①
 Low speed shaft torque rating (1000 lb-in) ②
 (Horizontal mounting)

Reduction	Nominal Ratio	Approx. Output RPM	Motor Horsepower & Frame Size										
			1 HP 143T	1.5 HP 145T	2 HP 145T	3 HP 182T	5 HP 184T	7.5 HP 213T	10 HP 215T	15 HP 254T	20 HP 256T	25 HP 284T	
Single	3.53	496	MERC 4	MERC 4	MERC 4	MERC 4	MERC 4	MERC 4	MERC 4	MERC 4	MERC 4	MARS 8	MARS 8
	4.39	399	MERC 4	MERC 4	MERC 4	MERC 4	MERC 4	MERC 4	MERC 4	MERC 4	MARS 7	MARS 7	VENS 16
	6.12	286	MERC 3	MERC 3	MERC 3	MERC 3	MERC 3	MARS 7	MARS 7	MARS 7	VENS 17	VENS 17	VENS 17
Double	9.30	188	MARS 10	MARS 10	MARS 10	MARS 10	MARS 10	MARS 10	MARS 10	MARS 10	MARS 10	ATLS 26	ATLS 26
	11.02	159	MERC 5	MERC 5	MERC 5	MERC 5	MERC 5	MARS 10	MARS 10	VENS 21	VENS 21	VENS 21	VENS 21
	13.85	126	MERC 6	MERC 6	MERC 6	MERC 6	MERC 6	MARS 12	MARS 12	VENS 22	VENS 22	VENS 22	ATLS 38
	17.21	102	MERC 6	MERC 6	MERC 6	MERC 6	MERC 6	MARS 13	MARS 13	VENS 21	ATLS 38	ATLS 38	ATLS 38
	20.41	86	MERC 6	MERC 6	MERC 6	MERC 6	MARS 12	MARS 12	VENS 23	VENS 23	ATLS 38	ATLS 38	ATLS 38
	24.00	73	MERC 7	MERC 7	MERC 7	MERC 7	MARS 14	MARS 14	VENS 22	ATLS 38	ATLS 38	ATLS 38	LUNA 48
Triple	31.63	55	MERC 6	MERC 6	MERC 6	MARS 13	MARS 13	VENS 19	ATLS 32	LUNA 39	ERTH 56	ERTH 66t	ERTH 66t
	36.56	48	MERC 7	MERC 7	MERC 7	MARS 15	MARS 15	VENS 23	ATLS 41	ATLS 41	LUNA 51	ERTH 70	ERTH 70
	43.78	40	MERC 5d	MERC 5d	MERC 7	MARS 10d	MARS 16	VENS 24	ATLS 41	LUNA 51	ERTH 72	PLRS 115	PLRS 115
	54.45	32	MERC 8	MERC 8	MERC 8	MARS 17	VENS 24	ATLS 42	ATLS 42	ERTH 72	PLRS 120	PLRS 120	PLRS 120
	64.42	27	MERC 8	MERC 8	MARS 17	MARS 17	VENS 24	ATLS 42	LUNA 51	ERTH 72	PLRS 120	PLRS 120	PLRS 120
	69.63	25	MERC 7	MERC 7	MARS 17	MARS 17	ATLS 39	ATLS 39	LUNA 49	PLRS 105	PLRS 105	PLRS 105	DELTA 142
	80.01	22	MERC 8	MARS 17	MARS 17	MARS 17	ATLS 42	ATLS 42	ERTH 74	PLRS 120	PLRS 120	PLRS 120	DELTA 152
	91.41	19.1	MERC 8	MARS 17	MARS 17	ATLS 38	ATLS 38	ERTH 54	NEP+ 211	NEP+ 211	NEP+ 211	NEP+ 211	NEP+ 211
	99.38	17.6	MERC 7	MARS 15	MARS 15	VENS 23	ATLS 40	LUNA 49	ERTH 70	PLRS 105	DELTA 143	DELTA 143	NEP+ 208
	111.5	15.7	MERC 8	MARS 17	MARS 17	VENS 24	ATLS 42	ERTH 74	ERTH 74	PLRS 120	NEP+ 223	NEP+ 223	NEP+ 223
	121.4	14.4	MARS 17q	MARS 17q	MARS 17q	VENS 24q	LUNA 51q	ERTH 74q	PLRS 120q	PLRS 120q	NEP+ 223q	NEP+ 223q	NEP+ 223q
	138.5	12.6	MARS 15	MARS 15	VENS 23	ATLS 39	LUNA 49	ERTH 70	PLRS 110	DELTA 144	NEP+ 210	NEP+ 210	ORN+ 315
159.8	11.0	MARS 17	MARS 17	VENS 24q	ATLS 43q	ERTH 74q	ERTH 74q	PLRS 120q	DELTA 154q	NEP+ 224q	NEP+ 224q	ORN+ 316q	
Quadruple	193.1	9.1	MARS 15	VENS 20	ATLS 33	LUNA 40	ERTH 76q	ERTH 76q	DELTA 154	NEP+ 226q	ORN+ 316q	SAT+ 440q	SAT+ 440q
	206.2	8.5	MARS 17	VENS 24	ATLS 43	ATLS 43	ERTH 76	PLRS 120	DELTA 154	NEP+ 226	ORN+ 274	TTN+ 613	TTN+ 613
	238.2	7.3	MARS 17	VENS 24	ATLS 43	LUNA 51	ERTH 76	PLRS 120	DELTA 154	NEP+ 227	ORN+ 316	SAT+ 440	SAT+ 440
	265.4	6.6	MARS 17	ATLS 43	ATLS 43	LUNA 51	PLRS 120	DELTA 154	NEP+ 227	ORN+ 316	SAT+ 440	SAT+ 440	SAT+ 440
	295.7	5.9	VENS 24	ATLS 43	ATLS 43	ERTH 72	PLRS 115	DELTA 147	NEP+ 213	ORN+ 316	SAT+ 420	TTN+ 573	TTN+ 573
	330.1	5.3	VENS 23	ATLS 40	LUNA 50	ERTH 76	PLRS 120	NEP+ 228	NEP+ 228	ORN+ 316	SAT+ 440	TTN+ 620	TTN+ 620
	369.8	4.7	VENS 24	ATLS 43	LUNA 51	ERTH 76	PLRS 120	NEP+ 229	NEP+ 229	ORN+ 316	SAT+ 440	TTN+ 622	TTN+ 622
	412.1	4.2	ATLS 43	ATLS 43	ERTH 72	PLRS 115	DELTA 148	NEP+ 215	ORN+ 316	SAT+ 430	TTN+ 580	JPT+ 865	JPT+ 865
	459.0	3.8	ATLS 40	LUNA 50	ERTH 76	PLRS 120	DELTA 154	NEP+ 230	ORN+ 316	SAT+ 440	TTN+ 626	JPT+ 869	JPT+ 869
	532.5	3.3	ATLS 43	LUNA 51	PLRS 115	PLRS 115	NEP+ 217	ORN+ 316	SAT+ 430	SAT+ 430	JPT+ 874	JPT+ 874	JPT+ 874
	617.9	2.8	LUNA 51	ERTH 76	PLRS 120	DELTA 133	NEP+ 232	SAT+ 440	SAT+ 440	JPT+ 761			
	660.6	2.6	ERTH 76qu	ERTH 76qu	PLRS 120qu	DELTA 154qu	NEP+ 232qu	SAT+ 440qu	SAT+ 440qu	TTN+ 632qu			
741.2	2.4	ERTH 72	PLRS 115qu	DELTA 150	NEP+ 219	ORN+ 316	SAT+ 430	TTN+ 594					
Qunituple	900.3	1.9	ERTH 76qu	PLRS 115qu	DELTA 154qu	NEP+ 234qu	ORN+ 316qu	SAT+ 440qu	TTN+ 638qu	JPT+ 892qu			
	1057.0	1.7	PLRS 120qu	PLRS 120qu	DELTA 154qu	ORN+ 316qu	SAT+ 440qu	TTN+ 640qu	JPT+ 899qu				
	1255.0	1.4	ERTH 76	DELTA 154	DELTA 154	ORN+ 274	SAT+ 440	TTN+ 643	JPT+ 903				
1785.0	1.0	PLRS 115	NEP+ 238	NEP+ 238	SAT+ 440	TTN+ 591	JPT+ 905						

Shaded areas that are **bold** require an electric fan.
 Shaded areas that are **bold and italicized** require an alternate lubricant to achieve selection, contact factory for lubrication specification.
 Shaded areas require a cooling option.

① Selections are based on 1750 RPM, NEMA B, T-Frame motors. If other motor types, speeds or HP's > 250 are required, refer application to factory. Additional ratios are available as standard items. Contact Rexnord for application details.

② Example: "VENS 19" requires a Venus size reducer rated for 19,000 lb-in torque.

d = double reduction t = triple reduction q = quadruple reduction qu = quintuple reduction

1750 RPM - Class III - Service Factor = 2.00

TABLE 8 CONTINUED

Reducers with standard input shaft ①
 Low speed shaft torque rating (1000 lb-in) ②
 (Horizontal mounting)

Reduction	Nominal Ratio	Approx. Output RPM	Motor Horsepower & Frame Size									
			30 HP 286T	40 HP 324T	50 HP 326T	60 HP 364T	75 HP 365T	100 HP 405T	125 HP 444T	150 HP 445T	200 HP	250 HP
Single	3.53	496	MARS 8	VENS 16	VENS 16	VENS 16	<i>ERTH 42</i>	<i>ERTH 42</i>	<i>NEPT 75</i>			
	4.39	399	VENS 16	VENS 16	VENS 16	ATLS 28	ATLS 28	<i>ERTH 44</i>	<i>ERTH 44</i>	<i>PLRS 52</i>	<i>NEPT 80</i>	
	6.12	286	VENS 17	VENS 17	ATLS 30	ATLS 30	ERTH 46	ERTH 46	NEPT 85	NEPT 85	NEPT 85	
Double	9.30	188	ATLS 26	ATLS 26	ERTH 50	<i>ERTH 50</i>	<i>ERTH 50</i>	<i>PLRS 64</i>	<i>PLRS 64</i>	<i>NEPT 10</i>		
	11.02	159	ATLS 36	ATLS 36	LUNA 50	LUNA 50	<i>ERTH 60</i>	<i>PLRS 80</i>	NEP+ 196	NEP+ 196	ORN+ 241	
	13.85	126	ATLS 38	ATLS 38	LUNA 50	ERTH 64	PLRS 85	DELT 131	NEP+ 209	NEP+ 209	NEP+ 209	SAT+ 260
	17.21	102	ATLS 38	LUNA 47	ERTH 64	PLRS 85	DELT 138	DELT 138	NEP+ 199	NEP+ 199	ORN+ 287	SAT+ 320
	20.41	86	LUNA 41	ERTH 70	ERTH 70	PLRS 100	PLRS 100	NEP+ 214	NEP+ 214	NEP+ 214	SAT+ 280	TTN+ 477
	24.00	73	ERTH 66	ERTH 66	PLRS 90	DELT 139	DELT 139	NEP+ 201	ORN+ 299	ORN+ 299	SAT+ 350	TTN+ 496
	31.63	55	ERTH 66t	NEP+ 162	NEP+ 162	NEP+ 162	SAT+ 360t	SAT+ 360t	SAT+ 360t	SAT+ 360t	TTN+ 512t	
	36.56	48	PLRS 110	PLRS 110	DELT 150	DELT 150	NEP+ 184	ORN+ 274	SAT+ 360	TTN+ 580	TTN+ 580	
	43.78	40	PLRS 115	DELT 150	NEP+ 184	NEP+ 184	ORN+ 311	ORN+ 311	SAT+ 380	TTN+ 589	TTN+ 589	
	54.45	32	PLRS 120	DELT 151	NEP+ 219	ORN+ 313	ORN+ 313	SAT+ 400	TTN+ 593	TTN+ 593	JPT+ 800	
Triple	64.42	27	DELT 135	NEP+ 184	ORN+ 274	ORN+ 274	SAT+ 420	SAT+ 420	TTN+ 594	JPT+ 807		
	69.63	25	DELT 142	NEP+ 206	ORN+ 315	ORN+ 315	SAT+ 400	TTN+ 543	JPT+ 811	JPT+ 811		
	80.01	22	NEP+ 221	NEP+ 221	ORN+ 315	ORN+ 315	SAT+ 430	TTN+ 598	JPT+ 703			
	91.41	19.1	NEP+ 211	ORN+ 260	SAT+ 450	SAT+ 450	SAT+ 450	TTN+ 599				
	99.38	17.6	NEP+ 208	ORN+ 316	SAT+ 420	SAT+ 420	TTN+ 550	JPT+ 819	JPT+ 819			
	111.5	15.7	NEP+ 223	SAT+ 440	SAT+ 440	SAT+ 440	JPT+ 712					
	121.4	14.4	ORN+ 274q	SAT+ 440q	SAT+ 440q	TTN+ 605q	TTN+ 605q	JPT+ 825				
	138.5	12.6	ORN+ 315	SAT+ 420	TTN+ 557	TTN+ 557	JPT+ 840					
	159.8	11.0	ORN+ 316q	SAT+ 440q	TTN+ 608q	TTN+ 608q						
	193.1	9.1	SAT+ 440q	TTN+ 611q	TTN+ 611q							
Quadruple	206.2	8.5	TTN+ 440	TTN+ 440	JPT+ 730							
	238.2	7.3	TTN+ 615	TTN+ 615	JPT+ 849							
	265.4	6.6	TTN+ 617	JPT+ 852								
	295.7	5.9	TTN+ 573	JPT+ 856								
	330.1	5.3	JPT+ 858	JPT+ 858								
	369.8	4.7	JPT+ 863									
	412.1	4.2	JPT+ 865									
	459.0	3.8										
	532.5	3.3										
	617.9	2.8										
660.6	2.6											
741.2	2.4											
900.3	1.9											
1057.0	1.7											
Quintuple	1225.0	1.4										
	1785.0	1.0										

Shaded areas that are **bold** require an electric fan.
 Shaded areas that are **bold and italicized** require an alternate lubricant to achieve selection, contact factory for lubrication specification.
 Shaded areas require a cooling option.

① Selections are based on 1750 RPM, NEMA B, T-Frame motors. If other motor types, speeds or HP's > 250 are required, refer application to factory. Additional ratios are available as standard items. Contact Rexnord for application details.

② **Example: "VENS 19" requires a Venus size reducer rated for 19,000 lb-in torque.**

d = double reduction t = triple reduction q = quadruple reduction qu = quintuple reduction

1750 RPM - Class I - Service Factor = 1.00

TABLE 9

Low speed shaft torque rating (1000 lb-in) ①②
(Horizontal mounting)

Reduction	Nominal Ratio	Approx. Output RPM	Motor Horsepower & Frame Size											
			1 HP 143TC	1.5 HP 145TC	2 HP 145TC	3 HP 182TC	5 HP 184TC	7.5 HP 123TC	10 HP 215TC	15 HP 254TC	20 HP 256TC	25 HP 184TC	30 HP 286TC	
Single	3.53	496	MERC 4	MERC 4	MERC 4	MERC 4	MERC 4	MERC 4	MERC 4	MERC 4	VENS 16	VENS 16	VENS 16	VENS 16
	4.39	399	MERC 4	MERC 4	MERC 4	MERC 4	MERC 4	MERC 4	MERC 4	MERC 4	VENS 16	VENS 16	VENS 16	VENS 16
	6.12	286	MERC 3	MERC 3	MERC 3	MERC 3	MERC 3	MERC 3	MERC 3	MERC 3	VENS 17	VENS 17	VENS 17	VENS 17
Double	9.30	188	MARS 10	MARS 10	MARS 10	MARS 10	MARS 10	MARS 10	MARS 10	MARS 10	ATLS 26	ATLS 26	ATLS 26	ATLS 26
	11.02	159	MERC 5	MERC 5	MERC 5	MERC 5	MERC 5	MERC 5	MERC 5	MERC 5	VENS 21	VENS 21	VENS 21	VENS 21
	13.85	126	MERC 6	MERC 6	MERC 6	MERC 6	MERC 6	MERC 6	MERC 6	MERC 6	VENS 22	VENS 22	VENS 22	VENS 22
	17.21	102	MERC 6	MERC 6	MERC 6	MERC 6	MERC 6	MERC 6	MERC 6	MERC 6	VENS 21	VENS 21	VENS 21	VENS 21
	20.41	86	MERC 6	MERC 6	MERC 6	MERC 6	MERC 6	MERC 6	MERC 6	MARS 12	VENS 23	VENS 23	VENS 23	VENS 23
	24.00	73	MERC 7	MERC 7	MERC 7	MERC 7	MERC 7	MERC 7	MERC 7	MARS 14	VENS 22	VENS 22	VENS 22	ATLS 38
Triple	31.63	55	MERC 6	MERC 6	MERC 6	MERC 6	MERC 6	MARS 13	MARS 13	VENS 19	ATLS 32	ATLS 32	LUNA 39	
	36.56	48	MERC 7	MERC 7	MERC 7	MERC 7	MERC 7	MARS 15	MARS 15	VENS 23	ATLS 41	ATLS 41	ATLS 41	
	43.78	40	MERC 5d	MERC 5d	MERC 5d	MERC 5d	MARS 10d	MARS 16	MARS 16	VENS 24	ATLS 41	ATLS 41		
	54.45	32	MERC 8	MERC 8	MERC 8	MERC 8	MARS 17	MARS 17	VENS 24	ATLS 42	ATLS 42	LUNA 51	ERTH 72	
	64.42	27	MERC 8	MERC 8	MERC 8	MERC 8	MARS 17	MARS 17	VENS 24	ATLS 42	LUNA 51	ERTH 72	ERTH 72	
	69.63	25	MERC 7	MERC 7	MERC 7	MERC 7	MARS 17	MARS 17	VENS 22	ATLS 39	ATLS 39	LUNA 49	ERTH 68	
	80.01	22	MERC 8	MERC 8	MERC 8	MARS 17	MARS 17	VENS 24	ATLS 42	ATLS 42	ATLS 42	ERTH 74	ERTH 74	
	91.41	19.1	MERC 8	MERC 8	MERC 8	MARS 17	MARS 17	ATLS 38	ATLS 38	ATLS 38	ERTH 54			
	99.38	17.6	MERC 7	MERC 7	MERC 7	MARS 15	VENS 23	ATLS 40	ATLS 40	ATLS 40	LUNA 49	ERTH 70	PLRS 105	
	111.5	15.7	MERC 8	MERC 8	MERC 8	MARS 17	VENS 24	ATLS 42	ATLS 42	ATLS 42	ERTH 74	ERTH 74	PLRS 120	
	121.4	14.4	MERC 7q	MERC 7q	MARS 17q	MARS 17q	ATLS 38q	ATLS 38q	LUNA 51q	ERTH 74q	PLRS 120q	PLRS 120q	PLRS 120q	
	138.5	12.6	MERC 7	MARS 15	MARS 15	MARS 15	VENS 23	ATLS 39	LUNA 49	ERTH 70	PLRS 110	DELT 144	DELT 144	
159.8	11.0	MERC 8	MERC 8	MARS 17	MARS 17	ATLS 43q	ATLS 43q	ERTH 74q	ERTH 74q	PLRS 120q	DELT 154q	DELT 154q		
Quadruple	193.1	9.1	MERC 7	MARS 15	MARS 15	VENS 20	ATLS 33	ERTH 60	ERTH 76q	PLRS 120q	DELT 154q	DELT 154q	NEP+ 226q	
	206.2	8.5	MERC 8	MARS 17	MARS 17	VENS 24	ATLS 43	ERTH 76	PLRS 120	DELT 154	DELT 154	NEP+ 226	NEP+ 226	
	238.2	7.3	MERC 8	MARS 17	MARS 17	VENS 24	ATLS 43	ERTH 76	ERTH 76	PLRS 120	DELT 154	NEP+ 227	NEP+ 227	
	265.4	6.6	MARS 10t	MARS 17	MARS 17	ATLS 43	ATLS 43	ERTH 76	PLRS 120	DELT 154	NEP+ 227	NEP+ 227	ORN+ 316	
	295.7	5.9	MARS 17	MARS 17	VENS 24	ATLS 43	LUNA 51	ERTH 72	PLRS 115	DELT 147	NEP+ 213	ORN+ 316	ORN+ 316	
	330.1	5.3	MARS 18	MARS 18	VENS 23	ATLS 40	ERTH 76	PLRS 120	PLRS 120	NEP+ 228	NEP+ 228	ORN+ 316	ORN+ 316	
	369.8	4.7	MARS 18	VENS 24	VENS 24	ATLS 43	ERTH 76	PLRS 120	PLRS 120	NEP+ 229	ORN+ 274			
	412.1	4.2	MARS 18	VENS 24	ATLS 43	ATLS 43	ERTH 72	PLRS 115	DELT 148	NEP+ 215	ORN+ 316			
	459.0	3.8	MARS 16	VENS 23	ATLS 40	LUNA 50	ERTH 76	PLRS 120	DELT 154	NEP+ 230	ORN+ 316			
	532.5	3.3	MARS 18	ATLS 43	ATLS 43	LUNA 51	PLRS 115	DELT 149	NEP+ 217	ORN+ 316				
	617.9	2.8	VENS 23	ATLS 40	LUNA 51	ERTH 76	PLRS 120	NEP+ 232	NEP+ 232	NEP+ 232				
	660.6	2.6	ERTH 76qu	ERTH 76qu	ERTH 76qu	ERTH 76qu	PLRS 120qu	NEP+ 232qu	NEP+ 232qu	NEP+ 232qu				
741.2	2.4	VENS 24	ATLS 43	ERTH 72	PLRS 115qu	DELT 150	NEP+ 219	ORN+ 316						
Quintuple	900.3	1.9	ATLS 40	LUNA 51	ERTH 76qu	PLRS 115qu	DELT 154qu	NEP+ 234qu	ORN+ 316qu					
	1057.0	1.7	LUNA 42	ERTH 60	PLRS 120qu	PLRS 120qu	NEP+ 183	ORN+ 316qu						
	1255.0	1.4	LUNA 42q	ERTH 76	PLRS 115	DELT 154	NEP+ 236							
	1.0	ERTH 72	PLRS 115	PLRS 115	NEP+ 238	ORN+ 316								

Shaded areas that are **bold** require an electric fan.
Shaded areas that are **bold and italicized** require an alternate lubricant to achieve selection, contact factory for lubrication specification.

① Contact Rexnord for application details.
② Example: “**VENS 19**” requires a Venus size reducer rated for 19,000 lb-in torque.

d = double reduction t = triple reduction q = quadruple reduction qu = quintuple reduction

1750 RPM - Class II - Service Factor = 1.40

TABLE 10

Low speed shaft torque rating (1000 lb-in) ①②
(Horizontal mounting)

Reduction	Nominal Ratio	Approx. Output RPM	Motor Horsepower & Frame Size												
			1 HP 143TC	1.5 HP 145TC	2 HP 145TC	3 HP 182TC	5 HP 184TC	7.5 HP 123TC	10 HP 215TC	15 HP 254TC	20 HP 256TC	25 HP 184TC	30 HP 286TC		
Single	3.53	496	MERC 4	MERC 4	MERC 4	MERC 4	MERC 4	MERC 4	MERC 4	MERC 4	VENS 16	VENS 16	VENS 16	VENS 16	
	4.39	399	MERC 4	MERC 4	MERC 4	MERC 4	MERC 4	MERC 4	MERC 4	MERC 4	VENS 16	VENS 16	VENS 16	VENS 16	
	6.12	286	MERC 3	MERC 3	MERC 3	MERC 3	MERC 3	MERC 3	MERC 3	MARS 7	VENS 17	VENS 17	VENS 17	VENS 17	
Double	9.30	188	ATLS 26	ATLS 26	ATLS 26	ATLS 26	ATLS 26	ATLS 26	ATLS 26	ATLS 26	ATLS 26	ATLS 26	ATLS 26		
	11.02	159	MERC 5	MERC 5	MERC 5	MERC 5	MERC 5	MERC 5	MERC 5	MERC 5	VENS 21	VENS 21	VENS 21	VENS 21	
	13.85	126	MERC 6	MERC 6	MERC 6	MERC 6	MERC 6	MERC 6	MERC 6	MARS 12	VENS 22	VENS 22	VENS 22	VENS 22	
	17.21	102	MERC 6	MERC 6	MERC 6	MERC 6	MERC 6	MERC 6	MARS 13	MARS 13	VENS 21	VENS 21	VENS 21	ATLS 38	
	20.41	86	MERC 6	MERC 6	MERC 6	MERC 6	MERC 6	MERC 6	MARS 12	MARS 12	VENS 23	VENS 23	VENS 23	ATLS 38	
	24.00	73	MERC 7	MERC 7	MERC 7	MERC 7	MERC 7	MERC 7	MARS 14	MARS 14	VENS 22	ATLS 38	ATLS 38	ATLS 38	
Triple	31.63	55	MERC 6	MERC 6	MERC 6	MERC 6	MARS 13	MARS 13	VENS 19	ATLS 32	ATLS 32	ERTH 56	ERTH 56		
	36.56	48	MERC 7	MERC 7	MERC 7	MERC 7	MARS 15	MARS 15	VENS 23	ATLS 41	ATLS 41	LUNA 51	ERTH 70		
	43.78	40	MERC 5d	MERC 5d	MERC 5d	MERC 7	MARS 16	MARS 16	VENS 24	ATLS 41	LUNA 51	ERTH 72	ERTH 72		
	54.45	32	MERC 8	MERC 8	MERC 8	MERC 8	MARS 17	VENS 24	ATLS 42	ATLS 42	ERTH 72	ERTH 72	PLRS 120		
	64.42	27	MERC 8	MERC 8	MERC 8	MARS 17	MARS 17	VENS 24	ATLS 42	LUNA 51	ERTH 72	PLRS 120	PLRS 120		
	69.63	25	MERC 7	MERC 7	MERC 7	MARS 17	MARS 17	ATLS 39	ATLS 39	LUNA 49	ERTH 68	PLRS 105	PLRS 105		
	80.01	22	MERC 8	MERC 8	MERC 8	MARS 17	VENS 24	ATLS 42	ATLS 42	ERTH 74	ERTH 74	PLRS 120	PLRS 120		
	91.41	19.1	MERC 8	MERC 8	MARS 17	MARS 17	ATLS 38	ATLS 38	ERTH 54						
	99.38	17.6	MERC 7	MARS 15	MARS 15	MARS 15	VENS 23	ATLS 40	LUNA 49	ERTH 70	PLRS 105	DELT 143	DELT 143		
	111.5	15.7	MERC 8	MERC 8	MARS 17	MARS 17	ATLS 42	ATLS 42	ERTH 74	PLRS 120	PLRS 120				
	121.4	14.4	MERC 7q	MARS 17q	MARS 17q	MARS 17q	ATLS 38q	LUNA 51q	ERTH 74q	PLRS 120q	PLRS 120q	DELT 153q	NEP+ 223q		
	138.5	12.6	MERC 7	MARS 15	MARS 15	VENS 23	ATLS 39	LUNA 49	ERTH 70	PLRS 110	DELT 144				
159.8	11.0	MERC 8	MARS 17	MARS 17	VENS 24q	ATLS 43q	ERTH 74q	ERTH 74q	PLRS 120q	DELT 154q	NEP+ 224q	NEP+ 224q			
Quadruple	193.1	9.1	MARS 15	MARS 15	VENS 20	ATLS 33	ERTH 60	ERTH 76q	PLRS 120q	DELT 154q	NEP+ 226q	NEP+ 226q	ORN+ 316q		
	206.2	8.5	MARS 17	MARS 17	VENS 24	ATLS 43	LUNA 51	PLRS 120	DELT 154	DELT 154	NEP+ 226	ORN+ 274			
	238.2	7.3	MARS 17	MARS 17	VENS 24	ATLS 43	ERTH 76	PLRS 120	PLRS 120	NEP+ 227	NEP+ 227	ORN+ 316	ORN+ 316		
	265.4	6.6	MARS 17	VENS 24	VENS 24	ATLS 43	ERTH 76	PLRS 120	PLRS 120	NEP+ 227	NEP+ 227	ORN+ 316	ORN+ 316		
	295.7	5.9	MARS 17	VENS 24	ATLS 43	ATLS 43	ERTH 72	PLRS 115	DELT 147	NEP+ 213	ORN+ 316	ORN+ 316			
	330.1	5.3	MARS 18	VENS 23	ATLS 40	LUNA 50	ERTH 76	PLRS 120	DELT 154	NEP+ 228	ORN+ 316	ORN+ 316			
	369.8	4.7	MARS 18	ATLS 43	ATLS 43	LUNA 51	PLRS 120	DELT 140	NEP+ 229	ORN+ 274	ORN+ 274	ORN+ 316	ORN+ 316		
	412.1	4.2	VENS 24	ATLS 43	ATLS 43	ERTH 72	PLRS 115	DELT 148	NEP+ 215	ORN+ 316	ORN+ 316	ORN+ 316	ORN+ 316		
	459.0	3.8	VENS 23	ATLS 40	LUNA 50	ERTH 76	PLRS 120	DELT 154	NEP+ 230	ORN+ 316	ORN+ 316	ORN+ 316	ORN+ 316		
	532.5	3.3	VENS 24	ATLS 43	LUNA 51	PLRS 115	DELT 149	NEP+ 217	ORN+ 316	ORN+ 316	ORN+ 316	ORN+ 316	ORN+ 316		
	617.9	2.8	ATLS 40	LUNA 51	ERTH 76	PLRS 120	NEP+ 232	NEP+ 232							
	660.6	2.6	ERTH 76qu	ERTH 76qu	ERTH 76qu	PLRS 120qu	DELT 154qu	NEP+ 232qu	NEP+ 232qu	ORN+ 316	ORN+ 316	ORN+ 316	ORN+ 316		
741.2	2.4	ATLS 43	ERTH 72	ERTH 72	DELT 150	NEP+ 219	ORN+ 316	ORN+ 316	ORN+ 316	ORN+ 316	ORN+ 316	ORN+ 316			
Quintuple	900.3	1.9	ATLS 40	ERTH 76qu	PLRS 115qu	DELT 150qu	NEP+ 234qu	ORN+ 316qu	ORN+ 316qu	ORN+ 316qu	ORN+ 316qu	ORN+ 316qu	ORN+ 316qu		
	1057.0	1.7	ERTH 60	PLRS 120qu	PLRS 120qu	DELT 154qu	ORN+ 274								
	1255.0	1.4	ERTH 76	PLRS 115	PLRS 115	NEP+ 236									
	1785.0	1.0	PLRS 115	DELT 152	NEP+ 238	NEP+ 238									

Shaded areas that are **bold** require an electric fan.
 Shaded areas that are **bold and italicized** require an alternate lubricant to achieve selection, contact factory for lubrication specification.
 Average ambient temperature below 84°F. See selection procedures page 7 for higher ambient temperatures.

- ① Contact Rexnord for application details.
- ② Example: “VENS 19” requires a Venus size reducer rated for 19,000 lb-in torque.

d = double reduction t = triple reduction q = quadruple reduction qu = quintuple reduction

1750 RPM - Class III - Service Factor = 2.00

TABLE 11

Low speed shaft torque rating (1000 lb-in) ①②
(Horizontal mounting)

Reduction	Nominal Ratio	Approx. Output RPM	Motor Horsepower & Frame Size											
			1 HP 143TC	1.5 HP 145TC	2 HP 145TC	3 HP 182TC	5 HP 184TC	7.5 HP 123TC	10 HP 215TC	15 HP 254TC	20 HP 256TC	25 HP 184TC	30 HP 286TC	
Single	3.53	496	MERC 4	MERC 4	MERC 4	MERC 4	MERC 4	MERC 4	MERC 4	MERC 4	VENS 16	VENS 16	VENS 16	VENS 16
	4.39	399	MERC 4	MERC 4	MERC 4	MERC 4	MERC 4	MERC 4	MERC 4	MERC 4	VENS 16	VENS 16	VENS 16	VENS 16
	6.12	286	MERC 3	MERC 3	MERC 3	MERC 3	MERC 3	MARS 7	MARS 7	MARS 7	VENS 17	VENS 17	VENS 17	VENS 17
Double	9.30	188	MARS 10	MARS 10	MARS 10	MARS 10	MARS 10	MARS 10	MARS 10	MARS 10	ATLS 26	ATLS 26	ATLS 26	
	11.02	159	MERC 5	MERC 5	MERC 5	MERC 5	MERC 5	MARS 10	MARS 10	MARS 10	VENS 21	VENS 21	VENS 21	ATLS 36
	13.85	126	MERC 6	MERC 6	MERC 6	MERC 6	MERC 6	MARS 12	MARS 12	MARS 12	VENS 22	VENS 22	ATLS 38	ATLS 38
	17.21	102	MERC 6	MERC 6	MERC 6	MERC 6	MERC 6	MARS 13	MARS 13	MARS 13	VENS 21	ATLS 38	ATLS 38	ATLS 38
	20.41	86	MERC 6	MERC 6	MERC 6	MERC 6	MERC 6	MARS 12	MARS 12	MARS 12	VENS 23	ATLS 38	ATLS 38	LUNA 41
	24.00	73	MERC 7	MERC 7	MERC 7	MERC 7	MARS 14	MARS 14	MARS 14	MARS 14	VENS 22	ATLS 38	ATLS 38	LUNA 48
Triple	31.63	55	MERC 6	MERC 6	MERC 6	MARS 13	MARS 13	VENS 19	ATLS 32	ATLS 32	LUNA 39	ERTH 56	ERTH 66t	ERTH 66t
	36.56	48	MERC 7	MERC 7	MERC 7	MARS 15	MARS 15	VENS 23	ATLS 41	ATLS 41	ATLS 41	LUNA 51	ERTH 70	PLRS 110
	43.78	40	MERC 5d	MERC 5d	MERC 7	MARS 10d	MARS 16	VENS 24	ATLS 41	ATLS 41	LUNA 51	ERTH 72	PLRS 115	PLRS 115
	54.45	32	MERC 8	MERC 8	MERC 8	MARS 17	VENS 24	ATLS 42	ATLS 42	ATLS 42	ERTH 72	PLRS 120	PLRS 120	PLRS 120
	64.42	27	MERC 8	MERC 8	MARS 17	MARS 17	VENS 24	ATLS 42	ATLS 42	LUNA 51	ERTH 72	PLRS 120	PLRS 120	DELT 135
	69.63	25	MERC 7	MERC 7	MARS 17	MARS 17	ATLS 39	ATLS 39	ATLS 39	LUNA 49	PLRS 105	PLRS 105	DELT 142	DELT 142
	80.01	22	MERC 8	MARS 17	MARS 17	MARS 17	ATLS 42	ATLS 42	ATLS 42	ERTH 74	PLRS 120	PLRS 120	DELT 152	DELT 152
	91.41	19.1	MERC 8	MARS 17	MARS 17	ATLS 38	ATLS 38	ERTH 54	ERTH 54	ERTH 54				
	99.38	17.6	MERC 7	MARS 15	MARS 15	VENS 23	ATLS 40	LUNA 49	ERTH 70	ERTH 70	PLRS 105	DELT 143		
	111.5	15.7	MERC 8	MARS 17	MARS 17	VENS 24	ATLS 42	ERTH 74	ERTH 74	ERTH 74	PLRS 120			
	121.4	14.4	MARS 17q	MARS 17q	MARS 17q	ATLS 38q	LUNA 51q	ERTH 74q	ERTH 74q	PLRS 120q	PLRS 120q	NEP+ 223q	NEP+ 223q	ORN+ 274q
	138.5	12.6	MARS 15	MARS 15	VENS 23	ATLS 39	LUNA 49	ERTH 70	ERTH 70	PLRS 110	DELT 144	NEP+ 224q	ORN+ 316q	ORN+ 316q
159.8	11.0	MARS 17	MARS 17	VENS 24q	ATLS 43q	ERTH 74q	ERTH 74q	ERTH 74q	PLRS 120q	DELT 154q				
193.1	9.1	MARS 15	VENS 20	ATLS 33	LUNA 40	ERTH 76q	ERTH 76q	DELT 154	NEP+ 226q	ORN+ 316q				
Quadruple	206.2	8.5	MARS 17	VENS 24	ATLS 43	ATLS 43	PLRS 120	DELT 154	DELT 154	NEP+ 226	ORN+ 274			
	238.2	7.3	MARS 17	VENS 24	ATLS 43	LUNA 51	ERTH 76	PLRS 120	DELT 154	NEP+ 227	ORN+ 316			
	265.4	6.6	MARS 17	ATLS 43	ATLS 43	ERTH 76	PLRS 120	DELT 154	NEP+ 227	ORN+ 274				
	295.7	5.9	VENS 24	ATLS 43	ATLS 43	ERTH 72	PLRS 115	DELT 147	NEP+ 213	ORN+ 316				
	330.1	5.3	VENS 23	ATLS 40	LUNA 50	ERTH 76	PLRS 120	NEP+ 228	NEP+ 228	ORN+ 316				
	369.8	4.7	VENS 24	ATLS 43	LUNA 51	ERTH 76	PLRS 120	NEP+ 229	ORN+ 274					
	412.1	4.2	ATLS 43	ATLS 43	ERTH 72	PLRS 115	DELT 148	NEP+ 215	ORN+ 316					
	459.0	3.8	ATLS 40	LUNA 50	ERTH 76	PLRS 120	DELT 154	NEP+ 230	ORN+ 316					
	532.5	3.3	ATLS 43	LUNA 51	PLRS 115	PLRS 115	NEP+ 217	ORN+ 316						
	617.9	2.8	LUNA 51	ERTH 76	PLRS 120	DELT 133	NEP+ 232							
	660.6	2.6	ERTH 76qu	ERTH 76qu	PLRS 120qu	DELT 154qu	NEP+ 232qu							
	741.2	2.4	ERTH 72	PLRS 115qu	DELT 150	NEP+ 219	ORN+ 316							
900.3	1.9	ERTH 76qu	PLRS 115qu	DELT 154qu	NEP+ 234qu	ORN+ 316qu								
1057.0	1.7	PLRS 120qu	PLRS 120qu	DELT 154qu	ORN+ 316qu									
Quintuple	1255.0	1.4	ERTH 76	DELT 154	DELT 154	ORN+ 274								
	1785.0	1.0	PLRS 115	NEP+ 238	NEP+ 238									

Shaded areas that are **bold** require an electric fan.
 Shaded areas that are **bold and italicized** require an alternate lubricant to achieve selection, contact factory for lubrication specification.
 Average ambient temperature below 84°F. See selection procedures page 7 for higher ambient temperatures.

- ① Contact Rexnord for application details.
- ② **Example: "VENS 19" requires a Venus size reducer rated for 19,000 lb-in torque.**

d = double reduction t = triple reduction q = quadruple reduction qu = quintuple reduction

Reducer Only — Mercury & Mars

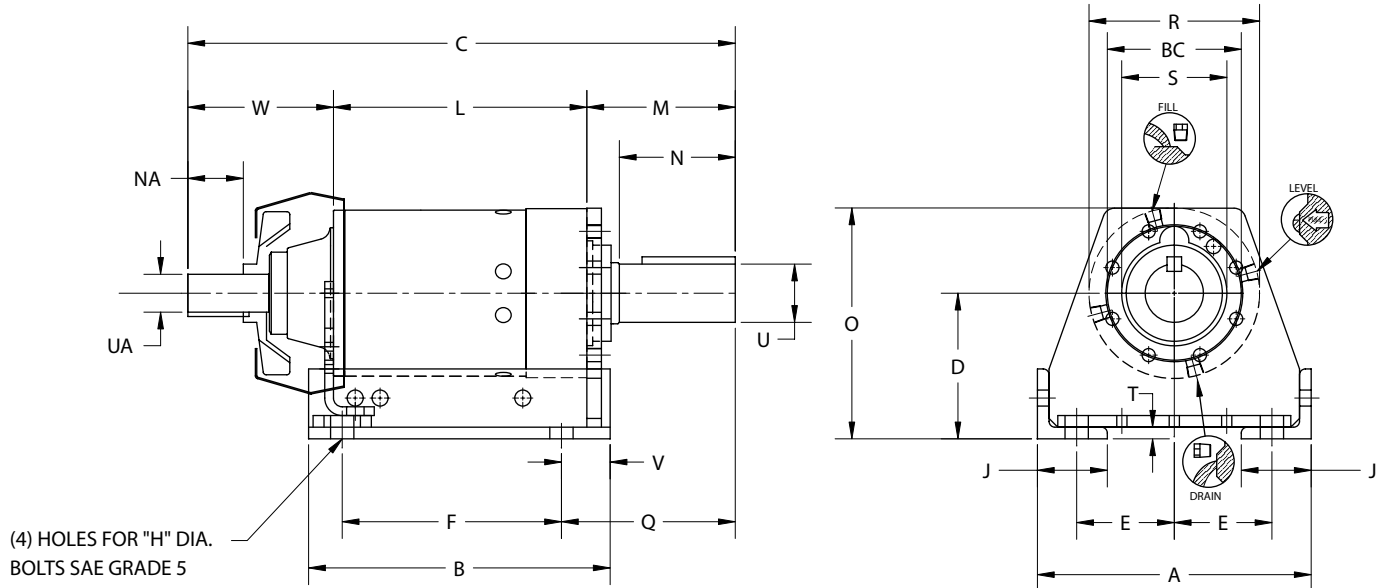

Dimensions are in Inches.

Series	A	B		BC	C ①			D	E	F	H bolt	J	L ②			M	O	Q
		s,d,t	quad		s,d	t	quad						s,d	t	quad			
Mercury	11.75	12.94	15.13	5.750	19.88	22.13	24.38	6.25	4.19	9.41	7/8	3.00	8.63	10.88	13.13	5.50	9.91	6.59
Mars	11.75	12.94	15.13	5.750	21.25	23.50	25.75	6.25	4.19	9.41	7/8	3.00	8.63	10.88	13.13	6.37	9.91	7.46

Series	R	S	T	V	W ③	Low Speed Shaft			High Speed Shaft			Avg. Wt. Lbs	
						N	U ④	Key	NA		UA ④		Key
	max.	max.	w/o fan	w/ fan									
Mercury	7.32	4.50	0.50	2.09	5.75	4.15	2.000	1/2 x 1/2 x 3	3.00	1.88	1.375	5/16 x 5/16 x 2	144
Mars	7.32	4.50	0.50	2.09	6.25	4.98	2.500	5/8 x 5/8 x 3 7/8	3.50	2.38	1.625	3/8 x 3/8 x 2-1/2	150

s = single reduction d = double reduction t = triple reduction quad = quadruple reduction

① Add 0.66 w/Backstop

② Add 1.12 w/Backstop

③ Subtract 0.46 w/Backstop

④ Tolerances: 3.000" diameter or less +.000/-.001 over 3.000" Diameter +.000/-.002

NOTE: Dimensions subject to change. Certified dimensions of ordered material furnished upon request.

Reducer Only — Venus through Jupiter Plus

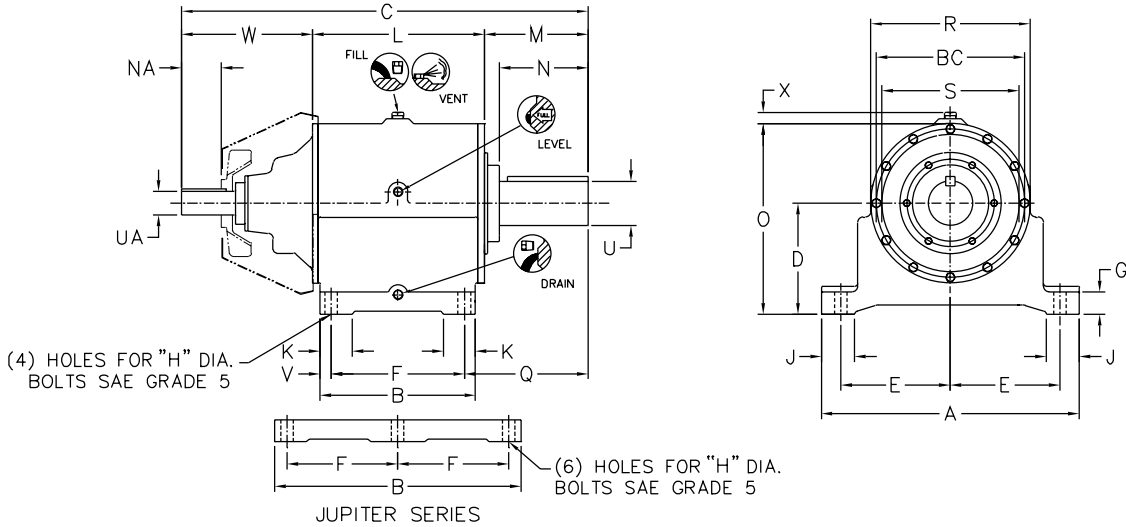

Dimensions are in Inches.

Series	A	B	BC	C		D	E	F	G	H bolt	J	K	L		M
				s,d,t	quad								s,d,t	quad	
Venus	18.00	11.75	10.500	29.73	28.52 ①	7.75	8.00	9.53	1.25	1	2.25	2.62	13.13	13.13	6.76
Atlas	18.00	11.75	10.500	30.73	29.52 ①	7.75	8.00	9.53	1.25	1	2.25	2.62	13.13	13.13	7.76
Luna	18.00	11.75	10.500	30.73	29.52 ①	7.75	8.00	9.53	1.25	1	2.25	2.62	13.13	13.13	7.76
Earth	23.25	11.75	13.375	34.08	35.71	8.75	9.88	9.53	2.00	1	3.13	2.62	13.06	13.13	9.58
Polaris	23.25	14.00	13.375	36.30	37.93	10.00	9.88	11.75	2.00	1	3.00	2.88	15.53	15.60	9.33
Delta	23.25	14.00	13.375	36.30	37.93	10.00	9.88	11.75	2.00	1	3.00	2.88	15.53	15.60	9.33
Neptune	29.25	11.69	18.250	42.79	42.69	11.25	12.88	8.19	2.75	1-1/4	4.00	4.00	13.43	13.43	16.20
Neptune Plus	29.25	11.69	18.250	42.79	42.69	11.25	12.88	8.19	2.75	1-1/4	4.00	4.00	13.43	13.43	16.20
Orion Plus	29.25	19.62	18.250	46.21	46.11	11.25	12.88	16.00	2.75	1-1/4	4.00	5.00	21.24	21.24	11.81
Saturn Plus	33.25	19.86	21.625	51.58	54.05	12.88	14.63	11.00	2.75	1-1/2	5.88	7.00	21.58	21.58	15.75
Titan Plus	33.25	19.86	21.625	51.58	54.05	12.88	14.63	16.00	2.75	1-1/2	5.88	7.00	21.58	21.58	15.75
Jupiter Plus	33.25	28.88	28.500	62.94	62.94	16.50	14.63	12.50	2.75	1-1/2	4.50	4.50	30.63	30.63	18.06

Series	O	Q	R	S max.	V	W		X	Low Speed Shaft		
						s,d,t	quad		N	U ②	Key
Venus	13.50	8.63	11.50	7.28	1.11	9.84	8.63 ①	1.00	5.50	2.750	5/8 x 5/8 x 4-1/8
Atlas	13.50	9.63	11.50	7.28	1.11	9.84	8.63 ①	1.00	6.50	3.250	3/4 x 3/4 x 5-1/8
Luna	13.50	9.63	11.50	7.28	1.11	9.84	8.63 ①	1.00	6.50	3.250	3/4 x 3/4 x 5-1/8
Earth	15.94	11.38	14.38	11.90	1.11	11.44	13.00	1.00	7.00	3.500	7/8 x 7/8 x 5-1/2
Polaris	17.19	11.29	14.38	9.14	1.13	11.44	13.00	1.00	8.00	4.000	1 x 1 x 6-1/2
Delta	17.19	11.29	14.38	9.14	1.13	11.44	13.00	1.00	8.00	4.000	1 x 1 x 6-1/2
Neptune	20.94	18.83	19.38	16.52	1.75	13.16	13.06	1.00	9.00	4.500	1 x 1 x 7-1/4
Neptune Plus	20.94	18.83	19.38	16.52	1.75	13.16	13.06	1.00	9.00	4.500	1 x 1 x 7-1/4
Orion Plus	20.94	14.37	19.38	13.00	1.81	13.16	13.06	1.00	10.00	5.000	1-1/4 x 1-1/4 x 9-1/4
Saturn Plus	24.25	21.84	22.75	20.02	3.63	14.25	16.72	1.00	11.05	6.500	1-1/2 x 1-1/2 x 9-1/4
Titan Plus	24.25	18.54	22.75	20.02	1.93	14.25	16.72	1.00	11.05	6.500	1-1/2 x 1-1/2 x 9-1/4
Jupiter Plus	31.50	20.88	30.00	26.39	1.94	14.25	14.25	3.50	12.25	7.250	1-3/4 x 1-1/2 x 9-3/4

Series	High Speed Shaft								Avg. Wt. Lbs
	NA				UA ②		Key		
	w/o fan		w/ fan		s,d,t	quad	s,d,t	quad	
Venus	4.25	3.50	2.88	2.50					1.875
Atlas	4.25	3.50	2.88	2.50	1.875	1.625	1/2 x 1/2 x 3-3/4	3/8 x 3/8 x 2-1/2	325
Luna	4.25	3.50	2.88	2.50	1.875	1.625	1/2 x 1/2 x 3-3/4	3/8 x 3/8 x 2-1/2	325
Earth	4.50	4.25	3.25	2.88	2.125	1.875	1/2 x 1/2 x 4	1/2 x 1/2 x 3-3/4	481
Polaris	4.50	4.25	3.25	3.25	2.125	1.875	1/2 x 1/2 x 4	1/2 x 1/2 x 3-3/4	702
Delta	4.50	4.25	3.25	3.25	2.125	1.875	1/2 x 1/2 x 4	1/2 x 1/2 x 3-3/4	702
Neptune	5.68	4.50	3.56	3.25	2.500	2.125	5/8 x 5/8 x 5-1/8	1/2 x 1/2 x 4	923
Neptune Plus	5.68	4.50	3.56	3.25	2.500	2.125	5/8 x 5/8 x 5-1/8	1/2 x 1/2 x 4	923
Orion Plus	5.68	4.50	3.56	3.25	2.500	2.125	5/8 x 5/8 x 5-1/8	1/2 x 1/2 x 4	1146
Saturn Plus	6.50	5.68	4.38	3.56	3.000	2.500	3/4 x 3/4 x 5-7/8	5/8 x 5/8 x 5-1/8	2000
Titan Plus	6.50	5.68	4.38	3.56	3.000	2.500	3/4 x 3/4 x 5-7/8	5/8 x 5/8 x 5-1/8	2000
Jupiter plus	6.50	6.50	4.38	4.38	3.000	3.000	3/4 x 3/4 x 5-7/8	3/4 x 3/4 x 5-7/8	3470

s = single reduction d = double reduction t = triple reduction quad = quadruple reduction

① Add 0.66 w/ Backstop

② TOLERANCES: 3.000" Diameter or less +.000/-0.001 over 3.000" Diameter +.000/-0.002

NOTE: Dimensions subject to change. Certified dimensions of ordered material furnished upon request.

Motor Mount — Mercury & Mars

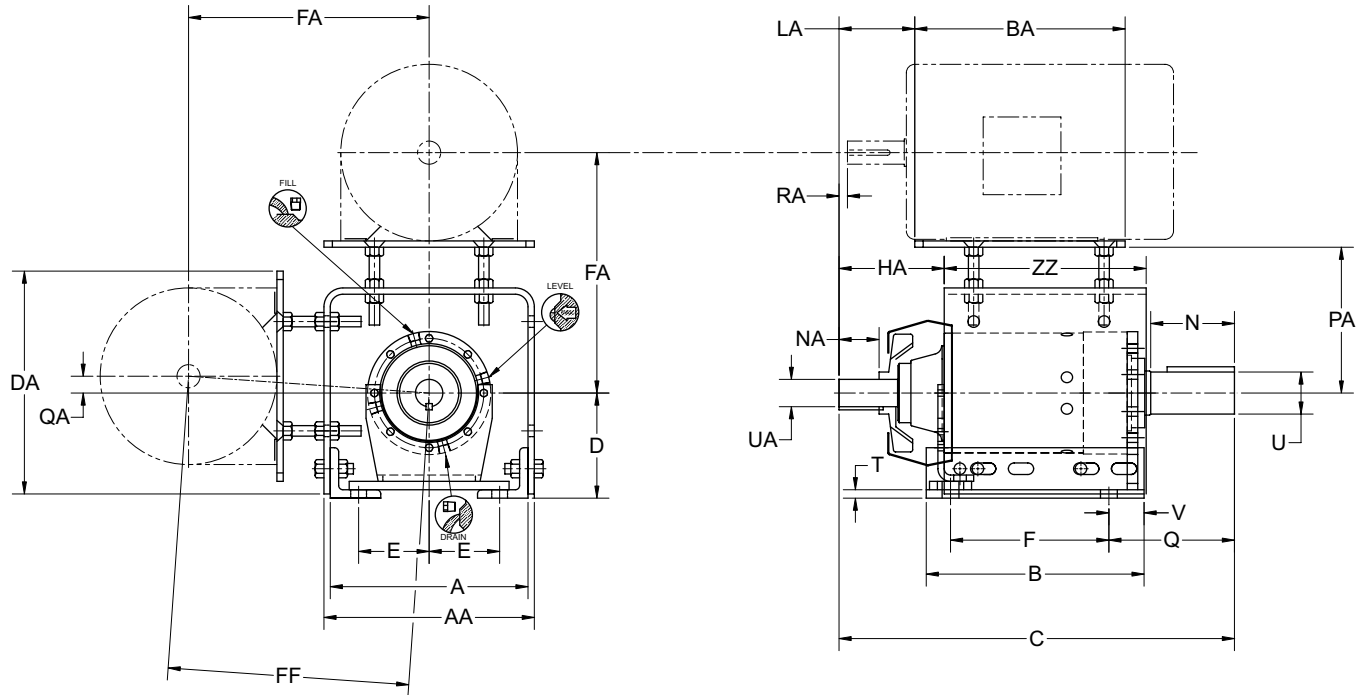

Dimensions are in inches.

Series	A	AA	B		BA	C ①			D	DA	E	F	H bolt	HA	PA	
			s,d,t	quad		s,d	t	quad							min.	max.
Mercury	11.75	12.50	12.94	15.13	12.50	19.88	22.13	24.38	6.25	13.50	4.19	9.41	7/8	5.75	7.53	9.81
Mars	11.75	12.50	12.94	15.13	12.50	21.25	23.50	25.75	6.25	13.50	4.19	9.41	7/8	6.25	7.53	9.81

Series	Q	QA	T	V	ZZ	Low Speed Shaft			High Speed Shaft				Avg. Wt. Lbs
						N	U ③	Key	NA		Key		
									w/o fan	w/ fan		UA ③	
Mercury	6.59	1.00	0.50	2.09	12.00	4.15	2.000	1/2 x 1/2 x 3	3.00	1.88	1.375	5/16 x 5/16 x 2	205
Mars	7.46	1.00	0.50	2.09	12.00	4.98	2.500	5/8 x 5/8 x 3-7/8	3.50	2.38	1.625	3/8 x 3/8 x 2-1/2	211

Motor Frame ②	Series	FA		FF		LA	RA
		min.	max.	min.	max.		
143T / 145T	Mercury	11.41	13.69	11.45	13.73	4.00	0.50
	Mars	11.41	13.69	11.45	13.73	4.50	1.00
182T / 184T	Mercury	12.41	14.69	12.45	14.72	4.00	0.13
	Mars	12.41	14.69	12.45	14.72	4.50	0.63
213T / 215T	Mercury	13.16	15.44	13.20	15.47	4.00	-0.50
	Mars	13.16	15.44	13.20	15.47	4.50	0.00
254T / 256T	Mercury	14.16	16.44	14.20	16.47	6.25	-0.75
	Mars	14.16	16.44	14.20	16.47	6.75	-0.25

s = single reduction d = double reduction t = triple reduction quad = quadruple reduction

① Add 0.66 w/ Backstop

② Contact factory for motor frame sizes not listed

③ TOLERANCES: 3.000" Diameter or less +.000/-0.001 over 3.000" Diameter +.000/-0.002

NOTE: Dimensions subject to change. Certified dimensions of ordered material furnished upon request.

Motor Mount — Venus through Jupiter Plus

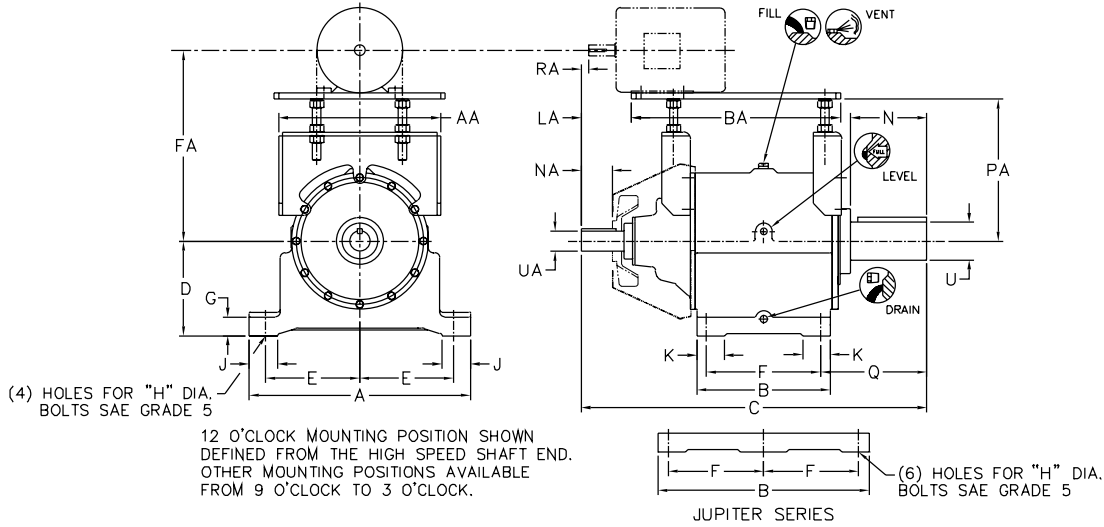

Motor mounts for larger motor frames available - contact factory.

Dimensions are in Inches.

Series	A	AA	B	BA	C		D	E	F	G	H		J	K	LA		PA	
					s,d,t	quad					bolt	s,d,t			quad	min.	max.	
Venus	18.00	14.50	11.75	17.50	29.73	28.52 ①	7.75	8.00	9.53	1.25	1	2.25	2.62	5.50	4.29 ①	11.47	14.29	
Atlas	18.00	14.50	11.75	17.50	30.73	29.52 ①	7.75	8.00	9.53	1.25	1	2.25	2.62	5.50	4.29 ①	11.47	14.29	
Luna	18.00	14.50	11.75	17.50	30.73	29.52 ①	7.75	8.00	9.53	1.25	1	2.25	2.62	5.50	4.29 ①	11.47	14.29	
Earth	23.25	17.00	11.75	19.50	34.08	35.71	8.75	9.88	9.53	2.00	1	3.13	2.62	5.25	6.87	13.22	16.53	
Polaris	23.25	17.00	14.00	22.00	36.30	37.93	10.00	9.88	11.75	2.00	1	3.00	2.88	5.25	6.81	13.22	16.53	
Delta	23.25	17.00	14.00	22.00	36.30	37.93	10.00	9.88	11.75	2.00	1	3.00	2.88	5.25	6.81	13.22	16.53	
Neptune	29.25	22.25	11.69	20.50	42.79	42.69	11.25	12.88	8.19	2.75	1-1/4	4.00	4.00	6.50	6.39	16.72	20.52	
Neptune Plus	29.25	22.25	11.69	20.50	42.79	42.69	11.25	12.88	8.19	2.75	1-1/4	4.00	4.00	6.50	6.39	16.72	20.52	
Orion Plus	29.25	22.25	19.62	29.50	46.21	46.11	11.25	12.88	16.00	2.75	1-1/4	4.00	5.00	6.50	6.39	16.72	20.52	
Saturn Plus	33.25	25.50	19.86	29.50	51.58	54.05	12.88	14.63	11.00	2.75	1-1/2	5.88	7.00	6.50	8.97	17.97	21.24	
Titan Plus	33.25	25.50	19.86	29.50	51.58	54.05	12.88	14.63	16.00	2.75	1-1/2	5.88	7.00	6.50	8.97	17.97	21.24	
Jupiter Plus	33.25	25.50	28.88	38.50	62.94	62.94	16.50	14.63	12.50	2.75	1-1/2	4.50	4.50	6.50	6.50	21.22	24.49	

Series	Q	Low Speed Shaft				High Speed Shaft								Avg. Wt. Lbs
		N	U ③	Key	NA				UA ③		Key			
					w/o fan		w/ fan		s,d,t	quad	s,d,t	quad		
Venus	8.63	5.50	2.750	5/8 x 5/8 x 4-1/8	4.25	3.50	2.88	2.50	1.875	1.625	1/2 x 1/2 x 3-3/4	3/8 x 3/8 x 2-1/2	362	
Atlas	9.63	6.50	3.250	3/4 x 3/4 x 5-1/8	4.25	3.50	2.88	2.50	1.875	1.625	1/2 x 1/2 x 3-3/4	3/8 x 3/8 x 2-1/2	392	
Luna	9.63	6.50	3.250	3/4 x 3/4 x 5-1/8	4.25	3.50	2.88	2.50	1.875	1.625	1/2 x 1/2 x 3-3/4	3/8 x 3/8 x 2-1/2	392	
Earth	11.38	7.00	3.500	7/8 x 7/8 x 5-1/2	4.50	4.25	3.25	2.88	2.125	1.875	1/2 x 1/2 x 4	1/2 x 1/2 x 3-3/4	574	
Polaris	11.29	8.00	4.000	1 x 1 x 6-1/2	4.50	4.25	2.88	3.25	2.125	1.875	1/2 x 1/2 x 4	1/2 x 1/2 x 3-3/4	820	
Delta	11.29	8.00	4.000	1 x 1 x 6-1/2	4.50	4.25	2.88	3.25	2.125	1.875	1/2 x 1/2 x 4	1/2 x 1/2 x 3-3/4	820	
Neptune	18.83	9.00	4.500	1 x 1 x 7-1/4	5.68	4.50	3.56	3.25	2.500	2.125	5/8 x 5/8 x 5-1/8	1/2 x 1/2 x 4	1066	
Neptune Plus	18.83	9.00	4.500	1 x 1 x 7-1/4	5.68	4.50	3.56	3.25	2.500	2.125	5/8 x 5/8 x 5-1/8	1/2 x 1/2 x 4	1066	
Orion Plus	14.37	10.00	5.000	1-1/4 x 1-1/4 x 9-1/4	5.68	4.50	3.56	3.25	2.500	2.125	5/8 x 5/8 x 5-1/8	1/2 x 1/2 x 4	1290	
Saturn Plus	21.84	11.05	6.500	1-1/2 x 1-1/2 x 9-1/4	6.50	5.68	4.38	3.56	3.000	2.500	3/4 x 3/4 x 5-7/8	5/8 x 5/8 x 5-1/8	2215	
Titan Plus	18.54	11.05	6.500	1-1/2 x 1-1/2 x 9-1/4	6.50	5.68	4.38	3.56	3.000	2.500	3/4 x 3/4 x 5-7/8	5/8 x 5/8 x 5-1/8	2215	
Jupiter Plus	20.88	12.25	7.250	1-3/4 x 1-1/2 x 9-3/4	6.50	6.50	4.38	4.38	3.000	3.000	3/4 x 3/4 x 5-7/8	3/4 x 3/4 x 5-7/8	3717	

Motor ② Frame	FA												RA																			
	Venus, Atlas, Luna		Earth		Polaris & Delta		Neptune & Neptune Plus		Orion Plus		Saturn Plus		Titan Plus		Jupiter Plus		Venus, Atlas, Luna		Earth		Polaris & Delta		Neptune & Neptune Plus		Orion Plus		Saturn Plus		Titan Plus		Jupiter Plus	
	min.	max.	min.	max.	min.	max.	min.	max.	min.	max.	min.	max.	min.	max.	s,d,t	quad	s,d,t	quad	s,d,t	quad	s,d,t	quad	s,d,t	quad	s,d,t	quad	s,d,t	quad	s,d,t	quad	s,d,t	quad
143T/145T	15.47	18.29	—	—	—	—	—	—	—	—	—	—	—	—	—	2.00	0.79	—	—	—	—	—	—	—	—	—	—	—	—	—	—	
182T/184T	16.47	19.29	18.35	21.66	18.35	21.66	—	—	—	—	—	—	—	—	—	1.00	-0.21	0.75	2.38	0.75	2.38	—	—	—	—	—	—	—	—	—	—	
213T/215T	17.22	20.04	19.10	22.41	19.10	22.41	22.60	26.40	22.73	26.53	—	—	—	—	—	0.25	—	0.00	1.63	0.00	1.63	1.00	0.90	1.00	0.90	—	—	—	—	—	—	
254T/256T	18.22	21.04	20.10	23.41	20.10	23.41	23.60	27.40	23.73	27.53	24.97	28.24	24.97	28.24	28.22	31.49	0.00	—	0.00	—	0.00	—	0.25	0.14	0.25	0.14	-0.25	2.22	-0.25	2.22	-0.25	-0.25
284T/286T	18.97	21.79	20.85	24.16	20.85	24.16	24.35	28.15	24.48	28.28	25.72	28.99	25.72	28.99	28.97	32.22	0.00	—	-0.63	—	-0.63	—	0.25	—	0.25	—	-0.25	2.22	-0.25	2.22	-0.25	-0.25
324T/326T	—	—	21.85	25.16	21.85	25.16	25.35	29.15	25.48	29.28	26.72	29.99	26.72	29.99	29.97	33.22	—	—	-0.50	—	-0.50	—	-0.63	—	-0.63	—	-0.50	—	-0.50	1.97	-0.50	-0.50
364T/365T	—	—	—	—	22.85	26.16	26.35	30.15	26.48	30.28	27.72	30.99	27.72	30.99	30.97	34.22	—	—	—	—	-0.50	—	0.00	—	0.00	—	-1.38	—	-1.38	—	-1.38	-1.38
404T/405T	—	—	—	—	—	—	—	27.48	31.28	28.72	31.99	28.72	31.99	31.97	35.22	—	—	—	—	—	—	—	—	—	-0.38	—	-0.38	—	-0.38	—	-0.38	—

s = single reduction d = double reduction t = triple reduction quad = quadruple reduction
 ① Add 0.66 w/ Backstop ② Contact factory for motor frame sizes other than "T" frame motors
 ③ TOLERANCES: 3.000" Diameter or less +.000/- .001 over 3.000" Diameter +.000/- .002

NOTE: Dimensions subject to change. Certified dimensions of ordered material furnished upon request.

Slidebase — Mercury & Mars

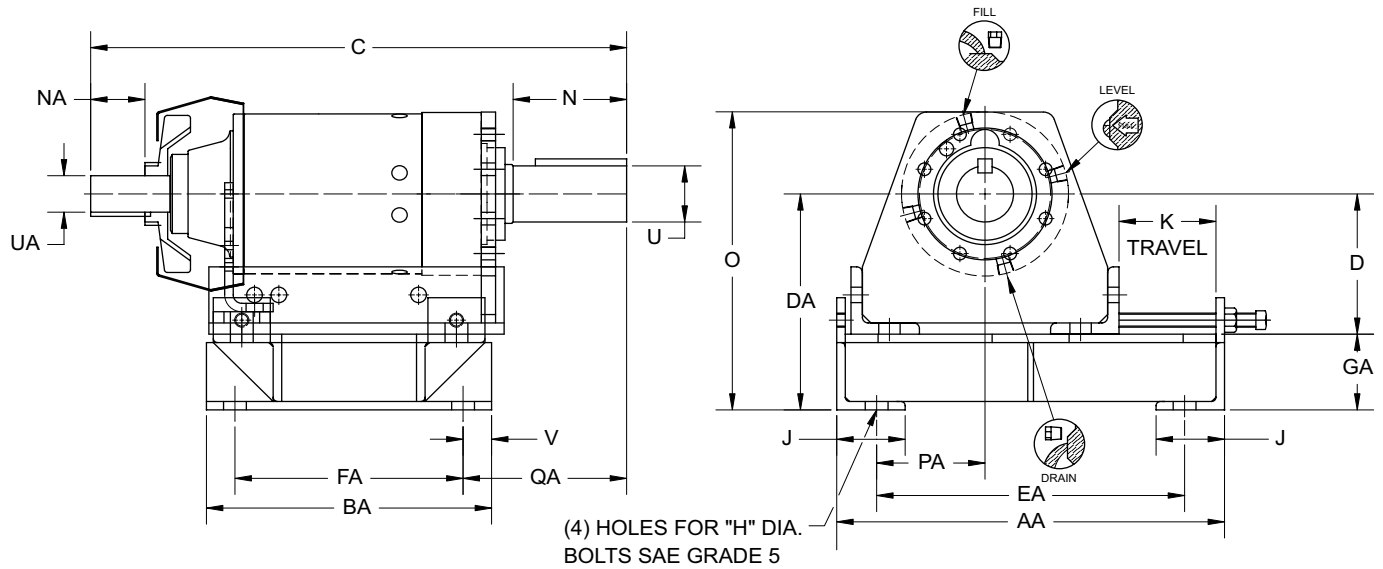

Dimensions are in Inches.

Series	AA	BA	C ①			D	DA	EA	FA	GA	H bolt	J	K	O	PA min.
			s,d	t	quad										
Mercury	17.00	12.50	19.88	22.13	24.38	6.25	9.63	13.50	10.00	3.38	7/8	3.00	4.00	13.29	4.75
Mars	17.00	12.50	21.25	23.50	25.75	6.25	9.63	13.50	10.00	3.38	7/8	3.00	4.00	13.29	4.75

Series	QA	T	V	Low Speed Shaft			High Speed Shaft				Avg. Wt. Lbs
				N	U ②	Key	NA		UA ②	Key	
							w/o fan	w/ fan			
Mercury	6.30	0.38	1.25	4.15	2.000	1/2 x 1/2 x 3	3.00	1.88	1.375	5/16 x 5/16 x 2	181
Mars	7.17	0.38	1.25	4.98	2.500	5/8 x 5/8 x 3-7/8	3.50	2.38	1.625	3/8 x 3/8 x 2-1/2	187

s = single reduction d = double reduction t = triple reduction quad = quadruple reduction

① Add 0.66 w/ Backstop

② TOLERANCES: 3.000" Diameter or less +.000/-0.001 over 3.000" Diameter +.000/-0.002

NOTE: Dimensions subject to change. Certified dimensions of ordered material furnished upon request.

Slidebase — Venus through Titan Plus

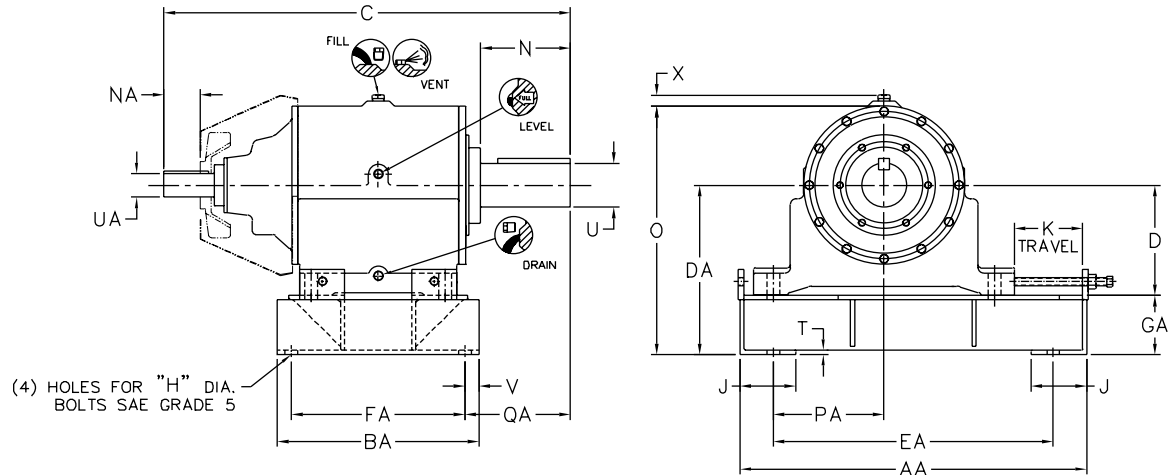

Slidebase for Jupiter Plus available - contact factory.

Dimensions are in Inches.

Series	AA	BA	C		D	DA	EA	FA	GA	H bolt	J	K	O	PA min.	QA
			s,d,t	quad											
Venus	24.00	13.50	29.73	28.52 ①	7.75	11.63	20.00	11.00	3.88	1	3.50	4.50	17.38	7.75	7.90
Atlas	24.00	13.50	30.73	29.52 ①	7.75	11.63	20.00	11.00	3.88	1	3.50	4.50	17.38	7.75	8.90
Luna	24.00	13.50	30.73	29.52 ①	7.75	11.63	20.00	11.00	3.88	1	3.50	4.50	17.38	7.75	8.90
Earth	30.00	13.50	34.08	35.71	8.75	13.25	25.00	11.00	4.50	1	4.00	5.25	20.44	9.88	10.65
Polaris	31.00	17.75	36.30	37.93	10.00	15.38	25.00	15.25	5.38	1	5.00	5.38	22.56	9.82	9.54
Delta	31.00	17.75	36.30	37.93	10.00	15.38	25.00	15.25	5.38	1	5.00	5.38	22.56	9.82	9.54
Neptune	38.00	15.00	42.79	42.69	11.25	17.00	32.00	12.00	5.75	1-1/4	5.00	6.25	26.69	12.88	16.93
Neptune Plus	38.00	15.00	42.79	42.69	11.25	17.00	32.00	12.00	5.75	1-1/4	5.00	6.25	26.69	12.88	16.93
Orion Plus	38.00	24.00	46.21	46.11	11.25	17.00	32.00	19.00	5.75	1-1/4	5.00	6.25	26.69	12.88	12.87
Saturn Plus	42.00	22.00	51.58	54.05	12.88	19.63	35.00	18.00	6.75	1-1/2	6.00	6.50	31.00	14.25	20.34
Titan Plus	42.00	22.00	51.58	54.05	12.88	19.63	35.00	18.00	6.75	1-1/2	6.00	6.50	31.00	14.25	17.54

Series	T	V	X	Low Speed Shaft				High Speed Shaft								Avg. Wt. Lbs
				N	U ②	Key	NA				UA ②					
							w/o fan		w/ fan		Key		Key			
							s,d,t	quad	s,d,t	quad	s,d,t	quad	s,d,t	quad		
Venus	0.38	1.25	1.00	5.50	2.75	5/8 x 5/8 x 4-1/8	4.25	3.50	2.88	2.50	1.875	1.625	1/2 x 1/2 x 3-3/4	3/8 x 3/8 x 2-1/2	351	
Atlas	0.38	1.25	1.00	6.50	3.25	3/4 x 3/4 x 5-1/8	4.25	3.50	2.88	2.50	1.875	1.625	1/2 x 1/2 x 3-3/4	3/8 x 3/8 x 2-1/2	381	
Luna	0.38	1.25	1.00	6.50	3.25	3/4 x 3/4 x 5-1/8	4.25	3.50	2.88	2.50	1.875	1.625	1/2 x 1/2 x 3-3/4	3/8 x 3/8 x 2-1/2	381	
Earth	0.50	1.25	1.00	7.00	3.50	7/8 x 7/8 x 5-1/2	4.50	4.25	3.25	2.88	2.125	1.875	1/2 x 1/2 x 4	1/2 x 1/2 x 3-3/4	578	
Polaris	0.38	1.25	1.00	8.00	4.00	1 x 1 x 6-1/2	4.50	4.25	3.25	2.88	2.125	1.875	1/2 x 1/2 x 4	1/2 x 1/2 x 3-3/4	860	
Delta	0.38	1.25	1.00	8.00	4.00	1 x 1 x 6-1/2	4.50	4.25	3.25	2.88	2.125	1.875	1/2 x 1/2 x 4	1/2 x 1/2 x 3-3/4	860	
Neptune	0.75	1.50	1.00	9.00	4.50	1 x 1 x 7-1/4	5.68	4.50	3.56	3.25	2.500	2.125	5/8 x 5/8 x 5-1/8	1/2 x 1/2 x 4	1141	
Neptune Plus	0.75	1.50	1.00	9.00	4.50	1 x 1 x 7-1/4	5.68	4.50	3.56	3.25	2.500	2.125	5/8 x 5/8 x 5-1/8	1/2 x 1/2 x 4	1141	
Orion Plus	0.75	2.50	1.00	10.00	5.00	1-1/4 x 1-1/4 x 9-1/4	5.68	4.50	3.56	3.25	2.500	2.125	5/8 x 5/8 x 5-1/8	1/2 x 1/2 x 4	1361	
Saturn Plus	0.75	2.00	1.00	11.05	6.50	1-1/2 x 1-1/2 x 9-1/4	6.50	5.68	4.38	3.56	3.000	2.500	3/4 x 3/4 5-7/8	5/8 x 5/8 x 5-1/8	2300	
Titan Plus	0.75	2.00	1.00	11.05	6.50	1-1/2 x 1-1/2 x 9-1/4	6.50	5.68	4.38	3.56	3.000	2.500	3/4 x 3/4 5-7/8	5/8 x 5/8 x 5-1/8	2329	

s = single reduction d = double reduction t = triple reduction quad = quadruple reduction

① Add 0.66 w/ Backstop

② TOLERANCES: 3.000" Diameter or less +.000/-0.001 over 3.000" Diameter +.000/-0.002

NOTE: Dimensions subject to change. Certified dimensions of ordered material furnished upon request.

Baseplate — Venus through Jupiter Plus

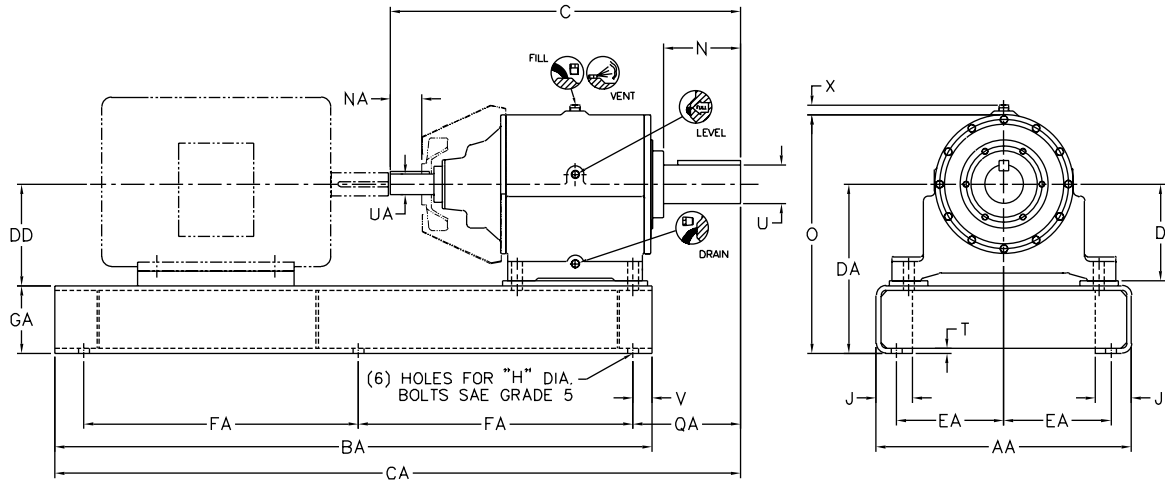

Dimensions are in inches.

Series	AA	BA	C		CA	D	DA	DD	EA	FA	GA	H bolt	J	O	QA	T
			s,d,t	quad												
Venus	20.00	54.00	29.73	28.52 ①	60.63	7.75	13.00 ②	8.13 ②	8.25	25.00	4.88	1	3.00	18.75 ②	8.63	0.25
Atlas	20.00	54.00	30.73	29.52 ①	61.63	7.75	13.00 ②	8.13 ②	8.25	25.00	4.88	1	3.00	18.75 ②	9.63	0.25
Luna	20.00	54.00	30.73	29.52 ①	61.63	7.75	13.00 ②	8.13 ②	8.25	25.00	4.88	1	3.00	18.75 ②	9.63	0.25
Earth	25.50	58.00	34.08	35.71	67.38	8.75	15.00 ③	9.13 ③	10.75	27.00	5.88	1	3.25	22.19 ③	11.38	0.38
Polaris	26.50	62.00	36.30	37.93	71.29	10.00	17.50	10.50	11.13	28.50	7.00	1	3.75	24.69	11.29	0.50
Delta	26.50	62.00	36.30	37.93	71.29	10.00	17.50	10.50	11.13	28.50	7.00	1	3.75	24.69	11.29	0.50
Neptune	32.50	62.00	42.79	42.69	78.33	11.25	19.00	11.75	13.50	28.50	7.25	1-1/4	4.25	28.69	18.83	0.50
Neptune Plus	32.50	62.00	42.79	42.69	78.33	11.25	19.00	11.75	13.50	28.50	7.25	1-1/4	4.25	28.69	18.83	0.50
Orion Plus	32.50	70.00	46.21	46.11	81.87	11.25	20.00	11.75	13.50	32.50	8.25	1-1/4	4.75	29.69	14.37	0.50
Saturn Plus	38.00	84.75	51.58	54.05	100.84	12.88	23.00	13.50	15.50	38.00	9.50	1-1/2	5.25	34.38	21.84	0.63
Titan Plus	38.00	84.75	51.58	54.05	97.54	12.88	23.00	13.50	15.50	38.00	9.50	1-1/2	5.25	34.38	18.54	0.63
Jupiter Plus	40.00	90.00	62.94	62.94	107.88	16.50	27.00	17.13	16.00	42.00	9.87	1-1/2	5.75	42.00	20.88	0.75

Series	V	X	Low Speed Shaft				High Speed Shaft						Avg. Wt. Lbs	Motor Frame Size Range ④	
			N	U ⑤	Key	NA		UA ⑤		Key					
						w/o fan		w/ fan		s,d,t	quad				
						s,d,t	quad	s,d,t	quad			s,d,t			quad
Venus	2.00	1.00	5.50	2.750	5/8 x 5/8 x 4-1/8	4.25	3.50	2.88	2.50	1.875	1.625	1/2 x 1/2 x 3-3/4	3/8 x 3/8 x 2-1/2	474	324T - 405T
Atlas	2.00	1.00	6.50	3.250	3/4 x 3/4 x 5-1/8	4.25	3.50	2.88	2.50	1.875	1.625	1/2 x 1/2 x 3-3/4	3/8 x 3/8 x 2-1/2	504	324T - 405T
Luna	2.00	1.00	6.50	3.250	3/4 x 3/4 x 5-1/8	4.25	3.50	2.88	2.50	1.875	1.625	1/2 x 1/2 x 3-3/4	3/8 x 3/8 x 2-1/2	504	324T - 405T
Earth	2.00	1.00	7.00	3.500	7/8 x 7/8 x 5-1/2	4.50	4.25	3.25	2.88	2.125	1.875	1/2 x 1/2 x 4	1/2 x 1/2 x 3-3/4	808	364T - 444T
Polaris	2.00	1.00	8.00	4.000	1 x 1 x 6-1/2	4.50	4.25	3.25	2.88	2.125	1.875	1/2 x 1/2 x 4	1/2 x 1/2 x 3-3/4	1167	364T - 444T
Delta	2.00	1.00	8.00	4.000	1 x 1 x 6-1/2	4.50	4.25	3.25	2.88	2.125	1.875	1/2 x 1/2 x 4	1/2 x 1/2 x 3-3/4	1167	364T - 444T
Neptune	2.50	1.00	9.00	4.500	1 x 1 x 7-1/4	5.68	4.50	3.56	3.25	2.500	2.125	5/8 x 5/8 x 5-1/8	1/2 x 1/2 x 4	1526	365T - 445T
Neptune Plus	2.50	1.00	9.00	4.500	1 x 1 x 7-1/4	5.68	4.50	3.56	3.25	2.500	2.125	5/8 x 5/8 x 5-1/8	1/2 x 1/2 x 4	1526	365T - 445T
Orion Plus	2.50	1.00	10.00	5.000	1 1/4 x 1-1/4 x 9-1/4	5.68	4.50	3.56	3.25	2.500	2.125	5/8 x 5/8 x 5-1/8	1/2 x 1/2 x 4	1682	365T - 445T
Saturn Plus	5.75	1.00	11.05	6.500	1 1/2 x 1-1/2 x 9-1/4	6.50	5.68	4.38	3.56	3.000	2.500	3/4 x 3/4 x 5-7/8	5/8 x 5/8 x 5-1/8	3180	404T - 449T
Titan Plus	5.75	1.00	11.05	6.500	1 1/2 x 1-1/2 x 9-1/4	6.50	5.68	4.38	3.56	3.000	2.500	3/4 x 3/4 x 5-7/8	5/8 x 5/8 x 5-1/8	3180	404T - 449T
Jupiter Plus	3.00	3.50	12.25	7.250	1 3/4 x 1-1/2 x 9-3/4	6.50	6.50	4.38	4.38	3.000	3.000	3/4 x 3/4 x 5-7/8	3/4 x 3/4 x 5-7/8	5133	404T - 449T

s = single reduction d = double reduction t = triple reduction quad = quadruple reduction

- ① Add 0.66 w/ Backstop
- ② Add 1.00 inch for 364T / 365T and 2.00 inch for 404T / 405T
- ③ Add 1.00 inch for 404T / 405T and 2.00 inch for 444T
- ④ Contact factory for motor frame sizes other than "T" frame motors.
- ⑤ TOLERANCES: 3.000" Diameter or less +.000/- .001 over 3.000" Diameter +.000/- .002

NOTE: Dimensions subject to change. Certified dimensions of ordered material furnished upon request.

Scoop Mount — Mercury & Mars

Motor Frame Size Range ②		
Series	Assy 1	Assy 2
Mercury	143T - 215T	254T - 286T
Mars	143T - 215T	254T - 324T

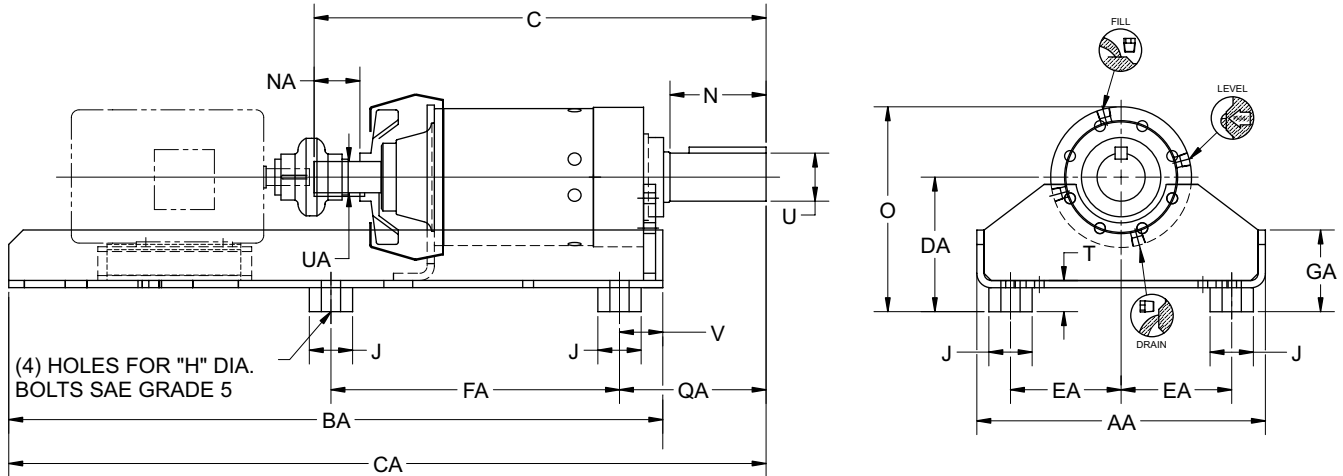

Dimensions are in Inches.

Series	AA		BA		C ①			CA		DA		EA		FA		GA	H bolt	J
	Assy 1	Assy 2	Assy 1	Assy 2	s, d	t	quad	Assy 1	Assy 2	Assy 1	Assy 2	Assy 1	Assy 2	Assy 1	Assy 2			
Mercury	15.00	21.00	34.00	42.00	19.88	22.13	24.38	38.50	46.50	7.00	9.75	5.75	8.75	15.00	20.00	4.25	7/8	2.25
Mars	15.00	21.00	34.00	42.00	21.25	23.50	25.75	39.37	47.37	7.00	9.75	5.75	8.75	15.00	20.00	4.25	7/8	2.25

Series	O		QA	T	V	Low Speed Shaft			High Speed Shaft				Avg. Wt. Lbs	
	Assy 1	Assy 2				N	U ③	Key	NA		UA ③	Key	Assy 1	Assy 2
									w/o fan	w/ fan				
Mercury	10.66	13.41	6.75	1.63	2.25	4.15	2.000	1/2 x 1/2 x 3	3.00	1.88	1.375	5/16 x 5/16 x 2	207	280
Mars	10.66	13.41	7.62	1.63	2.25	4.98	2.500	5/8 x 5/8 x 3-7/8	3.50	2.38	1.625	3/8 x 3/8 x 2-1/2	213	286

s = single reduction d = double reduction t = triple reduction quad = quadruple reduction

① Add 0.66 w/ Backstop

② Contact factory for motor frame sizes other than "T" frame motors

③ TOLERANCES: 3.000" Diameter or less +.000/- .001 over 3.000" Diameter +.000/- .002

NOTE: Dimensions subject to change. Certified dimensions of ordered material furnished upon request.

Scoop Mount — Venus through Jupiter Plus

Motor Frame Size Range ②		
Series	Assy 1	Assy 2
Venus (s,d,t,q), Atlas (s,d,t,q), Luna (s,d,t,q), Earth(q), Polaris (q), Delta (q)	143T - 256T	284T - 286T
Earth (s,d,t), Polaris (s,d,t), Delta (s,d,t), Neptune (q) Neptune Plus (q), Orion Plus(q)	145T - 256T	284T - 326T
Neptune, Neptune Plus (s,d,t), Orion Plus (s,d,t), Saturn Plus (q), Titan Plus(q)	213T - 286T	324T - 326T
Saturn Plus (s,d,t), Titan Plus(s,d,t), Jupiter Plus(s,d,t,q)	254T - 326T	364T - 365T

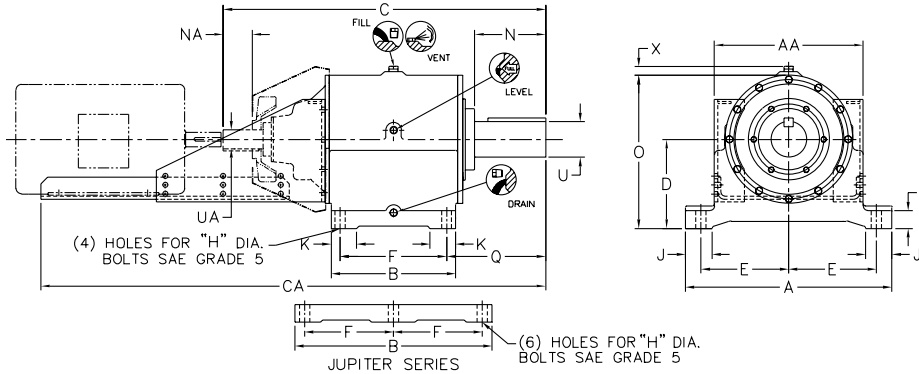

Dimensions are in inches.

Series	A	AA				B	C		CA				D
		Assy 1		Assy 2			s,d,t	quad	Assy 1		Assy 2		
		s,d,t	quad	s,d,t	quad				s,d,t	quad	s,d,t	quad	
Venus	18.00	15.25	15.25	17.00	17.00	11.75	29.73	28.52 ①	49.89	49.89	52.89	52.89	7.75
Atlas	18.00	15.25	15.25	17.00	17.00	11.75	30.73	29.52 ①	50.89	50.89	53.89	53.89	7.75
Luna	18.00	15.25	15.25	17.00	17.00	11.75	30.73	29.52 ①	50.89	50.89	53.89	53.89	7.75
Earth	23.25	16.75	15.25	19.00	17.00	11.75	34.08	35.71	54.64	55.87	59.64	58.87	8.75
Polaris	23.25	16.75	15.25	19.00	17.00	14.00	36.30	37.93	56.86	58.08	61.86	61.08	10.00
Delta	23.25	16.75	15.25	19.00	17.00	14.00	36.30	37.93	56.86	58.08	61.86	61.08	10.00
Neptune	29.25	23.00	16.75	23.00	19.00	11.69	42.79	42.69	65.63	63.25	68.63	68.25	11.25
Neptune Plus	29.25	23.00	16.75	23.00	19.00	11.69	42.79	42.69	65.63	63.25	68.63	68.25	11.25
Orion Plus	29.25	23.00	16.75	23.00	19.00	19.62	46.21	46.11	69.05	66.67	72.05	71.67	11.25
Saturn Plus	33.25	27.25	23.00	27.25	23.00	19.86	51.58	54.05	76.83	76.88	79.83	79.88	12.88
Titan Plus	33.25	27.25	23.00	27.25	23.00	19.86	51.58	54.05	76.83	76.88	79.83	79.88	12.88
Jupiter Plus	33.25	27.25	27.25	27.25	27.25	28.88	62.94	62.94	88.19	88.19	90.19	90.19	16.50

Series	E	F	G	H bolt	J	K	O	Q	X	Low Speed Shaft		
										N	U ③	Key
Venus	8.00	9.53	1.25	1	2.25	2.62	13.50	8.63	1.00	5.50	2.750	5/8 x 5/8 x 4-1/8
Atlas	8.00	9.53	1.25	1	2.25	2.62	13.50	9.63	1.00	6.50	3.250	3/4 x 3/4 x 5-1/8
Luna	8.00	9.53	1.25	1	2.25	2.62	13.50	9.63	1.00	6.50	3.250	3/4 x 3/4 x 5-1/8
Earth	9.88	9.53	2.00	1	3.13	2.62	15.94	11.38	1.00	7.00	3.500	7/8 x 7/8 x 5-1/2
Polaris	9.88	11.75	2.00	1	3.00	2.88	17.19	11.29	1.00	8.00	4.000	1 x 1 x 6-1/2
Delta	9.88	11.75	2.00	1	3.00	2.88	17.19	11.29	1.00	8.00	4.000	1 x 1 x 6-1/2
Neptune	12.88	8.19	2.75	1-1/4	4.00	4.00	20.94	18.83	1.00	9.00	4.500	1 x 1 x 7-1/4
Neptune Plus	12.88	8.19	2.75	1-1/4	4.00	4.00	20.94	18.83	1.00	9.00	4.500	1 x 1 x 7-1/4
Orion Plus	12.88	16.00	2.75	1-1/4	4.00	5.00	20.94	14.37	1.00	10.00	5.000	1-1/4 x 1-1/4 x 9-1/4
Saturn Plus	14.63	11.00	2.75	1-1/2	5.88	7.00	24.25	21.84	1.00	11.05	6.500	1-1/2 x 1-1/2 x 9-1/4
Titan Plus	14.63	16.00	2.75	1-1/2	5.88	7.00	24.25	18.54	1.00	11.05	6.500	1-1/2 x 1-1/2 x 9-1/4
Jupiter Plus	14.63	12.50	2.75	1-1/2	4.50	4.50	31.50	20.88	3.50	12.25	7.250	1-3/4 x 1-1/2 x 9-3/4

Series	High Speed Shaft								Avg. Wt. Lbs	
	NA				UA ③		Key			
	w/o fan		w/ fan		s,d,t	quad	s,d,t	quad	Assy 1	Assy 2
Venus	4.25	3.50	2.88	2.50	1.875	1.625	1/2 x 1/2 x 3-3/4	3/8 x 3/8 x 2-1/2	381	407
Atlas	4.25	3.50	2.88	2.50	1.875	1.625	1/2 x 1/2 x 3-3/4	3/8 x 3/8 x 2-1/2	411	437
Luna	4.25	3.50	2.88	2.50	1.875	1.625	1/2 x 1/2 x 3-3/4	3/8 x 3/8 x 2-1/2	411	437
Earth	4.50	4.25	3.25	2.88	2.125	1.875	1/2 x 1/2 x 4	1/2 x 1/2 x 3-3/4	577	620
Polaris	4.50	4.25	3.25	2.88	2.125	1.875	1/2 x 1/2 x 4	1/2 x 1/2 x 3-3/4	836	858
Delta	4.50	4.25	3.25	2.88	2.125	1.875	1/2 x 1/2 x 4	1/2 x 1/2 x 3-3/4	836	858
Neptune	5.68	4.50	3.56	3.25	2.500	2.125	5/8 x 5/8 x 5-1/8	1/2 x 1/2 x 4	1094	1095
Neptune Plus	5.68	4.50	3.56	3.25	2.500	2.125	5/8 x 5/8 x 5-1/8	1/2 x 1/2 x 4	1094	1095
Orion Plus	5.68	4.50	3.56	3.25	2.500	2.125	5/8 x 5/8 x 5-1/8	1/2 x 1/2 x 4	1316	1318
Saturn Plus	6.50	5.68	4.38	3.56	3.000	2.500	3/4 x 3/4 x 5-7/8	5/8 x 5/8 x 5-1/8	2233	2267
Titan Plus	6.50	5.68	4.38	3.56	3.000	2.500	3/4 x 3/4 x 5-7/8	5/8 x 5/8 x 5-1/8	2233	2267
Jupiter Plus	6.50	6.50	4.38	4.38	3.000	3.000	3/4 x 3/4 x 5-7/8	3/4 x 3/4 x 5-7/8	3703	3737

s = single reduction d = double reduction t = triple reduction quad (q) = quadruple reduction
 ① Add 0.66 w/ Backstop ② Contact factory for motor frame sizes other than "T" frame motors
 ③ TOLERANCES: 3.000" Diameter or less +.000/- .001 over 3.000" Diameter +.000/- .002

NOTE: DIMENSIONS subject to change. Certified dimensions of ordered material furnished upon request.

Scoop Mount with Slidebase — Mercury & Mars

Motor Frame Size Range ②		
Series	Assy 1	Assy 2
Mercury	143T - 215T	254T - 286T
Mars	143T - 215T	254T - 324T

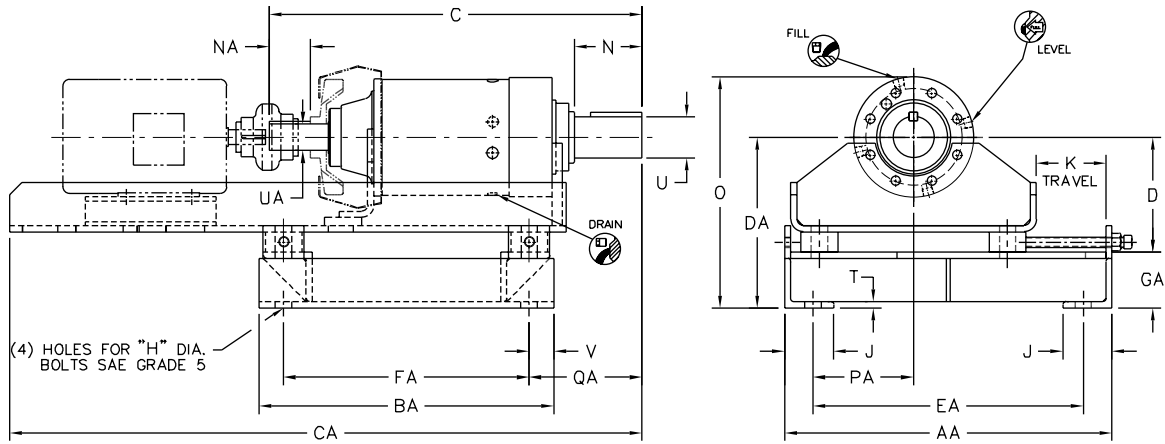

Dimensions are in Inches.

Series	AA		BA		C ①			CA		D		DA		EA		FA		GA	H bolt	J
	Assy1	Assy2	Assy1	Assy2	s,d	t	quad	Assy1	Assy2	Assy1	Assy2	Assy1	Assy2	Assy1	Assy2	Assy1	Assy2			
Mercury	20.00	26.00	18.00	23.00	19.88	22.13	24.38	38.50	46.50	7.00	9.75	10.38	13.13	16.50	22.50	15.00	20.00	3.38	7/8	3.00
Mars	20.00	26.00	18.00	23.00	21.25	23.50	25.75	39.37	47.37	7.00	9.75	10.38	13.13	16.50	22.50	15.00	20.00	3.38	7/8	3.00

Series	K	O		PA		QA	T	V	Low Speed Shaft			High Speed Shaft				Avg. Wt.Lbs	
									N	U ③	Key	NA		Key			
		w/o fan	w/ fan	UA ③													
Mercury	4.25	14.04	16.79	6.13	9.13	6.75	0.38	1.50	4.15	2.000	1/2 x 1/2 x 3	3.00	1.88	1.375	5/16 x 5/16 x 2	255	341
Mars	4.25	14.04	16.79	6.13	9.13	7.62	0.38	1.50	4.98	2.500	5/8 x 5/8 x 3-7/8	3.50	2.38	1.625	3/8 x 3/8 x 2-1/2	261	347

s = single reduction d = double reduction t = triple reduction quad = quadruple reduction

① Add 0.66 w/ Backstop

② Contact factory for motor frame sizes other than "T" frame motors

③ TOLERANCES: 3.000" Diameter or less +.000/- .001 over 3.000" Diameter +.000/- .002

NOTE: Dimensions subject to change. Certified dimensions of ordered material furnished upon request.

Scoop Mount with Slidebase — Venus through Titan Plus

Motor Frame Size Range ②		
Series	Assy 1	Assy 2
Venus (s,d,t,q), Atlas (s,d,t,q), Luna (s,d,t,q), Earth (q), Polaris (q), Delta (q)	143T - 256T	284T - 286T
Earth (s,d,t), Polaris (s,d,t), Delta (s,d,t), Neptune (q), Neptune Plus (q), Orion Plus (q)	145T - 256T	284T - 326T
Neptune (s,d,t), Neptune Plus (s,d,t), Orion Plus (s,d,t), Saturn Plus (q), Titan Plus (q)	213T - 286T	324T - 326T
Saturn Plus (s,d,t), Titan Plus (s,d,t)	254T - 326T	364T - 365T

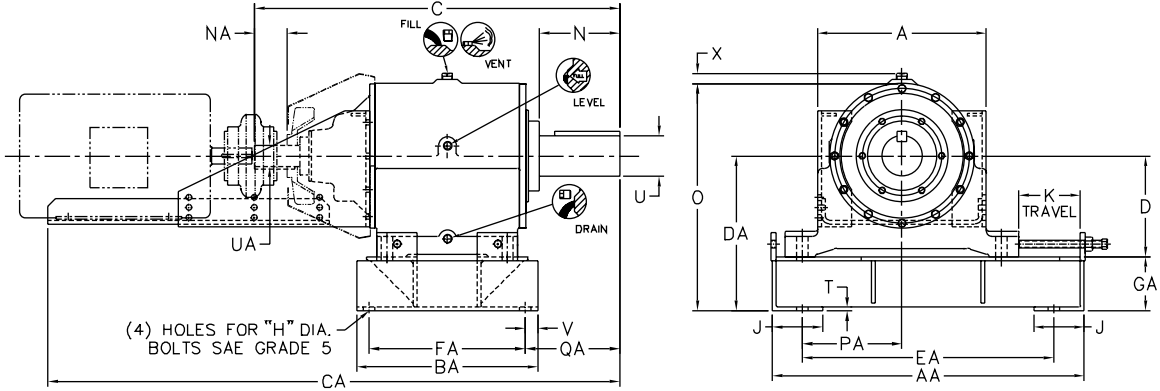

Scoop Mount with Slidebase for Jupiter Plus available - contact factory.

Dimensions are in inches.

Series	A				AA	BA	C		CA				D	DA
	Assy 1		Assy 2				s,d,t	quad	Assy 1		Assy 2			
	s,d,t	quad	s,d,t	quad			s,d,t	quad	s,d,t	quad	s,d,t	quad		
Venus	15.25	15.25	17.00	17.00	24.00	13.50	29.73	28.52 ①	49.89	49.89	52.89	52.89	7.75	11.63
Atlas	15.25	15.25	17.00	17.00	24.00	13.50	30.73	29.52 ①	50.89	50.89	53.89	53.89	7.75	11.63
Luna	15.25	15.25	17.00	17.00	24.00	13.50	30.73	29.52 ①	50.89	50.89	53.89	53.89	7.75	11.63
Earth	16.75	15.25	19.00	17.00	30.00	13.50	34.08	35.71	54.64	55.87	59.64	58.87	8.75	13.25
Polaris	16.75	15.25	19.00	17.00	31.00	17.75	36.30	37.93	56.86	58.08	61.86	61.08	10.00	15.38
Delta	16.75	15.25	19.00	17.00	31.00	17.75	36.30	37.93	56.86	58.08	61.86	61.08	10.00	15.38
Neptune	23.00	16.75	23.00	19.00	38.00	15.00	42.79	42.69	65.63	63.25	68.63	68.25	11.25	17.00
Neptune Plus	23.00	16.75	23.00	19.00	38.00	15.00	42.79	42.69	65.63	63.25	68.63	68.25	11.25	17.00
Orion Plus	23.00	16.75	23.00	19.00	38.00	24.00	46.21	46.11	69.05	66.67	72.05	71.67	11.25	17.00
Saturn Plus	27.25	23.00	27.25	23.00	42.00	22.00	51.58	54.05	76.83	76.88	79.83	79.88	12.88	19.63
Titan Plus	27.25	23.00	27.25	23.00	42.00	22.00	51.58	54.05	76.83	76.88	79.83	79.88	12.88	19.63

Series	EA	FA	GA	H bolt	J	K	O	PA min.	QA	T	V	X
Atlas	20.00	11.00	3.88	1	3.50	4.50	17.38	7.75	8.90	0.38	1.25	1.00
Luna	20.00	11.00	3.88	1	3.50	4.50	17.38	7.75	8.90	0.38	1.25	1.00
Earth	25.00	11.00	4.50	1	4.00	5.25	20.44	9.88	10.65	0.50	1.25	1.00
Polaris	25.00	15.25	5.38	1	5.00	5.38	22.56	9.82	9.54	0.38	1.25	1.00
Delta	25.00	15.25	5.38	1	5.00	5.38	22.56	9.82	9.54	0.38	1.25	1.00
Neptune	32.00	12.00	5.75	1-1/4	5.00	6.25	26.69	12.88	16.93	0.75	1.50	1.00
Neptune Plus	32.00	12.00	5.75	1-1/4	5.00	6.25	26.69	12.88	16.93	0.75	1.50	1.00
Orion Plus	32.00	19.00	5.75	1-1/4	5.00	6.25	26.69	12.88	12.87	0.75	2.50	1.00
Saturn Plus	35.00	18.00	6.75	1-1/2	6.00	6.50	31.00	14.25	20.34	0.75	2.00	1.00
Titan Plus	35.00	18.00	6.75	1-1/2	6.00	6.50	31.00	14.25	17.54	0.75	2.00	1.00

Series	Low Speed Shaft			High Speed Shaft								Avg. Wt. Lbs	
	N	U ③	Key	NA				UA ③		Key		Assy 1	Assy 2
				w/o fan		w/ fan		s,d,t	quad	s,d,t	quad		
			s,d,t	quad	s,d,t	quad	s,d,t	quad	s,d,t	quad			
Venus	5.50	2.750	5/8 x 5/8 x 4-1/8	4.25	3.50	2.88	2.50	1.875	1.625	1/2 x 1/2 x 3-3/4	3/8 x 3/8 x 2-1/2	437	463
Atlas	6.50	3.250	3/4 x 3/4 x 5-1/8	4.25	3.50	2.88	2.50	1.875	1.625	1/2 x 1/2 x 3-3/4	3/8 x 3/8 x 2-1/2	467	493
Luna	6.50	3.250	3/4 x 3/4 x 5-1/8	4.25	3.50	2.88	2.50	1.875	1.625	1/2 x 1/2 x 3-3/4	3/8 x 3/8 x 2-1/2	467	493
Earth	7.00	3.500	7/8 x 7/8 x 5-1/2	4.50	4.25	3.25	2.88	2.125	1.875	1/2 x 1/2 x 4	1/2 x 1/2 x 3-3/4	674	717
Polaris	8.00	4.000	1 x 1 x 6-1/2	4.50	4.25	3.25	2.88	2.125	1.875	1/2 x 1/2 x 4	1/2 x 1/2 x 3-3/4	993	1015
Delta	8.00	4.000	1 x 1 x 6-1/2	4.50	4.25	3.25	2.88	2.125	1.875	1/2 x 1/2 x 4	1/2 x 1/2 x 3-3/4	993	1015
Neptune	9.00	4.500	1 x 1 x 7-1/4	5.68	4.50	3.56	3.25	2.500	2.125	5/8 x 5/8 x 5-1/8	1/2 x 1/2 x 4	1312	1313
Neptune Plus	9.00	4.500	1 x 1 x 7-1/4	5.68	4.50	3.56	3.25	2.500	2.125	5/8 x 5/8 x 5-1/8	1/2 x 1/2 x 4	1312	1313
Orion Plus	10.00	5.000	1-1/4 x 1-1/4 x 9-1/4	5.68	4.50	3.56	3.25	2.500	2.125	5/8 x 5/8 x 5-1/8	1/2 x 1/2 x 4	1531	1533
Saturn Plus	11.05	6.500	1-1/2 x 1-1/2 x 9-1/4	6.50	5.68	4.38	3.56	3.000	2.500	3/4 x 3/4 x 5-7/8	5/8 x 5/8 x 5-1/8	2562	2596
Titan Plus	11.05	6.500	1-1/2 x 1-1/2 x 9-1/4	6.50	5.68	4.38	3.56	3.000	2.500	3/4 x 3/4 x 5-7/8	5/8 x 5/8 x 5-1/8	2562	2596

s = single reduction d = double reduction t = triple reduction quad (q) = quadruple reduction
 ① Add 0.66 w/ Backstop ② Contact factory for motor frame sizes other than "T" frame motors
 ③ TOLERANCES: 3.000" Diameter or less +.000/-0.001 over 3.000" Diameter +.000/-0.002

NOTE: DIMENSIONS SUBJECT TO CHANGE. CERTIFIED DIMENSIONS OF ORDERED MATERIAL FURNISHED UPON REQUEST.

Baseplate with Slidebase — Venus through Titan Plus

Motor Frame Size Range ④	
Series	Motor Frame
Venus	324T - 405T
Atlas	324T - 405T
Luna	324T - 405T
Earth	364T - 444T
Polaris	364T - 444T
Delta	364T - 444T
Neptune	364T - 445T
Neptune Plus	364T - 445T
Orion Plus	364T - 445T
Saturn Plus	404T - 449T
Titan Plus	404T - 449T

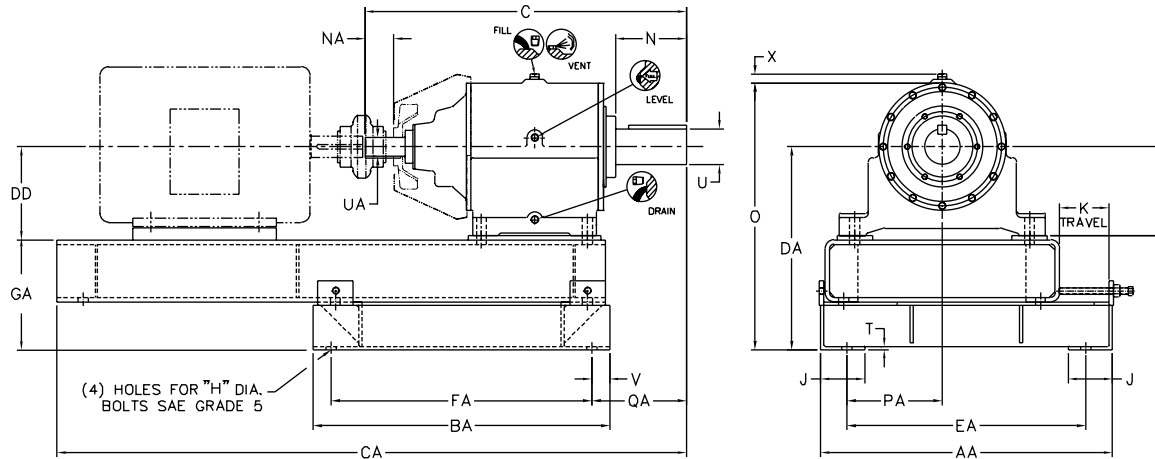

Baseplate with Slidebase for Jupiter Plus available - contact factory.

Dimensions are in Inches.

Series	AA	BA	C		CA	D	DA	DD	EA	FA	GA	H bolt	J	K	O	PA min.	QA
			s,d,t	quad													
Venus	26.00	29.00	29.73	28.52 ①	60.63	7.75	16.88 ②	8.13 ②	22.00	25.00	8.75	1	3.50	5.25	22.63 ②	8.38	8.63
Atlas	26.00	29.00	30.73	29.52 ①	61.63	7.75	16.88 ②	8.13 ②	22.00	25.00	8.75	1	3.50	5.25	22.63 ②	8.38	9.63
Luna	26.00	29.00	30.73	29.52 ①	61.63	7.75	16.88 ②	8.13 ②	22.00	25.00	8.75	1	3.50	5.25	22.63 ②	8.38	9.63
Earth	32.00	31.00	34.08	35.71	67.38	8.75	19.50 ③	9.13 ③	27.00	27.00	10.38	1	4.00	5.50	26.69 ③	10.75	11.38
Polaris	33.00	33.50	36.30	37.93	71.16	10.00	22.88	10.50	27.00	29.50	12.38	1	5.00	5.63	30.06	10.69	10.79
Delta	33.00	33.50	36.30	37.93	71.16	10.00	22.88	10.50	27.00	29.50	12.38	1	5.00	5.63	30.06	10.69	10.79
Neptune	41.00	33.50	42.79	42.69	78.33	11.25	24.75	11.75	35.00	28.50	13.00	1-1/4	5.00	7.00	34.44	14.00	18.83
Neptune Plus	41.00	33.50	42.79	42.69	78.33	11.25	24.75	11.75	35.00	28.50	13.00	1-1/4	5.00	7.00	34.44	14.00	18.83
Orion Plus	41.00	37.50	46.21	46.11	81.87	11.25	25.75	11.75	35.00	32.50	14.00	1-1/4	5.00	7.00	35.44	14.00	14.37
Saturn Plus	47.00	44.00	51.58	54.05	100.84	12.88	29.75	13.50	40.00	38.00	15.25	1-1/2	6.00	7.50	41.13	16.25	21.84
Titan Plus	47.00	44.00	51.58	54.05	97.54	12.88	29.75	13.50	40.00	38.00	16.25	1-1/2	6.00	7.50	41.13	16.25	18.54

Series	T	V	X	Low Speed Shaft				High Speed Shaft						Avg. Wt. Lbs	
				N	U ⑤	Key	NA		UA ⑥		Key				
							w/o fan		w/ fan		s,d,t		quad		
							s,d,t	quad	s,d,t	quad	s,d,t	quad	s,d,t		quad
Venus	0.38	2.00	1.00	5.50	2.750	5/8 x 5/8 x 4-1/8	4.25	3.50	2.88	2.50	1.875	1.625	1/2 x 1/2 x 3-3/4	3/8 x 3/8 x 2-1/2	555
Atlas	0.38	2.00	1.00	6.50	3.250	3/4 x 3/4 x 5-1/8	4.25	3.50	2.88	2.50	1.875	1.625	1/2 x 1/2 x 3-3/4	3/8 x 3/8 x 2-1/2	585
Luna	0.38	2.00	1.00	6.50	3.250	3/4 x 3/4 x 5-1/8	4.25	3.50	2.88	2.50	1.875	1.625	1/2 x 1/2 x 3-3/4	3/8 x 3/8 x 2-1/2	585
Earth	0.50	2.00	1.00	7.00	3.500	7/8 x 7/8 x 5-1/2	4.50	4.25	3.25	2.88	2.125	1.875	1/2 x 1/2 x 4	1/2 x 1/2 x 3-3/4	947
Polaris	0.38	2.00	1.00	8.00	4.000	1 x 1 x 6-1/2	4.50	4.25	3.25	2.88	2.125	1.875	1/2 x 1/2 x 4	1/2 x 1/2 x 3-3/4	1389
Delta	0.38	2.00	1.00	8.00	4.000	1 x 1 x 6-1/2	4.50	4.25	3.25	2.88	2.125	1.875	1/2 x 1/2 x 4	1/2 x 1/2 x 3-3/4	1389
Neptune	0.75	2.50	1.00	9.00	4.500	1 x 1 x 7-1/4	5.68	4.50	3.56	3.25	2.500	2.125	5/8 x 5/8 x 5-1/8	1/2 x 1/2 x 4	1830
Neptune Plus	0.75	2.50	1.00	9.00	4.500	1 x 1 x 7-1/4	5.68	4.50	3.56	3.25	2.500	2.125	5/8 x 5/8 x 5-1/8	1/2 x 1/2 x 4	1830
Orion Plus	0.75	2.50	1.00	10.00	5.000	1-1/4 x 1-1/4 x 9-1/4	5.68	4.50	3.56	3.25	2.500	2.125	5/8 x 5/8 x 5-1/8	1/2 x 1/2 x 4	2008
Saturn Plus	0.75	3.00	1.00	11.05	6.500	1-1/2 x 1-1/2 x 9-1/4	6.50	5.68	4.38	3.56	3.000	2.500	3/4 x 3/4 x 5-7/8	5/8 x 5/8 x 5-1/8	3632
Titan Plus	0.75	3.00	1.00	11.05	6.500	1-1/2 x 1-1/2 x 9-1/4	6.50	5.68	4.38	3.56	3.000	2.500	3/4 x 3/4 x 5-7/8	5/8 x 5/8 x 5-1/8	3632

s = single reduction d = double reduction t = triple reduction quad = quadruple reduction

① Add 0.66 w/ Backstop

② Add 1.00 inch for 364T / 365T and 2.00 inch for 404T / 405T

③ Add 1.00 inch for 404T / 405T and 2.00 inch for 444T

④ Contact factory for motor frame sizes other than "T" frame motors.

⑤ TOLERANCES: 3.000" Diameter or less +.000/-.001 over 3.000" Diameter +.000/-.002

NOTE: Dimensions subject to change. Certified dimensions of ordered material furnished upon request.

C-face Reducer — Mercury & Mars

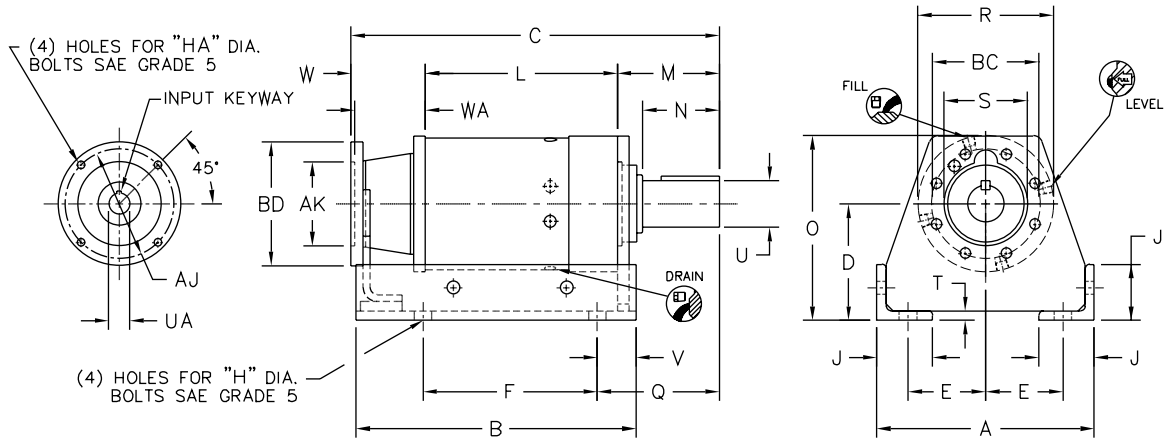

Dimensions are in inches.

Series	A	B		BC	D	E	F	H bolt	J	L			M	O	Q
		s, d, t	quad							s, d	t	quad			
Mercury	11.75	12.94	15.13	5.750	6.25	4.19	9.41	7/8	3.00	8.13	10.38	12.63	5.50	9.91	6.59
Mars	11.75	12.94	15.13	5.750	6.25	4.19	9.41	7/8	3.00	8.13	10.38	12.63	6.37	9.91	7.46

Series	R max.	S max.	T	V	Low Speed Shaft			Avg. Wt. Lbs	
	N	U ①			Key				
Mercury	7.32	4.50	0.50	2.09	4.15	2.000	1/2 x 1/2 x 3		149
Mars	7.32	4.50	0.50	2.09	4.98	2.500	5/8 x 5/8 x 3-7/8		155

Motor Frame	AJ	AK	BD	HA	UA	W	WA	C					
				bolt				Mercury			Mars		
								s, d	t	quad	s, d	t	quad
56C	5.875	4.50	6.63	3/8	5/8	4.00	—	17.63	19.88	22.13	18.50	20.75	23.00
143TC, 145TC, 182C, 184C	5.875	4.50	6.63	3/8	7/8	4.00	—	17.63	19.88	22.13	18.50	20.75	23.00
182TC, 184TC, 213C, 215C	7.250	8.50	9.00	1/2	1-1/8	4.69	4.50	19.32	20.57	22.82	19.19	21.44	23.69
213TC, 215TC	7.250	8.50	9.00	1/2	1-3/8	4.69	4.50	19.32	20.57	22.82	19.19	21.44	23.69

s = single reduction d = double reduction t = triple reduction quad = quadruple reduction

① TOLERANCES: 3.000" Diameter or less +.000/-0.001 over 3.000" Diameter +.000/-0.002

NOTE: Dimensions subject to change. Certified dimensions of ordered material furnished upon request.

C-face Reducer — Venus through Orion Plus

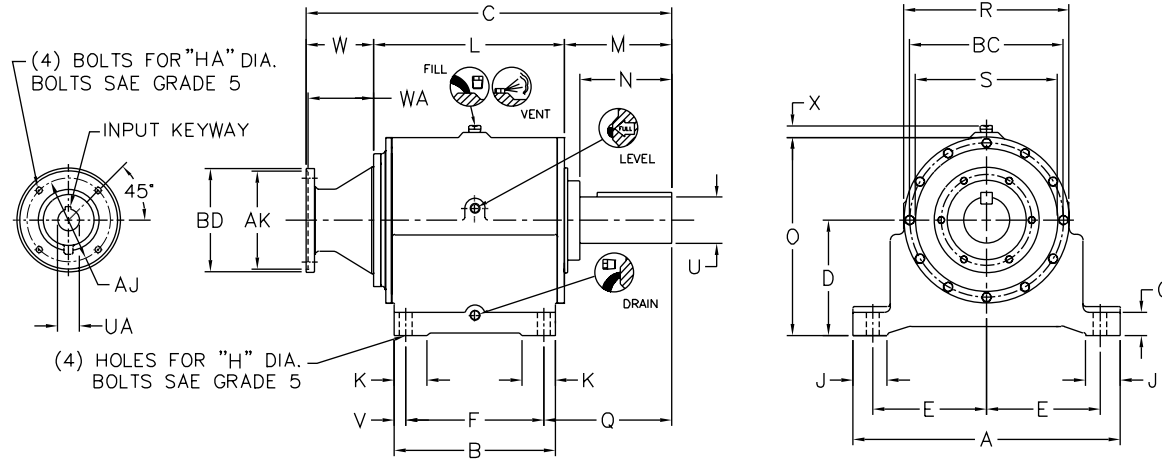

Dimensions are in Inches.

Series	A	B	BC	D	E	F	G	H bolt	J	K	L		M
											s,d,t ^②	quad	
Venus	18.00	11.75	10.500	7.75	8.00	9.53	1.25	1	2.25	2.62	13.19	15.63	6.76
Atlas	18.00	11.75	10.500	7.75	8.00	9.53	1.25	1	2.25	2.62	13.19	15.63	7.76
Luna	18.00	11.75	10.500	7.75	8.00	9.53	1.25	1	2.25	2.62	13.19	15.63	7.76
Earth	23.25	11.75	13.375	8.75	9.88	9.53	2.00	1	3.13	2.62	14.12	16.34	9.58
Polaris	23.25	14.00	13.375	10.00	9.88	11.75	2.00	1	3.00	2.88	16.59	18.82	9.33
Delta	23.25	14.00	13.375	10.00	9.88	11.75	2.00	1	3.00	2.88	16.59	18.82	9.33
Neptune	29.25	11.69	18.250	11.25	12.88	8.19	2.75	1-1/4	4.00	4.00	—	16.12	16.20
Neptune Plus	29.25	11.69	18.250	11.25	12.88	8.19	2.75	1-1/4	4.00	4.00	—	16.12	16.20
Orion Plus	29.25	19.62	18.250	11.25	12.88	16.00	2.75	1-1/4	4.00	5.00	—	23.92	11.81

Series	O	Q	R	S max.	V	X	Low Speed Shaft			Avg. Wt. Lbs
							N	U ^①	Key	
Venus	13.50	8.63	11.50	7.28	1.11	1.00	5.50	2.750	5/8 x 5/8 x 4-1/8	295
Atlas	13.50	9.63	11.50	7.28	1.11	1.00	6.50	3.250	3/4 x 3/4 x 5-1/8	325
Luna	13.50	9.63	11.50	7.28	1.11	1.00	6.50	3.250	3/4 x 3/4 x 5-1/8	325
Earth	15.94	11.38	14.38	11.90	1.11	1.00	7.00	3.500	7/8 x 7/8 x 5-1/2	491
Polaris	17.19	11.29	14.38	9.14	1.13	1.00	8.00	4.000	1 x 1 x 6-1/2	702
Delta	17.19	11.29	14.38	9.14	1.13	1.00	8.00	4.000	1 x 1 x 6-1/2	702
Neptune	20.94	19.00	19.38	16.52	1.75	1.00	9.00	4.500	1 x 1 x 7-1/4	923
Neptune Plus	20.94	19.00	19.38	16.52	1.75	1.00	9.00	4.500	1 x 1 x 7-1/4	923
Orion Plus	20.94	14.37	19.38	13.00	1.81	1.00	10.00	5.000	1-1/4 x 1-1/4 x 9-1/4	1146

s = single reduction d = double reduction t = triple reduction quad = quadruple reduction

① TOLERANCES: 3.000" Diameter or less +.000/-0.001 over 3.000" Diameter +.000/-0.002

② Neptune & Orion are not available in single, double, or triple reductions.

NOTE: Dimensions subject to change. Certified dimensions of ordered material furnished upon request.

C-face Reducer — Venus through Orion Plus Continued

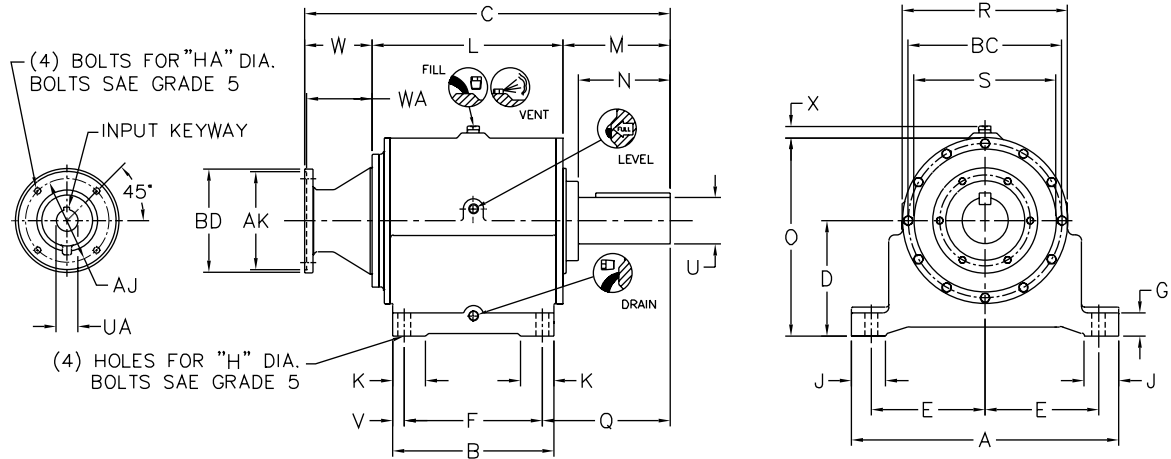

Dimensions are in inches.

Motor Frame	AJ	AK	BD	HA bolt	UA	W				WA			
						s,d,t ①	quad			s,d,t ①	quad		
							Venus, Atlas & Luna	Earth, Polaris, & Delta	Neptune, Neptune Plus & Orion Plus		Venus, Atlas & Luna	Earth, Polaris, & Delta	Neptune, Neptune Plus & Orion Plus
56C	5.875	4.50	6.63	3/8	5/8	—	3.38	—	—	—	3.19	—	—
143TC, 145TC, 182C, 184C	5.875	4.50	6.63	3/8	7/8	4.86	3.38	4.86	4.86	4.67	3.19	4.67	4.67
182TC, 184TC, 213C, 215C	7.250	8.50	9.00	1/2	1-1/8	5.91	4.06	5.91	5.91	5.72	3.88	5.72	5.72
210TC	7.250	8.50	9.00	1/2	1-3/8	5.91	4.06	5.91	5.91	5.72	3.88	5.72	5.72
250TC	7.250	8.50	9.00	1/2	1-5/8	5.91	—	5.91	5.91	5.72	—	5.72	5.72
280TC	9.000	10.50	11.00	1/2	1-7/8	6.06	—	6.06	6.06	5.87	—	5.87	5.87

Motor Frame	C												
	Venus		Atlas & Luna		Earth		Polaris & Delta		Neptune & Neptune Plus		Orion Plus		
	s,d,t	quad	s,d,t	quad	s,d,t	quad	s,d,t	quad	s,d,t	quad	s,d,t	quad	
56C	—	25.77	—	26.77	—	—	—	—	—	—	—	—	—
143TC, 145TC, 182C, 184C	24.81	25.77	25.81	26.77	28.56	30.78	30.78	33.01	—	37.18	—	40.60	
182TC, 184TC, 213C, 215C	25.86	26.45	26.86	27.45	29.61	31.83	31.83	34.06	—	38.23	—	41.64	
210TC	25.86	26.45	26.86	27.45	29.61	31.83	31.83	34.06	—	38.23	—	41.64	
250TC	25.86	—	26.86	—	29.61	31.83	31.83	34.06	—	38.23	—	41.64	
280TC	26.01	—	27.01	—	29.76	31.98	31.98	34.21	—	38.38	—	41.79	

s = single reduction d = double reduction t = triple reduction quad = quadruple reduction

① Neptune & Orion are not available in single, double, or triple reductions.

NOTE: Dimensions subject to change. Certified dimensions of ordered material furnished upon request.

Torque Ratings (lb-in) at 1750 RPM

TABLE 12

Low Speed Shaft Torque Ratings at 1750 RPM Input

Reduction	Nominal Ratio	Mercury	Mars	Venus	Atlas	Luna	Earth	Polaris	Delta	Neptune	Neptune Plus	Orion Plus	Saturn Plus	Titan Plus	Jupiter Plus
Single	3.53	4000	8000	16000			42000	54000		75000	117000	117000			
	4.39	4000	7000	16000	28000	40000	44000	52000		80000	142000	144000			
	6.12	3000	7000	17000	30000	37000	46000			85000	150000				
Double	9.30		10000		26000		50000	64000		110000					
	11.02	5000	10000	21000	36000	50000	60000	80000	127000	110000	196000	241000	250000	405000	
	13.85	6000	12000	22000	38000	50000	64000	85000	131000	115000	209000	250000	260000	432000	555000
	17.21	6000	13000	21000	38000	47000	64000	85000	138000	120000	199000	287000	320000	449000	
	20.41	6000	12000	23000	38000	41000	70000	100000	121000	130000	214000	241000	280000	477000	610000
	24.00	7000	14000	22000	38000	48000	66000	90000	139000	135000	201000	299000	350000	496000	522000
	31.63	6000	13000	19000	32000	39000	56000			120000	162000		360000	512000	
43.78	5000	10000													
Triple	31.63				38000		66000	80000		150000					
	36.56	7000	15000	23000	41000	51000	70000	110000	150000	150000	184000	274000	360000	580000	
	43.78	7000	16000	24000	41000	51000	72000	115000	150000	150000	184000	311000	380000	589000	794000
	54.45	8000	17000	24000	42000	51000	72000	120000	151000	150000	219000	313000	400000	593000	800000
	64.42	8000	17000	24000	42000	51000	72000	120000	135000	155000	184000	274000	420000	594000	807000
	69.63	7000	17000	22000	39000	49000	68000	105000	142000	145000	206000	315000	400000	543000	811000
	80.01	8000	17000	24000	42000	51000	74000	120000	152000	160000	221000	315000	430000	598000	703000
	91.41	8000	17000		38000		54000			130000	211000	260000	450000	599000	706000
	99.38	7000	15000	23000	40000	49000	70000	105000	143000	145000	208000	316000	420000	550000	819000
	111.5	8000	17000	24000	42000	43000	74000	120000	127000	160000	223000	254000	440000	536000	712000
	121.4														825000
	138.5	7000	15000	23000	39000	49000	70000	110000	144000	150000	210000	315000	420000	557000	
	159.8	8000	17000												
193.1	7000	15000	20000	33000	40000	60000			130000	172000				564000	
265.4	5000	10000													
Quadruple	121.4	7000	17000	24000	38000	51000	74000	120000	153000	160000	223000	274000	440000	605000	
	138.5			24000	43000	51000									831000
	159.8			24000	43000	51000	74000	120000	154000	160000	224000	316000	440000	608000	724000
	193.1						76000	120000	154000	160000	226000	316000	440000	611000	
	206.2	8000	17000	24000	43000	51000	76000	120000	154000	160000	226000	274000	440000	613000	730000
	238.2	8000	17000	24000	43000	51000	76000	120000	154000	160000	227000	316000	440000	615000	849000
	265.4	7000	17000	24000	43000	51000	76000	120000	154000	160000	227000	316000	440000	617000	852000
	295.7	8000	17000	24000	43000	51000	72000	115000	147000	150000	213000	316000	420000	573000	856000
	330.1	8000	18000	23000	40000	50000	76000	120000	154000	160000	228000	316000	440000	620000	858000
	369.8	8000	18000	24000	43000	51000	76000	120000	140000	160000	229000	274000	440000	622000	863000
	412.1	8000	18000	24000	43000	51000	72000	115000	148000	155000	215000	316000	430000	580000	865000
	459.0	7000	16000	23000	40000	50000	76000	120000	154000	160000	230000	316000	440000	626000	869000
	532.5	8000	18000	24000	43000	51000	72000	115000	149000	155000	217000	316000	430000	587000	874000
	617.9	8000	18000	23000	40000	51000	76000	120000	133000	160000	232000	268000	440000	570000	761000
	660.6	7000	16000												763000
	741.2	8000	18000	24000	43000	45000	72000	115000	150000	155000	219000	316000	430000	594000	
	900.3	7000	16000	23000	40000	51000									
1057	8000	18000	20000	33000	42000	60000			130000	183000					
1255	7000	16000	20000	33000	42000										
1785	6000	10000													
Quintuple	660.6						76000	120000	154000	160000	232000	274000	440000	632000	
	741.2														885000
	900.3						76000	115000	154000	160000	234000	316000	440000	638000	892000
	1057							120000	154000			316000	440000	640000	899000
	1255						76000	115000	154000	160000	236000	274000	440000	643000	903000
1785						72000	115000	149000	160000	238000	316000	440000	591000	905000	

Power Ratings (HP) at 1750 RPM

TABLE 13

Mechanical Input HP Ratings 1750 RPM Input

Reduction	Nominal Ratio	Mercury	Mars	Venus	Atlas	Luna	Earth	Polaris	Delta	Neptune	Neptune Plus	Orion Plus	Saturn Plus	Titan Plus	Jupiter Plus
Single	3.53	30.4	60.8	137			360	463		643.34	1004	1004			
	4.39	24.4	42.7	111	194	276.2	305	360		554.33	983	997			
	6.12	13.1	30.7	84.3	149	183.2	228			421.72	744				
Double	9.30		31.0		80.4		155	198		340.00					
	11.02	14.3	28.5	55.7	95.4	133	159	212	337	291.56	520	639	663	1074	
	13.85	12.5	24.9	47.0	81.3	107	137	182	280	245.90	447	535	556	924	1266
	17.21	10.0	21.7	36.2	65.6	81.1	110	147	238	207.03	343	495	552	775	
	20.41	8.05	16.1	35.3	58.3	62.9	107	153	186	199.33	328	370	429	731	934
	24.00	8.39	16.8	27.2	47.0	59.4	81.7	111	172	167.01	249	370	433	614	618
	31.63	5.78	12.5	17.7	28.4	34.6	49.7			106.41	144		345	490	
	43.78	3.46	6.91												
Triple	31.63				36.29		63.0	76.4		143.25					
	36.56	5.46	11.7	18.8	33.6	41.8	57.3	90.1	122.9	122.88	151	224	295	475	
	43.78	4.66	10.7	15.9	27.1	33.7	47.6	76.0	99.1	99.13	122	206	251	389	560
	54.45	4.55	9.66	12.8	22.4	27.2	38.4	64.0	80.5	79.99	117	167	213	316	455
	64.42	3.65	7.76	11.4	19.9	24.2	34.1	56.9	64.0	73.44	87.2	130	199	281	370
	69.63	3.01	7.31	9.46	16.8	21.1	29.3	45.2	61.1	62.38	88.6	135	172	234	331
	80.01	2.93	6.24	9.17	16.1	19.5	28.3	45.9	58.1	61.16	84.5	120	164	229	268
	91.41	2.62	5.57		12.1		17.2			41.52	74.8	92.1	159	212	239
	99.38	2.06	4.42	7.09	12.3	15.1	21.6	32.4	44.1	44.71	64.1	97.4	130	170	259
	111.5	2.11	4.48	6.58	11.5	11.8	20.3	32.9	34.8	43.85	61.1	69.6	121	147	195
	121.4														210
	138.5	1.48	3.17	5.08	8.62	10.8	15.5	24.3	31.8	33.16	46.4	69.6	92.9	123	
	159.8	1.51	3.21												
	193.1	1.06	2.28	3.17	5.23	6.34	9.51			20.60	27.3				92.3
265.4	0.55	1.09													
Quadruple	121.4	1.75	4.25	6.30	9.93	13.4	18.7	30.4	38.7	40.51	56.5	69.4	111.4	153	
	138.5			5.38	9.64	11.4									177
	159.8			4.32	7.74	9.18	15.1	24.5	31.5	32.68	45.7	64.5	89.9	124	131
	193.1						12.5	19.8	25.4	26.36	37.2	52.1	72.5	101	
	206.2	1.24	2.64	3.49	6.25	7.41	11.1	17.6	22.5	23.43	33.1	40.1	64.4	89.8	107
	238.2	1.00	2.12	3.10	5.56	6.59	10.1	16.0	20.5	21.27	30.2	42.0	58.5	81.7	107
	265.4	0.82	2.00	2.81	5.04	5.98	8.98	14.2	18.2	18.90	26.8	37.3	52.0	72.9	97.5
	295.7	0.80	1.71	2.50	4.48	5.32	7.72	12.3	15.8	16.08	22.8	33.9	45.0	61.4	87.0
	330.1	0.72	1.61	2.17	3.78	4.73	7.24	11.4	14.7	15.25	21.7	30.1	41.9	59.1	80.9
	369.8	0.64	1.45	2.02	3.62	4.29	6.44	10.2	11.9	13.55	19.4	23.2	37.3	52.7	70.8
	412.1	0.58	1.30	1.79	3.21	3.81	5.53	8.84	11.4	11.92	16.5	24.3	33.1	44.6	65.8
	459.0	0.45	1.04	1.56	2.71	3.39	5.19	8.20	10.5	10.93	15.7	21.6	30.1	42.8	58.7
	532.5	0.46	1.04	1.45	2.59	3.08	3.97	6.34	8.21	8.54	12.0	17.4	23.7	32.3	51.4
	617.9	0.41	0.93	1.12	1.95	2.48	3.72	5.88	6.51	7.84	11.4	13.1	21.5	27.9	37.2
	660.6	0.33	0.74												34.6
	741.2	0.33	0.75	1.04	1.86	1.95	2.84	4.54	5.93	6.12	8.65	12.5	17.0	23.5	
	900.3	0.23	0.53	0.80	1.40	1.78									
1057	0.24	0.54	0.57	0.94	1.19	1.70			3.68	5.18					
1255	0.17	0.38	0.50	0.83	1.05										
1785	0.10	0.17													
Quintuple	660.6						3.57	5.59	7.23	7.66	11.1	12.4	21.1	30.3	
	741.2														38.8
	900.3						2.75	3.92	5.58	5.49	8.03	11.5	15.1	21.9	31.5
	1057							3.64	4.50			9.30	13.4	19.5	26.2
	1255						1.98	2.81	4.00	3.94	5.81	7.17	10.8	15.8	22.9
1785						1.27	2.02	2.63	2.82	4.20	5.38	7.76	10.4	16.4	

Torque Ratings (lb-in) at 1430 RPM

TABLE 14

Low Speed Shaft Torque Ratings at 1450 RPM Input

Reduction	Nominal Ratio	Mercury	Mars	Venus	Atlas	Luna	Earth	Polaris	Delta	Neptune	Neptune Plus	Orion Plus	Saturn Plus	Titan Plus	Jupiter Plus
Single	3.53	4000	8000	16000			42000	54000		75000	117000	117000			
	4.39	4000	7000	16000	28000	42000	44000	52000		80000	144000	144000			
	6.12	3000	7000	17000	30000	37000	46000			85000	154000				
Double	9.30		10000		26000		50000	64000		110000					
	11.02	5000	10000	21000	36000	50000	60000	80000	133000	110000	208000	256000	250000	430000	583000
	13.85	6000	12000	22000	38000	50000	64000	85000	139000	115000	213000	265000	260000	459000	
	17.21	6000	13000	21000	38000	47000	64000	85000	139000	120000	200000	305000	320000	476000	
	20.41	6000	12000	23000	38000	41000	70000	100000	122000	130000	215000	243000	280000	507000	648000
	24.00	7000	14000	22000	38000	48000	66000	90000	140000	135000	202000	301000	350000	526000	526000
	31.63	6000	13000	19000	32000	39000	56000			120000	163000		360000	514000	
43.78	5000	10000													
Triple	31.63				38000		66000	80000		150000					
	36.56	7000	15000	23000	41000	51000	70000	110000	150000	150000	184000	274000	360000	589000	
	43.78	7000	16000	24000	41000	51000	72000	115000	151000	150000	184000	312000	380000	592000	800000
	54.45	8000	17000	24000	42000	51000	72000	120000	152000	150000	220000	314000	400000	596000	807000
	64.42	8000	17000	24000	42000	51000	72000	120000	135000	155000	184000	274000	420000	598000	813000
	69.63	7000	17000	22000	39000	49000	68000	105000	143000	145000	207000	316000	400000	548000	817000
	80.01	8000	17000	24000	42000	51000	74000	120000	153000	160000	222000	316000	430000	601000	708000
	91.41	8000	17000		38000		54000			130000	212000	261000	450000	602000	711000
	99.38	7000	15000	23000	40000	49000	70000	105000	144000	145000	209000	316000	420000	554000	825000
	111.5	8000	17000	24000	42000	43000	74000	120000	128000	160000	224000	256000	440000	540000	717000
	121.4														832000
	138.5	7000	15000	23000	39000	49000	70000	110000	145000	150000	211000	316000	420000	561000	
	159.8	8000	17000												
193.1	7000	15000	20000	33000	41000	60000			130000	173000				568000	
265.4	5000	10000													
Quadruple	121.4	7000	17000	24000	38000	51000	74000	120000	154000	160000	224000	274000	440000	608000	
	138.5			24000	43000	51000									838000
	159.8			24000	43000	51000	74000	120000	154000	160000	225000	316000	440000	611000	729000
	193.1						76000	120000	154000	160000	227000	316000	440000	615000	
	206.2	8000	17000	24000	43000	51000	76000	120000	154000	160000	227000	274000	440000	617000	735000
	238.2	8000	17000	24000	43000	51000	76000	120000	154000	160000	228000	316000	440000	618000	855000
	265.4	7000	17000	24000	43000	51000	76000	120000	154000	160000	228000	316000	440000	620000	858000
	295.7	8000	17000	24000	43000	51000	72000	115000	147000	150000	214000	316000	420000	577000	862000
	330.1	8000	18000	23000	40000	50000	76000	120000	154000	160000	230000	316000	440000	624000	865000
	369.8	8000	18000	24000	43000	51000	76000	120000	141000	160000	230000	274000	440000	626000	869000
	412.1	8000	18000	24000	43000	51000	72000	115000	148000	155000	216000	316000	430000	584000	872000
	459.0	7000	16000	23000	40000	50000	76000	120000	154000	160000	231000	316000	440000	629000	876000
	532.5	8000	18000	24000	43000	51000	72000	115000	149000	155000	218000	316000	430000	591000	881000
	617.9	8000	18000	23000	40000	51000	76000	120000	134000	160000	233000	269000	440000	574000	767000
	660.6	7000	16000												769000
	741.2	8000	18000	24000	43000	45000	72000	115000	150000	155000	220000	316000	430000	598000	
	900.3	7000	16000	23000	40000	51000									
1057	8000	18000	20000	33000	42000	60000			130000	184000					
1255	7000	16000	20000	33000	43000										
1785	6000	10000													
Quintuple	660.6						76000	120000	154000	160000	233000	274000	440000	635000	
	741.2														891000
	900.3						76000	115000	154000	160000	235000	316000	440000	641000	899000
	1057							120000	154000			316000	440000	643000	905000
	1255						76000	115000	154000	160000	237000	274000	440000	647000	905000
1785						72000	115000	149000	160000	239000	316000	440000	595000	905000	

Power Ratings (HP) at 1430 RPM

TABLE 15

Mechanical Input HP Ratings 1450 RPM Input

Reduction	Nominal Ratio	Mercury	Mars	Venus	Atlas	Luna	Earth	Polaris	Delta	Neptune	Neptune Plus	Orion Plus	Saturn Plus	Titan Plus	Jupiter Plus	
Single	3.53	24.8	53.6	121			318	408		533.05	908	908				
	4.39	19.9	37.6	98	171	239.8	269	318		459.31	901	901				
	6.12	10.7	27.0	74.4	131	150.4	201			349.43	691					
Double	9.30		26.7		69.1		133	174		281.72						
	11.02	11.7	24.5	47.8	82.0	114	140	187	311	241.58	486	598	584	1005		
	13.85	10.4	21.4	40.4	69.8	92	121	160	262	203.75	402	500	490	802	1087	
	17.21	8.39	18.7	31.1	56.4	69.7	97	129	211	171.55	304	464	487	671		
	20.41	6.74	13.8	30.3	50.1	54.0	95	135	165	165.16	291	328	378	635	811	
	24.00	7.21	14.4	23.4	40.4	51.0	72.0	98	153	138.38	220	328	382	532	509	
	31.63	4.84	10.8	15.2	24.4	29.7	43.8			88.17	127		304	402		
43.78	2.82	5.94														
Triple	31.63				29.65		54.2	65.7		118.69						
	36.56	4.58	9.8	15.8	28.1	35.0	49.3	77.5	105.6	101.81	130	193	253	394		
	43.78	3.91	8.9	13.3	22.7	28.3	40.9	65.3	85.8	82.14	105	177	216	320	461	
	54.45	3.81	8.09	10.7	18.8	22.8	33.0	55.0	69.7	66.27	101	144	183	260	375	
	64.42	3.06	6.50	9.53	16.7	20.3	29.3	48.9	55.0	60.85	74.9	112	171	232	305	
	69.63	2.52	6.12	7.93	14.1	17.7	25.1	38.8	52.9	51.68	76.5	117	148	193	272	
	80.01	2.46	5.23	7.69	13.5	16.3	24.3	39.4	50.3	50.68	72.9	104	141	188	221	
	91.41	2.20	4.67		10.2		14.5			34.40	64.6	79.5	130	174	197	
	99.38	1.73	3.71	5.94	10.3	12.7	18.6	27.8	38.2	37.05	55.4	83.8	111	140	213	
	111.5	1.77	3.75	5.51	9.65	9.88	17.4	28.3	30.2	36.33	52.8	60.3	104	121	160	
	121.4															173
	138.5	1.24	2.66	4.26	7.23	9.08	13.3	20.9	27.6	27.48	40.1	60.0	79.8	101		
	159.8	1.27	2.69													
193.1	0.89	1.91	2.66	4.38	5.45	8.17			17.08	23.6					76.0	
265.4	0.45	0.91														
Quadruple	121.4	1.43	3.47	5.15	8.11	10.9	15.7	25.5	32.7	33.56	47.5	58.1	93.4	126		
	138.5			4.39	7.87	9.34									145	
	159.8			3.53	6.33	7.50	12.7	20.5	26.4	27.07	38.5	54.1	75.3	102	108	
	193.1						10.5	16.6	21.3	21.84	31.3	43.6	60.8	82.8		
	206.2	1.02	2.16	2.85	5.10	6.05	9.33	14.7	18.9	19.41	27.9	33.6	54.0	73.8	87.8	
	238.2	0.82	1.73	2.54	4.54	5.39	8.47	13.4	17.2	17.62	25.4	35.2	49.0	67.1	88.0	
	265.4	0.67	1.63	2.30	4.12	4.88	7.52	11.9	15.2	15.66	22.6	31.3	43.6	59.8	80.2	
	295.7	0.66	1.39	2.05	3.66	4.35	6.47	10.3	13.2	13.32	19.2	28.4	37.7	50.6	71.6	
	330.1	0.59	1.32	1.78	3.09	3.86	6.07	9.58	12.3	12.63	18.4	25.2	35.1	48.6	66.6	
	369.8	0.53	1.19	1.65	2.96	3.51	5.39	8.52	10.0	11.23	16.3	19.4	31.2	43.3	58.2	
	412.1	0.47	1.06	1.47	2.63	3.12	4.64	7.41	9.54	9.88	13.9	20.4	27.7	36.7	54.2	
	459.0	0.37	0.85	1.28	2.22	2.77	4.35	6.87	8.82	9.06	13.2	18.1	25.2	35.1	48.4	
	532.5	0.38	0.85	1.18	2.12	2.51	3.33	5.31	6.88	7.08	10.1	14.6	19.9	26.6	42.3	
	617.9	0.34	0.76	0.91	1.59	2.03	3.12	4.93	5.50	6.49	9.56	11.0	18.1	23.0	30.7	
	660.6	0.27	0.61													28.5
741.2	0.27	0.61	0.85	1.52	1.59	2.38	3.81	4.97	5.07	7.28	10.5	14.2	19.3			
900.3	0.19	0.44	0.66	1.14	1.45											
1057	0.20	0.44	0.46	0.77	0.98	1.42			3.05	4.37						
1255	0.14	0.31	0.41	0.67	0.88											
1785	0.08	0.14														
Quintuple	660.6						2.91	4.57	5.91	6.35	9.12	10.1	17.2	24.8		
	741.2														31.9	
	900.3						2.25	3.20	4.56	4.55	6.59	9.42	12.3	18.0	26.0	
	1057							2.97	3.68			7.60	11.0	16.0	21.5	
	1255						1.61	2.30	3.27	3.27	4.77	5.86	8.85	13.0	18.7	
1785						1.04	1.65	2.15	2.34	3.44	4.40	6.34	8.58	13.4		

Torque Ratings (lb-in) at 1170 RPM

TABLE 16

Low Speed Shaft Torque Ratings at 1170 RPM Input

Reduction	Nominal Ratio	Mercury	Mars	Venus	Atlas	Luna	Earth	Polaris	Delta	Neptune	Neptune Plus	Orion Plus	Saturn Plus	Titan Plus	Jupiter Plus
Single	3.53	4000	8000	16000			42000	54000		75000	117000	117000			
	4.39	4000	7000	16000	28000	45000	44000	52000		80000	144000	144000			
	6.12	3000	7000	17000	30000	37000	46000			85000	155000				
Double	9.30		11000		26000		50000	64000		110000					
	11.02	5000	10000	21000	36000	50000	60000	80000	133000	110000	213000	271000	250000	457000	583000
	13.85	6000	12000	22000	38000	51000	64000	85000	148000	115000	214000	274000	260000	487000	
	17.21	6000	13000	21000	38000	48000	64000	85000	139000	120000	201000	307000	320000	506000	
	20.41	6000	12000	23000	38000	41000	70000	100000	123000	130000	216000	244000	280000	512000	676000
	24.00	7000	14000	22000	38000	48000	66000	90000	140000	135000	203000	303000	350000	530000	530000
	31.63	6000	13000	19000	32000	39000	56000			120000	164000		360000	517000	
43.78	5000	10000													
Triple	31.63				38000		66000	80000		150000					
	36.56	7000	15000	23000	41000	51000	70000	110000	151000	150000	184000	274000	360000	592000	
	43.78	7000	16000	24000	41000	51000	72000	115000	152000	150000	184000	314000	380000	595000	806000
	54.45	8000	17000	24000	42000	51000	72000	120000	152000	150000	221000	316000	400000	599000	813000
	64.42	8000	17000	24000	42000	51000	72000	120000	136000	155000	184000	274000	420000	601000	819000
	69.63	7000	17000	22000	39000	49000	68000	105000	144000	145000	208000	316000	400000	552000	823000
	80.01	8000	17000	24000	42000	51000	74000	120000	153000	160000	223000	316000	430000	604000	713000
	91.41	8000	17000		38000		54000			130000	213000	263000	450000	605000	717000
	99.38	7000	15000	23000	40000	49000	70000	105000	145000	145000	210000	316000	420000	558000	831000
	111.5	8000	17000	24000	42000	43000	74000	120000	128000	160000	225000	257000	440000	544000	723000
	121.4														838000
	138.5	7000	15000	23000	39000	49000	70000	110000	146000	150000	212000	316000	420000	565000	
	159.8	8000	17000												
193.1	7000	15000	20000	33000	41000	60000			130000	174000				573000	
265.4	5000	10000													
Quadruple	121.4	7000	17000	24000	38000	51000	74000	120000	154000	160000	225000	274000	440000	611000	
	138.5			24000	43000	51000									844000
	159.8			24000	43000	51000	74000	120000	154000	160000	227000	316000	440000	614000	735000
	193.1						76000	120000	154000	160000	228000	316000	440000	618000	
	206.2	8000	17000	24000	43000	51000	76000	120000	154000	160000	228000	274000	440000	620000	741000
	238.2	8000	17000	24000	43000	51000	76000	120000	154000	160000	229000	316000	440000	621000	862000
	265.4	7000	17000	24000	43000	51000	76000	120000	154000	160000	229000	316000	440000	623000	865000
	295.7	8000	17000	24000	43000	51000	72000	115000	148000	150000	216000	316000	420000	581000	869000
	330.1	8000	18000	23000	40000	50000	76000	120000	154000	160000	231000	316000	440000	627000	872000
	369.8	8000	18000	24000	43000	51000	76000	120000	142000	160000	231000	274000	440000	629000	876000
	412.1	8000	18000	24000	43000	51000	72000	115000	149000	155000	217000	316000	430000	588000	879000
	459.0	7000	16000	23000	40000	51000	76000	120000	154000	160000	232000	316000	440000	632000	883000
	532.5	8000	18000	24000	43000	51000	72000	115000	150000	155000	219000	316000	430000	596000	887000
	617.9	8000	18000	23000	40000	51000	76000	120000	134000	160000	234000	271000	440000	578000	773000
	660.6	7000	16000												775000
	741.2	8000	18000	24000	43000	45000	72000	115000	151000	155000	221000	316000	430000	603000	
	900.3	7000	16000	23000	40000	51000									
1057	8000	18000	20000	33000	43000	60000			130000	185000					
1255	7000	16000	20000	33000	43000										
1785	6000	10000													
Quintuple	660.6						76000	120000	154000	160000	235000	274000	440000	639000	
	741.2														898000
	900.3						76000	115000	154000	160000	236000	316000	440000	644000	905000
	1057							120000	154000			316000	440000	646000	905000
	1255						76000	115000	154000	160000	238000	274000	440000	650000	905000
1785						72000	115000	150000	160000	240000	316000	440000	599000	905000	

Power Ratings (HP) at 1170 RPM

TABLE 17

Mechanical Input HP Ratings 1170 RPM Input

Reduction	Nominal Ratio	Mercury	Mars	Venus	Atlas	Luna	Earth	Polaris	Delta	Neptune	Neptune Plus	Orion Plus	Saturn Plus	Titan Plus	Jupiter Plus	
Single	3.53	20.3	43.8	99.0			260	334		430.12	743	743				
	4.39	16.3	30.8	80.0	140	208.3	220	260		370.61	737	737				
	6.12	8.79	22.1	60.8	107	123.8	165			281.95	569					
Double	9.30		24.0		56.5		109	143		227.31						
	11.02	9.54	20.1	39.1	67.1	93.2	115	153	254	194.93	407	518	478	874		
	13.85	8.55	17.5	33.1	57.1	76.7	98.7	131	228	164.40	330	423	401	696	889	
	17.21	6.87	15.3	25.5	46.1	58.2	79.6	106	173	138.42	250	382	398	584		
	20.41	5.52	11.3	24.8	41.0	44.2	77.4	111	136	133.26	239	270	310	525	692	
	24.00	5.90	11.8	19.1	33.1	41.8	58.9	80.3	125	111.66	181	270	312	438	419	
	31.63	3.96	8.80	12.4	20.0	24.3	35.8			71.14	105		249	331		
43.78	2.31	4.86														
Triple	31.63				24.26		44.3	53.7		95.77						
	36.56	3.74	8.02	12.9	23.0	28.7	40.3	63.4	87.0	82.15	106	158	207	324		
	43.78	3.20	7.30	10.9	18.6	23.1	33.5	53.5	70.7	66.28	85.5	146	177	263	380	
	54.45	3.12	6.62	8.78	15.4	18.6	27.0	45.0	57.0	53.48	82.9	119	150	214	309	
	64.42	2.50	5.32	7.80	13.6	16.6	24.0	40.0	45.3	49.10	61.3	91.3	140	190	251	
	69.63	2.06	5.01	6.49	11.5	14.5	20.6	31.8	43.6	41.70	62.9	95.6	121	159	224	
	80.01	2.01	4.28	6.29	11.0	13.4	19.9	32.3	41.1	40.89	59.9	85.0	116	154	182	
	91.41	1.80	3.82		8.32		11.8			27.76	53.1	65.5	107	143	163	
	99.38	1.41	3.03	4.86	8.46	10.4	15.2	22.8	31.4	29.89	45.5	68.5	91.1	115	175	
	111.5	1.44	3.07	4.51	7.89	8.08	14.3	23.1	24.7	29.31	43.4	49.5	84.8	100	132	
	121.4														143	
	138.5	1.02	2.18	3.49	5.91	7.43	10.9	17.1	22.7	22.17	33.0	49.1	65.3	83.5		
	159.8	1.04	2.20													
193.1	0.73	1.56	2.17	3.59	4.46	6.69			13.77	19.4					62.7	
265.4	0.36	0.75														
Quadruple	121.4	1.17	2.84	4.21	6.64	8.95	12.8	20.8	26.7	27.08	39.1	47.6	76.4	103		
	138.5			3.60	6.44	7.64									120	
	159.8			2.89	5.18	6.14									89.1	
	193.1					10.4	16.8	21.6	21.85	31.8	44.3	61.6	83.8	88.1		
	206.2	0.83	1.77	2.33	4.18	4.95	7.63	12.0	15.5	15.66	22.9	27.5	44.2	60.7	72.4	
	238.2	0.67	1.42	2.07	3.72	4.41	6.93	10.9	14.0	14.22	20.9	28.8	40.1	55.2	72.6	
	265.4	0.55	1.34	1.88	3.37	4.00	6.16	9.72	12.5	12.64	18.5	25.6	35.6	49.2	66.1	
	295.7	0.54	1.14	1.67	3.00	3.56	5.29	8.46	10.9	10.75	15.9	23.2	30.9	41.7	59.1	
	330.1	0.48	1.08	1.45	2.53	3.16	4.97	7.84	10.1	10.19	15.1	20.6	28.8	39.9	54.9	
	369.8	0.43	0.97	1.35	2.42	2.87	4.41	6.97	8.25	9.06	13.4	15.9	25.5	35.6	48.0	
	412.1	0.39	0.87	1.20	2.15	2.55	3.80	6.06	7.85	7.97	11.4	16.7	22.7	30.2	44.7	
	459.0	0.30	0.69	1.04	1.82	2.31	3.56	5.62	7.21	7.31	10.9	14.8	20.6	28.9	39.9	
	532.5	0.31	0.70	0.97	1.73	2.06	2.72	4.35	5.67	5.71	8.28	11.9	16.2	22.0	34.9	
	617.9	0.28	0.62	0.75	1.30	1.66	2.55	4.03	4.50	5.24	7.86	9.10	14.8	18.9	25.3	
	660.6	0.22	0.50												23.5	
741.2	0.22	0.50	0.69	1.24	1.30	1.95	3.12	4.09	4.09	5.99	8.56	11.6	15.9			
900.3	0.16	0.36	0.54	0.93	1.19											
1057	0.16	0.36	0.38	0.63	0.82	1.17			2.46	3.59						
1255	0.11	0.26	0.33	0.55	0.72											
1785	0.07	0.12														
Quintuple	660.6						2.38	3.74	4.83	5.12	7.52	8.29	14.1	20.5		
	741.2														26.3	
	900.3						1.84	2.62	3.73	3.67	5.42	7.71	10.1	14.8	21.4	
	1057							2.43	3.01			6.22	8.97	13.2	17.6	
	1255						1.32	1.88	2.68	2.63	3.92	4.79	7.24	10.7	15.3	
1785						0.85	1.35	1.77	1.89	2.83	3.60	5.19	7.06	11.0		

Torque Ratings (lb-in) at 870 RPM

TABLE 18

Low Speed Shaft Torque Ratings at 870 RPM Input

Reduction	Nominal Ratio	Mercury	Mars	Venus	Atlas	Luna	Earth	Polaris	Delta	Neptune	Neptune Plus	Orion Plus	Saturn Plus	Titan Plus	Jupiter Plus
Single	3.53	4000	8000	16000			42000	54000		75000	117000	117000			
	4.39	4000	7000	16000	28000	45000	44000	52000		80000	144000	144000			
	6.12	3000	7000	17000	30000	38000	46000			85000	156000				
Double	9.30		12000		26000		50000	64000		110000					
	11.02	5000	10000	21000	36000	51000	60000	80000	133000	110000	215000	274000	250000	499000	583000
	13.85	6000	12000	22000	38000	51000	64000	85000	149000	115000	216000	274000	260000	533000	
	17.21	6000	13000	21000	38000	48000	64000	85000	140000	120000	203000	309000	320000	529000	
	20.41	6000	12000	23000	38000	42000	70000	100000	124000	130000	217000	246000	280000	517000	684000
	24.00	7000	14000	22000	38000	48000	66000	90000	141000	135000	204000	305000	350000	536000	536000
	31.63	6000	13000	19000	32000	39000	56000			120000	166000		360000	521000	
43.78	5000	10000													
Triple	31.63				38000		66000	80000		150000					
	36.56	7000	15000	23000	41000	51000	70000	110000	152000	150000	184000	274000	360000	597000	
	43.78	7000	16000	24000	41000	51000	72000	115000	152000	150000	184000	316000	380000	600000	815000
	54.45	8000	17000	24000	42000	51000	72000	120000	153000	150000	223000	316000	400000	604000	822000
	64.42	8000	17000	24000	42000	51000	72000	120000	137000	155000	184000	274000	420000	605000	829000
	69.63	7000	17000	22000	39000	49000	68000	105000	144000	145000	210000	316000	400000	558000	833000
	80.01	8000	17000	24000	42000	51000	74000	120000	154000	160000	225000	316000	430000	609000	722000
	91.41	8000	17000		38000		54000			130000	215000	265000	450000	610000	725000
	99.38	7000	15000	23000	40000	49000	70000	105000	145000	145000	211000	316000	420000	565000	841000
	111.5	8000	17000	24000	42000	43000	74000	120000	129000	160000	226000	259000	440000	549000	731000
	121.4														848000
	138.5	7000	15000	23000	39000	50000	70000	110000	147000	150000	213000	316000	420000	572000	
	159.8	8000	17000												
193.1	7000	15000	20000	33000	41000	60000			130000	176000				579000	
265.4	5000	10000													
Quadruple	121.4	7000	17000	24000	38000	51000	74000	120000	154000	160000	227000	274000	440000	616000	
	138.5			24000	43000	51000									854000
	159.8			24000	43000	51000	74000	120000	154000	160000	228000	316000	440000	619000	743000
	193.1						76000	120000	154000	160000	229000	316000	440000	623000	
	206.2	8000	17000	24000	43000	51000	76000	120000	154000	160000	230000	274000	440000	625000	749000
	238.2	8000	17000	24000	43000	51000	76000	120000	154000	160000	230000	316000	440000	626000	872000
	265.4	7000	17000	24000	43000	51000	76000	120000	154000	160000	230000	316000	440000	628000	875000
	295.7	8000	17000	24000	43000	51000	72000	115000	149000	150000	217000	316000	420000	588000	879000
	330.1	8000	18000	23000	40000	51000	76000	120000	154000	160000	232000	316000	440000	632000	881000
	369.8	8000	18000	24000	43000	51000	76000	120000	143000	160000	233000	274000	440000	634000	886000
	412.1	8000	18000	24000	43000	51000	72000	115000	150000	155000	219000	316000	430000	595000	889000
	459.0	7000	16000	23000	40000	51000	76000	120000	154000	160000	234000	316000	440000	637000	893000
	532.5	8000	18000	24000	43000	51000	72000	115000	151000	155000	221000	316000	430000	602000	898000
	617.9	8000	18000	23000	40000	51000	76000	120000	135000	160000	236000	273000	440000	584000	781000
	660.6	7000	16000												784000
	741.2	8000	18000	24000	43000	45000	72000	115000	152000	155000	223000	316000	430000	610000	
	900.3	7000	16000	23000	40000	51000									
1057	8000	18000	20000	33000	43000	60000			130000	187000					
1255	7000	16000	20000	33000	43000										
1785	6000	10000													
Quintuple	660.6						76000	120000	154000	160000	236000	274000	440000	644000	
	741.2														905000
	900.3						76000	115000	154000	160000	238000	316000	440000	649000	905000
	1057							120000	154000			316000	440000	651000	905000
	1255						76000	115000	154000	160000	240000	274000	440000	655000	905000
1785						72000	115000	151000	160000	242000	316000	440000	605000	905000	

Power Ratings (HP) at 870 RPM

TABLE 19

Mechanical Input HP Ratings 870 RPM Input

Reduction	Nominal Ratio	Mercury	Mars	Venus	Atlas	Luna	Earth	Polaris	Delta	Neptune	Neptune Plus	Orion Plus	Saturn Plus	Titan Plus	Jupiter Plus	
Single	3.53	15.1	32.6	73.6			193	248		319.83	552	552				
	4.39	12.1	22.9	59.5	104	154.9	164	193		275.58	548	548				
	6.12	6.53	16.5	45.2	79.8	92.7	122			209.66	426					
Double	9.30		19.5		42.0		80.8	106		169.03						
	11.02	7.09	14.9	29.1	49.9	70.7	85.3	114	189	144.95	306	390	355	710		
	13.85	6.36	13.0	24.6	42.5	57.0	73.4	97.5	171	122.25	248	314	298	567	661	
	17.21	5.11	11.3	18.9	34.3	43.3	59.2	78.7	130	102.93	188	286	296	454		
	20.41	4.10	8.42	18.4	30.5	33.7	57.6	82.2	102	99.09	178	202	230	394	521	
	24.00	4.39	8.77	14.2	24.6	31.1	43.8	59.7	93.6	83.03	135	202	232	330	315	
	31.63	2.95	6.55	9.25	14.8	18.1	26.6			52.90	79.0		185	248		
43.78	1.72	3.62														
Triple	31.63				18.04		33.0	40.0		71.21						
	36.56	2.78	5.97	9.61	17.1	21.3	30.0	47.1	65.1	61.09	78.8	117	154	243		
	43.78	2.38	5.43	8.09	13.8	17.2	24.9	39.7	52.5	49.28	63.6	109	131	197	286	
	54.45	2.32	4.92	6.53	11.4	13.9	20.1	33.5	42.7	39.77	62.2	88.1	112	160	232	
	64.42	1.86	3.96	5.80	10.1	12.3	17.8	29.7	33.9	36.51	45.6	67.9	104	143	189	
	69.63	1.53	3.73	4.83	8.55	10.7	15.3	23.6	32.4	31.01	47.2	71.1	90.0	119	169	
	80.01	1.50	3.18	4.68	8.19	9.94	14.8	24.0	30.8	30.41	45.0	63.2	86.0	116	137	
	91.41	1.34	2.84		6.19		8.79				20.64	39.8	49.1	79.3	107	122
	99.38	1.05	2.25	3.62	6.29	7.70	11.3	16.9	23.4	22.23	34.0	51.0	67.7	86.6	132	
	111.5	1.07	2.28	3.35	5.87	6.01	10.6	17.2	18.5	21.80	32.4	37.1	63.1	74.8	99.4	
	121.4														107	
	138.5	0.76	1.62	2.59	4.40	5.64	8.09	12.7	17.0	16.49	24.6	36.5	48.6	62.9		
	159.8	0.77	1.64													
193.1	0.54	1.16	1.62	2.67	3.31	4.97			10.24	14.6				47.1		
265.4	0.27	0.56														
Quadruple	121.4	0.87	2.11	3.13	4.93	6.66	9.55	15.5	19.9	20.14	29.3	35.4	56.8	77.5		
	138.5			2.67	4.79	5.68									90.18	
	159.8			2.15	3.85	4.57									66.9	
	193.1						7.71	12.5	16.0	16.25	23.7	32.9	45.8	62.8		
	206.2	0.62	1.31	1.73	3.11	3.68	5.67	8.96	11.5	11.65	19.2	26.5	37.0	51.0		
	238.2	0.50	1.06	1.54	2.76	3.28	5.15	8.13	10.4	10.57	15.6	21.4	29.8	41.4	54.4	
	265.4	0.41	0.99	1.40	2.51	2.97	4.58	7.23	9.27	9.40	13.9	19.0	26.5	36.9	49.8	
	295.7	0.40	0.85	1.24	2.23	2.64	3.94	6.29	8.15	8.00	11.9	17.3	23.0	31.3	44.4	
	330.1	0.36	0.80	1.08	1.88	2.40	3.69	5.83	7.48	7.58	11.3	15.4	21.4	29.9	41.3	
	369.8	0.32	0.72	1.00	1.80	2.13	3.28	5.18	6.17	6.74	10.1	11.8	19.0	26.7	36.1	
	412.1	0.29	0.64	0.89	1.60	1.90	2.82	4.51	5.88	5.92	8.58	12.4	16.9	22.7	33.6	
	459.0	0.23	0.52	0.78	1.35	1.72	2.65	4.18	5.36	5.43	8.15	11.0	15.3	21.6	30.0	
	532.5	0.23	0.52	0.72	1.29	1.53	2.02	3.23	4.24	4.25	6.21	8.88	12.1	16.5	26.2	
	617.9	0.21	0.46	0.56	0.97	1.23	1.90	3.00	3.37	3.90	5.89	6.82	11.0	14.2	19.0	
	660.6	0.16	0.37												17.7	
741.2	0.17	0.37	0.52	0.92	0.97	1.45	2.32	3.06	3.04	4.49	6.37	8.66	12.0			
900.3	0.12	0.27	0.40	0.69	0.88											
1057	0.12	0.27	0.28	0.47	0.61	0.87			1.83	2.70						
1255	0.08	0.19	0.25	0.41	0.53											
1785	0.05	0.09														
Quintuple	660.6						1.77	2.78	3.59	3.81	5.62	6.16	10.5	15.3		
	741.2														19.7	
	900.3						1.37	1.95	2.77	2.73	4.06	5.73	7.51	11.1	15.9	
	1057							1.81	2.24			4.63	6.67	9.87	13.1	
	1255						0.98	1.40	1.99	1.96	2.94	3.56	5.38	8.01	11.4	
1785						0.63	1.00	1.33	1.40	2.12	2.68	3.86	5.31	8.17		

Couplings with Straight Bore Hubs

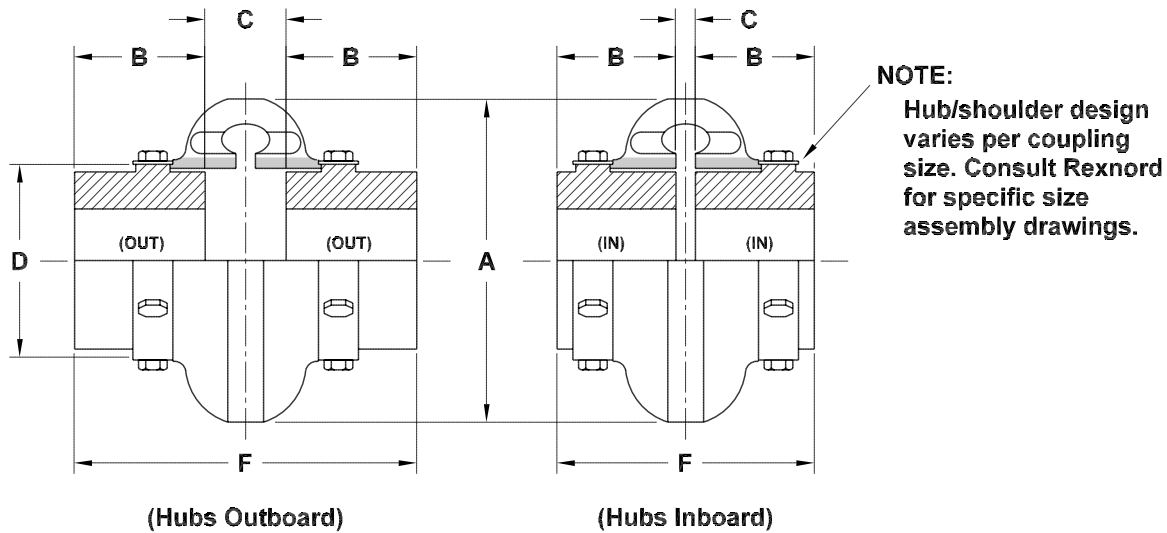

Specification Data with Straight Bore Hubs

Standard Omega No.	Recomm. Max. Bore (In.)	HP/100 RPM ①	Torque (In. Lbs.) ①	Max. RPM	Dimensions in Inches						Weight (Lbs.) ②	
					A	B	C		D	F		
							(IN)	(OUT)		(IN)		(OUT)
E4	1.63	0.88	550	7500	4.56	1.69	0.44	1.31	2.60	3.81	4.69	3.0
E5	1.88	1.48	925	7500	5.38	1.75	0.81	1.81	3.13	4.31	5.31	5.4
E10	2.13	2.30	1,450	7500	6.38	1.88	0.56	1.81	3.65	4.31	5.56	8.2
E20	2.38	3.65	2,300	6600	7.25	2.06	0.50	2.38	4.48	4.62	6.50	13.0
E30	2.88	5.79	3,650	5800	8.25	2.31	0.56	2.44	5.42	5.19	7.06	21.2
E40	3.38	8.85	5,500	5000	9.50	2.50	0.56	2.68	6.63	5.56	7.68	35
E50	3.63	12.14	7,650	4200	11.00	2.75	0.63	3.38	8.13	6.13	8.85	54
E60	4.00	19.84	12,500	3800	12.50	3.25	0.69	3.44	8.75	7.19	9.94	72
E70	4.50	35.12	22,125	3600	14.00	3.62	0.75	3.75	9.25	8.00	11.00	86
E80	6.00	62.70	39,500	2000	16.00	4.87	0.75	5.00	11.25	10.50	14.75	170
E100	6.75	135	85,050	1900	21.00	5.50	1.75	3.75	14.13	12.75	14.75	244
E120	7.50	270	170,100	1800	25.00	6.00	2.25	4.88	17.63	14.24	16.88	425
E140	9.00	540	340,200	1500	30.00	7.00	3.00	5.00	20.88	17.00	19.00	746

① Service factor = 1.0

② With max. bore standard hubs

NO OTHER COUPLING CAN OFFER ALL THESE FEATURES

- **Rapid and Easy Assembly/Disassembly** — Element consists of two halves split longitudinally. Allows for “inplace” removal/installation. No need to move connected equipment.
- **Protects Equipment** — The super flexible polyurethane element “cushions shock loads” and accommodates up to 4° angular or 3/16” parallel misalignment.
- **Reduces Vibration** — Less “wear and tear” on connected equipment. Longer system life.
- **Safe** — No metal-to-metal contact between driver and driven components. Non-sparking. Reduces the risk of fire.
- **Visual Inspection** — No need to disassemble coupling. The element can even be inspected “on-the-fly” using a strobe light.
- **Chemical Resistance** — Highly resistant to oils, corrosion and most chemicals.
- **Less Inventory** — Standard and spacer hubs are interchangeable. Adjustable spacer design meets most shaft spacing requirements without additional parts.
- **Lower Maintenance Cost** — No lubrication or service required.

Omega Coupling Selection for Scoop Mount Reducers

TABLE 20

1750 RPM Motor Speed - Class I (S.F. = 1.00)

Motor HP	Frame Size	Motor Shaft Dia. (in.)	Reducer Series and Input Shaft Diameters					
			Mercury 1-3/8"	Mars, Venus (q) & Atlas (q) 1-5/8"	Venus & Atlas (s,d,t) Earth (q) & Polaris (q) 1-7/8"	Earth & Polaris (s,d,t) Neptune Plus (q) & Orion Plus (q) 2-1/8"	Neptune, Neptune Plus & Orion Plus (s,d,t), Titan Plus (q) & Saturn Plus (q) 2-1/2"	Saturn Plus & Titan Plus (s,d,t) Jupiter Plus 3"
1	143T	7/8	E3	E4	E5			
1.5	145T	7/8	E3	E4	E5			
2	145T	7/8	E3	E4	E5	E10		
3	182T	1-1/8	E3	E4	E5	E10		
5	184T	1-1/8	E3	E4	E5	E10	E30	
7.5	213T	1-3/8	E3	E4	E5	E10	E30	
10	215T	1-3/8	E3	E4	E5	E10	E30	
15	254T	1-5/8	E3	E4	E5	E10	E30	
20	256T	1-5/8	E4	E5	E5	E10	E30	E40
25	284T	1-7/8	E5	E5	E5	E10	E30	E40
30	286T	1-7/8	E10	E10	E10	E10	E30	E40
40	324T	2-1/8		E10	E10	E10	E30	E40
50	326T	2-1/8			E20	E20	E30	E40
60	364T	2-3/8			E20	E20	E30	E40
75	365T	2-3/8			E30	E30	E30	E40
100	404T	2-7/8			E30	E30	E30	E40
125	405T	2-7/8				E40	E40	E40
150	444T	3-3/8					E40	E40
200	445T	3-3/8					E50	E50
250	447T	3-3/8					E60	E60

1750 RPM Motor Speed - Class II (S.F. = 1.40)

Motor HP	Frame Size	Motor Shaft Dia. (in.)	Reducer Series and Input Shaft Diameters					
			Mercury 1-3/8"	Mars, Venus (q) & Atlas (q) 1-5/8"	Venus & Atlas (s,d,t) Earth (q) & Polaris (q) 1-7/8"	Earth & Polaris (s,d,t) Neptune Plus (q) & Orion Plus (q) 2-1/8"	Neptune, Neptune Plus & Orion Plus (s,d,t), Titan Plus (q) & Saturn Plus (q) 2-1/2"	Saturn Plus & Titan Plus (s,d,t) Jupiter Plus 3"
1	143T	7/8	E3	E4	E5			
1.5	145T	7/8	E3	E4	E5	E10		
2	145T	7/8	E3	E4	E5	E10		
3	182T	1-1/8	E3	E4	E5	E10	E30	
5	184T	1-1/8	E3	E4	E5	E10	E30	
7.5	213T	1-3/8	E4	E4	E5	E10	E30	
10	215T	1-3/8	E4	E4	E5	E10	E30	
15	254T	1-5/8	E5	E5	E5	E10	E30	E40
20	256T	1-5/8	E10	E10	E10	E10	E30	E40
25	284T	1-7/8		E10	E10	E10	E30	E40
30	286T	1-7/8		E20	E20	E20	E30	E40
40	324T	2-1/8		E20	E20	E20	E30	E40
50	326T	2-1/8			E30	E30	E30	E40
60	364T	2-3/8			E30	E30	E30	E40
75	365T	2-3/8			E40	E40	E40	E40
100	404T	2-7/8				E40	E40	E40
125	405T	2-7/8				E50	E50	E50
150	444T	3-3/8					E50	E50
200	445T	3-3/8					E60	E60
250	447T	3-3/8						E70

1750 RPM Motor Speed - Class III (S.F. = 2.00)

Motor HP	Frame Size	Motor Shaft Dia. (in.)	Reducer Series and Input Shaft Diameters					
			Mercury 1-3/8"	Mars, Venus (q) & Atlas (q) 1 5/8"	Venus & Atlas (s,d,t) Earth (q) & Polaris (q) 1-7/8"	Earth & Polaris (s,d,t) Neptune Plus (q) & Orion Plus (q) 2-1/8"	Neptune, Neptune Plus & Orion Plus (s,d,t), Titan Plus (q) & Saturn Plus (q) 2-1/2"	Saturn Plus & Titan Plus (s,d,t) Jupiter Plus 3"
1	143T	7/8	E3	E4	E5	E10		
1.5	145T	7/8	E3	E4	E5	E10		
2	145T	7/8	E3	E4	E5	E10	E30	
3	182T	1-1/8	E3	E4	E5	E10	E30	
5	184T	1-1/8	E3	E4	E5	E10	E30	
7.5	213T	1-3/8	E4	E4	E5	E10	E30	
10	215T	1-3/8	E5	E5	E5	E10	E30	E40
15	254T	1-5/8	E10	E10	E10	E10	E30	E40
20	256T	1-5/8		E10	E10	E10	E30	E40
25	284T	1-7/8		E20	E20	E20	E30	E40
30	286T	1-7/8		E20	E20	E20	E30	E40
40	324T	2-1/8			E30	E30	E30	E40
50	326T	2-1/8			E30	E30	E30	E40
60	364T	2-3/8			E40	E40	E40	E40
75	365T	2-3/8				E40	E40	E40
100	404T	2-7/8				E50	E50	E50
125	405T	2-7/8				E60	E60	E60
150	444T	3-3/8					E60	E60
200	445T	3-3/8					E70	E70
250	447T	3-3/8						E70

NOTE: Taper-Lock® hub (reducer side only) required on Polaris (s,d,t) when a fan is used.

Load Location Factors — High Speed and Low Speed Shafts

TABLE 21
Load Location Factor (L_r) ① High Speed Shafts

Distance in Inches ②	Reducer Series					
	Mercury	Mars Venus (q) Atlas (q) Luna (q) Earth (qu) Polaris (qu) Delta (qu)	Venus Atlas Luna Earth (q) Polaris (q) Delta Neptune Neptune Plus (qu) Orion Plus (qu) Saturn Plus (qu) Titan Plus (qu)	Earth Polaris Delta Neptune Neptune Plus (q) Orion Plus (q)	Neptune Neptune Plus Orion Plus Saturn Plus (q) Titan Plus (q) Jupiter Plus (qu)	Saturn Plus Titan Plus Jupiter Plus
3/4	0.85	0.80	0.80	0.73	0.70	0.73
1	0.91	0.86	0.85	0.78	0.74	0.76
1-1/4	0.97	0.91	0.89	0.82	0.79	0.79
1-1/2	1.03	0.97	0.93	0.87	0.83	0.82
1-3/4	1.09	1.03	0.98	0.92	0.87	0.85
2	1.15	1.09	1.02	0.97	0.91	0.88
2-1/4	1.21	1.14	1.07	1.03	0.96	0.91
2-1/2	1.27	1.20	1.11	1.08	1.00	0.94
2-3/4	1.33	1.26	1.15	1.13	1.04	0.97
3	1.39	1.31	1.20	1.18	1.09	1.00
3-1/4		1.37	1.25	1.23	1.13	1.03
3-1/2		1.43	1.31	1.28	1.17	1.06
3-3/4			1.38	1.33	1.21	1.09
4			1.44	1.38	1.26	1.12
4-1/4			1.50	1.43	1.31	1.15
4-1/2				1.49	1.37	1.18
4-3/4					1.42	1.21
5					1.47	1.24
5-1/2					1.58	1.30
6						1.36
6-1/2						1.42

① Factor based on the distance from load centerline to reducer seal cage.
 ② Interpolate for intermediate values.
 q = quadruple reduction (values do not pertain to other reductions within this particular reducer series.)
 qu = quintuple reduction (values do not pertain to other reductions within this particular reducer series.)

TABLE 22
Load Location Factor (L_r) ① Low Speed Shafts

Distance in Inches ②	Reducer Series										
	Mercury	Mars	Venus	Atlas Luna	Earth	Polaris Delta	Neptune Neptune Plus	Orion Plus	Saturn Plus	Titan Plus	Jupiter Plus
1	0.84	0.77	0.71	0.72	0.67	0.70	0.72	0.72	0.69	0.63	0.61
1-1/4	0.88	0.81	0.75	0.74	0.70	0.73	0.74	0.74	0.71	0.65	0.63
1-1/2	0.92	0.85	0.80	0.78	0.72	0.75	0.76	0.75	0.72	0.67	0.65
1-3/4	0.96	0.89	0.84	0.81	0.75	0.78	0.78	0.77	0.74	0.69	0.67
2	1.00	0.92	0.88	0.84	0.78	0.80	0.80	0.79	0.76	0.70	0.69
2-1/4	1.04	0.96	0.92	0.87	0.81	0.83	0.82	0.81	0.78	0.72	0.70
2-1/2	1.08	1.00	0.96	0.90	0.83	0.85	0.84	0.82	0.79	0.73	0.72
2-3/4	1.12	1.04	1.00	0.93	0.86	0.88	0.86	0.84	0.81	0.75	0.73
3	1.16	1.08	1.04	0.97	0.90	0.90	0.88	0.86	0.83	0.77	0.75
3-1/4	1.20	1.11	1.08	1.00	0.95	0.93	0.90	0.88	0.85	0.78	0.77
3-1/2	1.25	1.15	1.12	1.03	1.00	0.95	0.92	0.89	0.86	0.80	0.78
3-3/4	1.29	1.19	1.16	1.06	1.05	0.97	0.94	0.91	0.88	0.82	0.80
4	1.33	1.23	1.10	1.09	1.10	1.00	0.96	0.93	0.90	0.83	0.82
4-1/4		1.26	1.25	1.12	1.14	1.02	0.98	0.95	0.91	0.85	0.89
4-1/2		1.30	1.29	1.16	1.19	1.05	1.00	0.96	0.93	0.87	0.85
4-3/4		1.34	1.33	1.19	1.24	1.07	1.02	0.98	0.95	0.88	0.87
5		1.38	1.37	1.22	1.29	1.10	1.06	1.00	0.97	0.90	0.88
5-1/2			1.45	1.28	1.38	1.15	1.12	1.04	1.00	0.93	0.91
6				1.35	1.48	1.20	1.19	1.07	1.03	0.97	0.95
6-1/2				1.41	1.57	1.25	1.25	1.11	1.07	1.00	0.97
7					1.67	1.30	1.32	1.14	1.10	1.03	1.00
7-1/2						1.35	1.39	1.18	1.14	1.07	1.03
8						1.40	1.45	1.21	1.17	1.10	1.07
8-1/2							1.52	1.25	1.21	1.13	1.10
9							1.58	1.28	1.24	1.17	1.13
9-1/2								1.32	1.28	1.20	1.17
10								1.35	1.31	1.23	1.20
10-1/2									1.34	1.27	1.23
11									1.38	1.30	1.27
12											1.30

① Factor based on the distance from load centerline to reducer seal cage.
 ② Interpolate for intermediate values.

Overhung Load Capacity — High Speed and Low Speed Shafts

TABLE 23

Overhung Load Capacity - Pounds ① High Speed Shafts

H.S. Shaft RPM ②	Reducer Series					
	Mercury	Mars Venus (q) Atlas (q) Luna (q) Earth (qu) Polaris (qu) Delta (qu)	Venus Atlas Luna Earth (q) Polaris (q) Delta (q) Neptune Plus (qu) Orion Plus (qu) Saturn Plus (qu) Titan Plus (qu)	Earth Polaris Delta Neptune Neptune Plus (q) Orion Plus (q)	Neptune Neptune Plus Orion Plus Saturn Plus (q) Titan Plus (q) Jupiter Plus (qu)	Saturn Plus Titan Plus Jupiter Plus
1750	720	679	941	1,500	1,900	2,500
1430	765	721	999	1,600	2,040	2,660
1170	813	766	1,060	1,700	2,160	2,830
870	888	837	1,160	1,860	2,360	3,100
720	940	886	1,230	1,960	2,500	3,270
580	1,000	946	1,310	2,100	2,670	3,490

① Capacities are for pure radial loads. If overhung and thrust loads are applied together or if radial loads exceed listed capacities, consult factory.

② If desired speed is not shown, use next higher speed.

q = quadruple reduction (values do not pertain to other reductions within this particular reducer series.)

qu = quintuple reduction (values do not pertain to other reductions within this particular reducer series.)

TABLE 24

Overhung Load Capacity - Pounds ① Low Speed Shafts

Approximate L.S. Shaft RPM ②	Reducer Series									
	Mercury	Mars	Venus	Atlas Luna	Earth	Polaris Delta	Neptune Neptune Plus	Orion Plus	Saturn Plus Titan Plus	Jupiter Plus
496	2,230	2,060	4,390	3,970	6,150	6,550	11,500	13,450	15,400	16,000
399	2,380	2,200	4,680	4,200	6,560	7,000	12,250	14,350	16,400	17,000
286	2,630	2,430	5,180	4,700	7,250	7,750	13,600	15,850	18,200	18,800
159	3,080	2,850	6,300	5,600	8,820	9,250	16,200	18,900	21,700	22,400
126	3,320	3,070	6,720	6,000	9,410	9,950	17,400	20,300	23,200	24,000
102	3,540	3,270	7,160	6,390	10,000	10,600	18,500	21,600	24,700	25,600
86	3,780	3,500	7,420	6,720	10,400	11,100	19,500	22,750	26,000	27,000
73	3,910	3,620	7,920	7,060	11,100	11,700	20,500	23,900	27,300	28,300
55	4,180	3,860	8,750	7,680	12,200	12,700	22,300	26,000	29,800	30,900
48	4,420	4,080	9,030	8,000	12,600	13,200	23,250	27,100	31,000	32,200
40	4,610	4,270	9,630	8,460	13,500	14,000	24,500	28,600	32,800	34,000
32	4,930	4,560	10,300	9,040	14,400	15,000	26,250	29,700	35,000	36,300
27	5,260	4,870	10,600	9,500	14,900	15,800	27,500	29,700	36,900	38,200
25	5,360	4,960	11,000	9,740	15,300	16,100	27,500	29,700	37,700	39,100
22	5,630	5,200	11,400	10,100	15,900	16,800	27,500	29,700	38,000	40,600
19.1	5,820	5,380	11,900	10,600	16,600	17,500	27,500	29,700	38,000	42,400
17.6	6,010	5,550	12,100	11,800	16,900	17,900	27,500	29,700	38,000	43,500
15.7	6,210	5,590	12,500	11,800	17,600	18,500	27,500	29,700	38,000	45,000
14.4	6,390	5,590	12,700	11,800	18,200	19,000	27,500	29,700	38,000	46,200
12.6	6,630	5,590	12,700	11,800	18,300	19,800	27,500	29,700	38,000	48,000
11.0	6,870	5,590	12,700	11,800	18,300	20,600	27,500	29,700	38,000	50,000
9.1	7,020	5,590	12,700	11,800	18,300	21,800	27,500	29,700	38,000	53,000
6.4 ③	7,020	5,590	12,700	11,800	18,300	23,000	27,500	29,700	38,000	58,900

① Capacities are for pure radial loads. If overhung and thrust loads are applied together or if radial loads exceed listed capacities, consult factory.

② Interpolate for intermediate values for a min. of 5,000 hr L10 life.

③ For slower speeds, use the capacity at 6.4 RPM.

Horizontal Service — Thermal HP Limits - 1750 RPM Input Speed

TABLE 25

Thermal HP Limits

Maximum motor HP (without service factor) that reducer will transmit continuously without overheating.

Based on 80°F ambient temperature. See page 10 for adjustment factors at different temperatures.

@Nominal Ratio	Reduction	Reducer Series																															
		Mercury		Mars		Venus		Atlas		Luna		Earth		Polaris		Delta		Neptune		Neptune Plus		Orion Plus		Saturn Plus		Titan Plus		Jupiter Plus					
		Without Fan	With Fan	Without Fan	With Fan	Without Fan	With Fan	Without Fan	With Fan	Without Fan	With Fan	Without Fan	With Fan	Without Fan	With Fan	Without Fan	With Fan	Without Fan	With Fan	Without Fan	With Fan	Without Fan	With Fan	Without Fan	With Fan	Without Fan	With Fan	Without Fan	With Fan	Without Fan	With Fan	Electric Fan	
3.53	Single	12		32	12	66					0	8	0	30			0	70	0	70	0	0											
4.39		13		11	40	35	89	20	74	20	74	0	52	0	130			0	189	0	189	0	88			0	157						
6.12		15		14		39	93	40	95	40	95	13	125					0	219	0	219												
9.30	Double	10	25	10	25			15	50			0	55	0	80			0	140														
11.02		10		10	25	29	74	18	63	18	63	0	64	0	93	0	93	0	169	0	169	0	208	0	135	0	135						
13.85		10		10		47	92	42	87	42	87	19	75	0	117	0	117	0	210	0	210	0	219	0	283	0	283	0	152	228			
17.21				10		52	97	46	91	46	91	24	80	0	130	0	130	0	234	0	234	0	249	0	342	0	342						
20.41				10		65	110	64	109	64	109	42	98	21	147	21	147	0	220	0	220	0	228	0	423	0	423	0	307	460			
24.00				11		68	113	66	111	66	111	45	102	30	156	30	156	26	237	26	237	26	249	134	466	134	466	0	330	494			
31.63				11		69	114	69	110	69	110	52	108					30	242	30	242			235	568	235	568						
36.56																																	
31.63		Triple						22	41			50	85	10	65			10	95					20	160								
36.56					8		26	44	24	43	24	43	54	91	14	77	14	77	16	104	16	104	32	124	36	174	36	174					
43.78				8		27	46	26	45	26	45	59	97	30	93	30	93	23	110	23	110	39	131	51	189	51	189	0	120	180			
54.45				8		29	48	29	47	29	47	61	98	33	96	33	96	27	115	27	115	40	132	66	203	66	203	0	134	202			
64.42						29	47	28	47	28	47	62	99	40	103	40	103	21	109	21	109	43	135	58	195	58	195	41	168	252			
69.63						30	48	29	48	29	48	62	99	34	98	34	98	29	117	29	117	43	135	72	209	72	209	16	142	214			
80.01						31	50	31	50	31	50	68	105	47	110	47	110	29	117	29	117	44	136	81	219	81	219	54	181	271			
91.41							31	50				68	105					30	118	30	118	45	137	83	221	83	221	73	200	300			
99.38						32	50	31	50	31	50	68	106	48	111	48	111	31	119	31	119	46	138	86	223	86	223	56	183	274			
111.5						33	51	33	51	33	51	70	108	50	113	50	113	30	118	30	118	44	137	92	229	92	229	82	209	314			
121.4							33	51	33	51				50	113	50	113	30	118	30	118	45	137	93	230	93	230	78	205	307			
138.5						33	52	33	51	33	51	71	108	50	113	50	113	31	119	31	119	46	138	95	232	95	232	84	211	316			
159.8							33	51	33	51				51	114	51	114	31	119	31	119	46	138	98	235	98	235	92	219	328			
193.1					33	52	33	52	33	52	71	109	53	116	53	116	32	119	32	119	46	138	102	239	102	239	92	219	328				

If the nominal ratio is not listed or no value is given above, your application will not be thermally limited. Refer to pages 7 and 10 for other conditions.

Horizontal Service — Thermal HP Limits - 1430 RPM Input Speed

TABLE 26

Thermal HP Limits

Maximum motor HP (without service factor) that reducer will transmit continuously without overheating.

Based on 80°F ambient temperature. See page 10 for adjustment factors at different temperatures.

@Nominal Ratio	Reduction	Reducer Series																																
		Mercury		Mars		Venus		Atlas		Luna		Earth		Polaris		Delta		Neptune		Neptune Plus		Orion Plus		Saturn Plus		Titan Plus		Jupiter Plus						
		Without Fan	With Fan	Without Fan	With Fan	Without Fan	With Fan	Without Fan	With Fan	Without Fan	With Fan	Without Fan	With Fan	Without Fan	With Fan	Without Fan	With Fan	Without Fan	With Fan	Without Fan	With Fan	Without Fan	With Fan	Without Fan	With Fan	Without Fan	With Fan	Without Fan	With Fan	Without Fan	With Fan	Electric Fan		
3.53	Single	14			42	33	92						0	90	0	140			0	149	0	149	0	62										
4.39		14		14		52	110	39	98	39	98	0	126	0	221			0	247	0	247	0	185			0	296							
6.12				16		55	114	56	115	56	115	64	186					13	271	13	271													
9.30	Double	10	25	10	25							25	60					15	70	0	114													
11.02				10		43	91	34	83	34	83	33	94	0	133	0	133	0	214	0	214	35	264	0	250	0	250							
13.85				10		58	107	54	103	54	103	42	103	20	154	20	154	34	248	34	248	44	273	32	371	32	371	0	237	356				
17.21				11		62	111	57	105	57	105	47	107	30	164	30	164	54	268	54	268	69	298	81	420	81	420							
20.41				11		72	121	71	120	71	120	61	122	45	178	45	178	42	256	42	256	51	280	147	486	147	486	62	369	553				
24.00				13		75	124	73	122	73	122	64	125	52	185	52	185	56	271	56	271	69	298	182	521	182	521	81	387	581				
31.63						76	124	76	121	76	121	69	130					60	274	60	274			265	604	265	604							
36.56																																		
31.63		Triple							26	46				58	95	15	70			22	108					35	175							
36.56					8		29	49	28	48	28	48	62	102	25	92	25	92	28	116	28	116	45	140	60	200	60	200						
43.78						30	51	30	50	30	50	66	107	38	105	38	105	33	122	33	122	51	146	72	212	72	212	0	142	213				
54.45						32	52	32	52	32	52	68	108	41	107	41	107	37	125	37	125	52	147	84	224	84	224	32	159	238				
64.42						32	52	31	51	31	51	68	109	47	113	47	113	32	121	32	121	55	150	77	217	77	217	59	186	279				
69.63						32	53	32	52	32	52	68	109	42	109	42	109	39	127	39	127	55	150	89	229	89	229	38	165	248				
80.01						34	54	33	54	33	54	73	114	52	119	52	119	39	127	39	127	55	150	97	237	97	237	70	196	295				
91.41									33	54			73	114					39	128	39	128	56	151	98	238	98	238	86	212	319			
99.38						34	54	34	54	34	54	74	114	53	120	53	120	40	129	40	129	57	152	100	240	100	240	72	198	297				
111.5						35	55	35	55	35	55	75	116	54	121	54	121	39	128	39	128	56	151	105	245	105	245	93	220	330				
121.4									35	55	35	55			54	121	54	121	39	128	39	128	56	151	106	246	106	246	90	216	325			
138.5						35	55	35	55	35	55	76	116	55	122	55	122	40	129	40	129	57	152	107	248	107	248	94	221	332				
159.8									35	55	35	55			56	123	56	123	40	129	40	129	57	152	110	251	110	251	101	228	341			
193.1					35	55	35	55	35	55	76	117	57	124	57	124	41	129	41	129	57	152	113	254	113	254	101	228	341					

If the nominal ratio is not listed or no value is given above, your application will not be thermally limited. Refer to pages 7 and 10 for other conditions.

Horizontal Service — Thermal HP Limits - 1170 RPM Input Speed

TABLE 27

Thermal HP Limits

Maximum motor HP (without service factor) that reducer will transmit continuously without overheating.

Based on 80°F ambient temperature. See page 10 for adjustment factors at different temperatures.

@Nominal Ratio	Reduction	Reducer Series																																
		Mercury		Mars		Venus		Atlas		Luna		Earth		Polaris		Delta		Neptune		Neptune Plus		Orion Plus		Saturn Plus		Titan Plus		Jupiter Plus						
		Without Fan	With Fan	Without Fan	With Fan	Without Fan	With Fan	Without Fan	With Fan	Without Fan	With Fan	Without Fan	With Fan	Without Fan	With Fan	Without Fan	With Fan	Without Fan	With Fan	Without Fan	With Fan	Without Fan	With Fan	Without Fan	With Fan	Without Fan	With Fan	Without Fan	With Fan	Without Fan	With Fan	Electric Fan		
3.53	Single	22			49	46	103						26	143	0	210			0	195	0	195	0	149										
4.39				16		60	117	51	108	51	108	53	170	16	271			31	269	31	269	0	242			0	375							
6.12				18		63	119	63	120	63	120	98	215					49	287	49	287													
9.30	Double	10	25	10	25			30	65			25	80	10	131			15	185															
11.02				11		50	97	43	91	43	91	50	109	25	153	25	153	32	231	32	231	69	284	0	315	0	315							
13.85				12		61	109	58	105	58	105	56	115	40	168	40	168	58	256	58	256	76	291	90	406	90	406	0	350	525				
17.21				13		64	111	60	108	60	108	60	118	48	175	48	175	72	271	72	271	94	309	127	442	127	442							
20.41						72	119	71	119	71	119	70	129	59	186	59	186	64	262	64	262	81	296	176	492	176	492	138	512	768				
24.00						74	121	73	120	73	120	73	132	64	192	64	192	74	273	74	273	94	310	202	518	202	518	156	531	796				
31.63						74	122	75	119	75	119	77	135					77	275	77	275			265	580	265	580							
36.56																																		
31.63		Triple					26	46			59	95	19	72					24	108					40	180								
36.56					29	49	28	48	28	48	63	102	31	95	31	95	34	116	34	116	52	141	72	203	72	203								
43.78					30	50	30	49	30	49	66	105	41	105	41	105	38	120	38	120	56	145	81	212	81	212	20	190	285					
54.45					31	51	31	51	31	51	67	106	43	107	43	107	41	123	41	123	57	146	90	221	90	221	63	218	327					
64.42					31	51	30	50	30	50	68	107	48	111	48	111	37	119	37	119	59	148	85	216	85	216	91	246	368					
69.63					32	51	31	51	31	51	68	107	44	108	44	108	42	124	42	124	59	148	94	225	94	225	70	225	337					
80.01					33	52	32	52	32	52	71	111	52	115	52	115	42	124	42	124	59	148	100	230	100	230	101	256	384					
91.41							32	52			71	111					42	124	42	124	60	149	101	231	101	231	117	272	408					
99.38					33	52	33	52	33	52	72	111	52	116	52	116	43	125	43	125	61	150	102	233	102	233	103	258	387					
111.5					33	53	33	53	33	53	73	112	53	117	53	117	43	125	43	125	60	149	106	237	106	237	124	279	419					
121.4							33	53	33	53			53	117	53	117	43	125	43	125	60	149	107	237	107	237	121	276	414					
138.5					34	53	33	53	33	53	73	113	54	117	54	117	44	126	44	126	61	150	108	238	108	238	126	281	421					
159.8							33	53	33	53			55	118	55	118	44	126	44	126	61	150	110	240	110	240	132	287	430					
193.1					34	53	34	53	34	53	74	113	56	119	56	119	44	126	44	126	61	150	112	243	112	243	132	287	430					

If the nominal ratio is not listed or no value is given above, your application will not be thermally limited. Refer to pages 7 and 10 for other conditions.

Vertical Service — Thermal HP Limits - 1750 RPM Input Speed

TABLE 29

Thermal HP Limits

Maximum motor HP (without service factor) that reducer will transmit continuously without overheating.

Based on 80°F ambient temperature. See page 10 for adjustment factors at different temperatures.

@Nominal Ratio	Reduction	Reducer Series																															
		Mercury		Mars		Venus		Atlas		Luna		Earth		Polaris		Delta		Neptune		Neptune Plus		Orion Plus		Saturn Plus		Titan Plus		Jupiter Plus					
		Without Fan	With Fan	Without Fan	With Fan	Without Fan	With Fan	Without Fan	With Fan	Without Fan	With Fan	Without Fan	With Fan	Without Fan	With Fan	Without Fan	With Fan	Without Fan	With Fan	Without Fan	With Fan	Without Fan	With Fan	Without Fan	With Fan	Without Fan	With Fan	Without Fan	With Fan	Without Fan	With Fan	Electric Fan	
3.53	Single	12		32	9	48					0	6	0	22			0	45	0	45	0	0											
4.39		13		11	40	26	65	14	54	14	54	0	38	0	95			0	123	0	123	0	57			0	102						
6.12		15		14		28	68	29	69	29	69	9	91					0	142	0	142												
9.30	Double	10	25	10	25			11	37			0	40	0	58			0	91														
11.02		10		10	25	21	54	13	46	13	46	0	47	0	68	0	68	0	110	0	110	0	135	0	88	0	88						
13.85		10		10		35	67	31	64	31	64	14	55	0	86	0	86	0	136	0	136	0	142	0	184	0	184	0	99	148			
17.21				10		38	71	33	66	33	66	18	59	0	95	0	95	0	152	0	152	0	162	0	223	0	223						
20.41				10		47	80	46	79	46	79	30	71	15	108	15	108	0	143	0	143	0	148	0	275	0	275	0	199	299			
24.00				11		50	83	48	81	48	81	33	74	22	114	22	114	17	154	17	154	17	162	87	303	87	303	0	214	321			
31.63				11		50	83	50	80	50	80	38	79					19	157	19	157			153	369	153	369						
36.56																																	
31.63		Triple						19	35			43	72					9	81					17	136								
36.56					8		22	38	21	37	21	37	46	78	12	65	12	65	13	88	13	88	27	105	31	148	31	148					
43.78				8		23	39	22	38	22	38	50	82	25	79	25	79	19	94	19	94	33	112	43	160	43	160	0	102	153			
54.45				8		25	41	24	40	24	40	52	84	28	82	28	82	23	97	23	97	34	112	56	173	56	173	0	114	171			
64.42						24	40	24	40	24	40	52	84	34	88	34	88	18	93	18	93	37	115	49	166	49	166	35	143	214			
69.63						25	41	25	41	25	41	52	84	29	83	29	83	25	99	25	99	37	115	61	178	61	178	13	121	182			
80.01						27	43	26	42	26	42	57	89	40	94	40	94	25	100	25	100	37	116	69	186	69	186	46	154	230			
91.41								26	43			58	89					26	100	26	100	38	116	71	188	71	188	62	170	255			
99.38						27	43	27	42	27	42	58	90	41	94	41	94	26	101	26	101	39	118	73	190	73	190	48	155	233			
111.5						28	44	28	44	28	44	60	92	42	96	42	96	26	100	26	100	38	116	78	195	78	195	70	178	267			
121.4								28	43	28	43			43	96	43	96	26	100	26	100	38	116	79	196	79	196	66	174	261			
138.5						28	44	28	44	28	44	60	92	43	96	43	96	27	101	27	101	39	118	80	197	80	197	71	179	269			
159.8								28	43	28	43			43	97	43	97	26	101	26	101	39	117	83	200	83	200	78	186	279			
193.1					28	44	28	44	28	44	61	93	45	99	45	99	27	101	27	101	39	117	87	203	87	203	78	186	279				

If the nominal ratio is not listed or no value is given above, your application will not be thermally limited. Refer to pages 7 and 10 for other conditions.

Vertical Service — Thermal HP Limits - 1170 RPM Input Speed

TABLE 31

Thermal HP Limits

Maximum motor HP (without service factor) that reducer will transmit continuously without overheating.

Based on 80°F ambient temperature. See page 10 for adjustment factors at different temperatures.

@Nominal Ratio	Reduction	Reducer Series																																
		Mercury		Mars		Venus		Atlas		Luna		Earth		Polaris		Delta		Neptune		Neptune Plus		Orion Plus		Saturn Plus		Titan Plus		Jupiter Plus						
		Without Fan	With Fan	Without Fan	With Fan	Without Fan	With Fan	Without Fan	With Fan	Without Fan	With Fan	Without Fan	With Fan	Without Fan	With Fan	Without Fan	With Fan	Without Fan	With Fan	Without Fan	With Fan	Without Fan	With Fan	Without Fan	With Fan	Without Fan	With Fan	Without Fan	With Fan	Without Fan	With Fan	Electric Fan		
3.53	Single	22			49	34	75							19	105	0	153			0	127	0	127	0	97									
4.39				16		44	85	37	79	37	79	39	124	12	198					20	175	20	175	0	157			0	244					
6.12				18		46	87	46	88	46	88	71	157							32	186	32	186											
9.30	Double	10	25	10	25			22	47					18	58					10	120													
11.02				11		36	71	32	66	32	66	36	79	18	111	18	111	21	150	21	150	45	185	0	205	0	205							
13.85				12		45	79	42	77	42	77	41	84	30	123	30	123	37	166	37	166	49	189	58	264	58	264	0	228	341				
17.21				13		47	81	44	79	44	79	44	86	35	128	35	128	47	176	47	176	61	201	82	287	82	287							
20.41						53	87	52	87	52	87	51	94	43	136	43	136	42	170	42	170	53	192	114	320	114	320	89	333	499				
24.00						54	89	53	88	53	88	53	96	47	140	47	140	48	177	48	177	61	201	131	337	131	337	102	345	518				
31.63						54	89	54	87	54	87	56	99					50	179	50	179			172	377	172	377							
36.56																																		
31.63		Triple							22	39			50	81					20	92					34	153								
36.56					25	41	24	41	24	41	53	87	27	81	27	81	29	99	29	99	44	120	61	172	61	172								
43.78					26	42	25	42	25	42	56	90	35	89	35	89	33	102	33	102	48	123	69	180	69	180	17	162	242					
54.45					27	43	26	43	26	43	57	90	37	91	37	91	35	104	35	104	48	124	77	188	77	188	54	185	278					
64.42					26	43	26	43	26	43	58	91	40	94	40	94	32	101	32	101	50	126	72	183	72	183	77	209	313					
69.63					27	43	27	43	27	43	58	91	37	92	37	92	36	106	36	106	50	126	80	191	80	191	59	191	286					
80.01					28	44	28	44	28	44	61	94	44	98	44	98	36	106	36	106	50	126	85	196	85	196	86	217	326					
91.41							27	44			60	94					36	105	36	105	51	127	86	196	86	196	99	231	347					
99.38					28	45	28	44	28	44	61	94	45	99	45	99	37	107	37	107	52	127	87	198	87	198	87	219	329					
111.5					28	45	28	45	28	45	62	95	45	99	45	99	36	106	36	106	51	126	90	201	90	201	106	237	356					
121.4							28	45	28	45			45	99	45	99	37	106	37	106	51	127	91	201	91	201	103	234	352					
138.5					29	45	28	45	28	45	62	96	46	100	46	100	37	107	37	107	52	127	92	203	92	203	107	238	358					
159.8							28	45	28	45			47	100	47	100	37	107	37	107	52	128	94	204	94	204	112	244	366					
193.1					29	45	29	45	29	45	63	96	47	101	47	101	37	107	37	107	52	128	95	207	95	207	112	244	366					

If the nominal ratio is not listed or no value is given above, your application will not be thermally limited. Refer to pages 7 and 10 for other conditions.

Vertical Service — Thermal HP Limits - 870 RPM Input Speed

TABLE 32

Thermal HP Limits

Maximum motor HP (without service factor) that reducer will transmit continuously without overheating.

Based on 80°F ambient temperature. See page 10 for adjustment factors at different temperatures.

@Nominal Ratio	Reduction	Reducer Series																																		
		Mercury		Mars		Venus		Atlas		Luna		Earth		Polaris		Delta		Neptune		Neptune Plus		Orion Plus		Saturn Plus		Titan Plus		Jupiter Plus								
		Without Fan	With Fan	Without Fan	With Fan	Without Fan	With Fan	Without Fan	With Fan	Without Fan	With Fan	Without Fan	With Fan	Without Fan	With Fan	Without Fan	With Fan	Without Fan	With Fan	Without Fan	With Fan	Without Fan	With Fan	Without Fan	With Fan	Without Fan	With Fan	Without Fan	With Fan	Without Fan	With Fan	Electric Fan				
3.53	Single					47	91							65	156	28	222			15	171	15	171	0	167											
4.39				20		55	99	49	94	49	94	79	171	61	255			50	207	50	207	39	211				71	322								
6.12						56	100	56	101	56	101	104	195					59	215	59	215															
9.30		10	25	10	25				29	55			33	73					23	133																
11.02	Double					45	82	42	79	42	79	52	98	40	137	40	137	45	175	45	175	73	216	60	269	60	269									
13.85						51	88	50	87	50	87	56	102	48	145	48	145	57	188	57	188	76	219	104	313	104	313	33	280	419						
17.21						53	90	51	88	51	88	58	103	52	149	52	149	65	195	65	195	85	228	122	331	122	331									
20.41						57	94	57	94	57	94	64	109	58	155	58	155	60	191	60	191	79	222	146	355	146	355	136	379	569						
24.00						58	95	58	95	58	95	65	111	61	158	61	158	66	196	66	196	85	228	158	367	158	367	145	388	582						
31.63						59	95	59	94	59	94	67	113					67	197	67	197			189	397	189	397									
36.56																																				
31.63		Triple							20	35			49	77					28	98					43	166										
36.56							23	39	23	38	23	38	51	81	30	79	30	79	38	108	38	108	54	132	78	191	78	191								
43.78							24	39	24	39	24	39	53	83	35	84	35	84	40	111	40	111	57	134	84	197	84	197	26	179	268					
54.45						25	40	24	40	24	40	53	84	36	85	36	85	42	112	42	112	57	135	90	203	90	203	77	209	313						
64.42						24	40	24	39	24	39	54	84	39	87	39	87	40	110	40	110	58	136	87	200	87	200	95	226	340						
69.63						25	40	24	40	24	40	54	84	37	86	37	86	43	113	43	113	58	136	92	205	92	205	81	213	320						
80.01						25	40	25	40	25	40	56	86	41	90	41	90	43	113	43	113	59	136	96	209	96	209	101	233	349						
91.41								25	40			55	86					43	113	43	113	59	136	97	210	97	210	111	243	365						
99.38						25	41	25	40	25	40	56	86	41	90	41	90	43	114	43	114	60	137	97	211	97	211	102	234	351						
111.5						26	41	26	41	26	41	57	87	42	91	42	91	43	113	43	113	59	137	100	213	100	213	116	248	371						
121.4								26	41	26	41				42	91	42	91	43	114	43	114	59	137	100	213	100	213	114	245	368					
138.5						26	41	26	41	26	41	57	87	42	91	42	91	44	114	44	114	60	137	101	214	101	214	117	248	373						
159.8								26	41	26	41				42	91	42	91	43	114	43	114	60	137	102	215	102	215	121	253	379					
193.1					26	41	26	41	26	41	57	87	43	92	43	92	44	114	44	114	60	137	104	217	104	217	121	253	379							

If the nominal ratio is not listed or no value is given above, your application will not be thermally limited. Refer to pages 7 and 10 for other conditions.

Tables

TABLE 33

Extended Usable Input Shaft Lengths

Reducer Series	Mercury	Mars Venus Quad Atlas Quad Luna Quad	Venus Earth Quad Polaris Quad Delta Quad	Atlas Luna Earth Quad Polaris Quad Delta Quad	Earth Polaris Neptune Quad Neptune Plus Quad Orion Plus Quad	Neptune, Neptune Plus Orion Plus Saturn Plus Quad Titan Plus Quad	Saturn Plus Titan Plus Jupiter Plus
Shaft Length	6.00	7.00	8.50	8.50	9.00	11.56	13.00

Extended Usable Output Shaft Lengths

Reducer Series	Mercury	Mars	Venus	Atlas/Luna	Earth	Polaris/Delta	Neptune Neptune Plus	Orion Plus	Saturn Plus
Shaft Length	7.15	12.44	11.00	13.00	12.00	14.00	16.00	17.00	19.00

TABLE 34

Nominal and Actual Reduction Ratios

@2Reduction	Nominal Ratio	Reducer Type												
		Mercury	Mars	Venus	Atlas Luna	Earth	Polaris	Delta	Neptune Neptune Plus	Orion Plus	Saturn Plus	Titan Plus	Jupiter Plus	
Single	3.53	3.75	3.75	3.32		3.32	3.32	3.32	3.32	3.32				
	4.39	4.67	4.67	4.11	4.11	4.11	4.11	4.11	4.11	4.11				
	6.12	6.50	6.50	5.74	5.74	5.74	5.74	5.74	5.74	5.74				
Double	9.30		9.41		9.45	9.45	9.45	9.45	9.45					
	11.02	10.24	10.24	11.02	11.02	11.02	11.02	11.02	11.02	11.02	11.02	11.02	12.80	
	13.85	14.06	14.06	13.66	13.66	13.66	13.66	13.66	13.66	13.66	13.66	13.66		
	17.21	17.50	17.50	16.93	16.93	16.93	16.93	16.93	16.93	16.93	16.93	16.93		
	20.41	21.78	21.78	19.05	19.05	19.05	19.05	19.05	19.05	19.05	19.05	19.05	19.08	
	24.00	24.38	24.38	23.61	23.61	23.61	23.61	23.61	23.61	23.61	23.61	23.61	24.69	
	31.63	30.33	30.33	32.94	32.94	32.94	32.94	32.94	32.94	32.94	30.49	30.49		
Triple	36.56	38.40	38.40	36.57	36.57	36.57	36.57	36.57	36.57	36.57	36.57	36.57	42.49	
	43.78	d42.25 45.00	d42.25 45.00	45.33	45.33	45.33	45.33	45.33	45.33	45.33	45.33	45.33		
	54.45	52.73	52.73	56.18	56.18	56.18	56.18	56.18	56.18	56.18	56.18	56.18	52.67	
	64.42	65.63	65.63	63.23	63.23	63.23	63.23	63.23	63.23	63.23	63.23	63.23	65.29	
	69.63	69.69	69.69	69.64	69.64	69.64	69.64	69.64	69.64	69.64	69.64	69.64	73.48	
	80.01	81.67	81.67	78.37	78.37	78.37	78.37	78.37	78.37	78.37	78.37	78.37	78.48	
	91.41	91.41	91.41	93.79	93.79	93.79	93.79	93.79	93.79 ①	84.54	84.54	84.54	88.32	
	99.38	101.63	101.63	97.15	97.15	97.15	97.15	97.15	97.15	97.15	97.15	97.15	94.89	
	111.5	113.75	113.75	109.32	109.32	109.32	109.32	109.32	109.32	109.32	109.32	109.32	109.48	
	121.4	q122.88	q122.88	q117.01	q117.64	q121.37	q121.37	q121.37	q121.37	q121.37	121.37	q121.37	q121.37	117.62
	138.5	141.56	141.56	135.51	135.51	135.51	135.51	135.51	135.51	135.51	135.51	135.51	q141.04	
				q137.12	q137.12									
	159.8	158.44	158.44	q170.64	q170.64	q150.44	q150.44	q150.44	q150.44	q150.44	q150.44	q150.44	q150.44	q169.53
193.1	197.17	197.17	189.03	189.03	189.03	189.03	189.03	189.03	189.03	189.03	189.03	189.03	182.96	
			q186.48	q186.48	q186.48	q186.48	q186.48	q186.48	q186.48	q186.48	q186.48	q186.48		
Quadruple	206.2	197.75	197.75	211.52	211.52	209.86	209.86	209.86	209.86	209.86	209.86	209.86	210.15	
	238.2	246.09	246.09	237.68	237.68	231.16	231.16	231.16	231.16	231.16	231.16	231.16	243.87	
	265.4	t274.63 261.33	t274.63 261.33	262.19	262.19	260.13	260.13	260.13	260.13	260.13	260.13	260.13	268.63	
	295.7	306.25	306.25	294.62	294.62	286.54	286.54	286.54	286.54	286.54	286.54	286.54	302.30	
	330.1	342.77	342.77	325.01	325.01	322.45	322.45	322.45	322.45	322.45	322.45	322.45	326.07	
	369.8	381.11	381.11	365.20	365.20	362.87	362.87	362.87	362.87	362.87	362.87	362.87	374.71	
	412.1	426.56	426.56	410.97	410.97	399.70	399.70	399.70	399.70	399.70	399.70	399.70	404.18	
	459.0	474.27	474.27	452.69	452.69	449.79	449.79	449.79	449.79	449.79	449.79	449.79	454.84	
	532.5	530.83	530.83	509.43	509.43	557.55	557.55	557.55	557.55	557.55	557.55	557.55	522.70	
	617.9	594.14	594.14	631.46	631.46	627.43	627.43	627.43	627.43	627.43	627.43	627.43	628.30	
	660.6	660.59	660.59			qu671.55	qu676.79	qu671.55	qu658.21	qu696.55	qu658.21	qu658.21	qu658.21	677.71
	741.2	739.38	739.38	710.61	710.61	777.74	777.74	777.74	777.74	777.74	777.74	777.74	777.74	qu719.30
	900.3	920.11	920.11	880.85	880.85	qu870.26	qu925.44	qu925.44	qu918.16	qu863.42	qu918.16	qu918.16	qu891.61	
	1057	1029.84	1029.84	1080.19	1080.19	1084.89	qu1039.89	qu1078.74	1084.89	qu1070.26	qu1033.24	qu1033.24	qu1082.28	
	1255	1281.58	1281.58	1228.72	1228.72	qu1212.15	qu1289.00	qu1212.15	qu1280.77	qu1204.40	qu1280.77	qu1280.77	qu1243.73	
1785	1785.06	1785.06			qu1784.15	qu1798.07	qu1784.15	qu1786.58	qu1850.58	qu1786.58	qu1786.58	qu1734.92		

d = double reduction t = triple reduction q = quadruple reduction qu = quintuple reduction
 ① Neptune Plus for 91.41 = 84.54

Moment of Inertia - Approximate WR² at Reducer High Speed Shaft

TABLE 35

Reduction	Nominal Ratio	Reducer Type													
		Mercury (lb-in ²)	Mars (lb-in ²)	Venus (lb-in ²)	Atlas (lb-in ²)	Luna (lb-in ²)	Earth (lb-in ²)	Polaris (lb-in ²)	Delta (lb-in ²)	Neptune (lb-in ²)	Neptune Plus (lb-in ²)	Orion Plus (lb-in ²)	Saturn Plus (lb-in ²)	Titan Plus (lb-in ²)	Jupiter Plus (lb-in ²)
Single	3.53	4.62	6.95	30.29			132.47	165.91	165.91	624.57	624.57		1246.99		
	4.39	3.67	5.36	21.73	27.59	27.59	89.11	113.42	113.42	413.40	413.40		884.49		
	6.12	2.87	3.97	14.59	18.07	18.07	51.72			237.13	237.13		526.26		
Double	9.30				19.81	19.81	46.14	67.77	67.77	205.27	205.27				
	11.02	5.45	6.10	16.31	18.56	18.56	40.59	50.31	50.31	201.01	201.01		764.45		
	13.85	4.25	4.77	12.69	14.33	14.33	29.07	36.08	36.08	140.79	140.79		528.88		
	17.21	3.42	3.89	12.19	13.70	13.70	26.44	32.97	32.97	128.28	128.28		503.47		
	20.41	3.37	3.82	9.51	10.55	10.55	19.22	23.31	23.31	89.45	89.45		330.11		
	24.00	2.73	3.16	9.26	10.22	10.22	17.87	21.72	21.72	83.03	83.03		317.08		
Triple	31.63	2.70	3.12	9.04	9.93	9.93	16.76			77.68	77.68		306.20		
	43.78	2.68	3.08												
	31.63				15.09	15.09	19.23	22.75	22.75	73.09	73.09				
	36.56	4.27	4.67	14.77	14.97	14.97	18.72	21.17	21.17	66.05	66.05		276.01		
	43.78	4.19	4.59	12.43	12.56	12.56	15.68	16.63	16.63	53.15	53.15		213.49		
	54.45	4.18	4.58	12.21	12.31	12.31	15.00	15.79	15.79	49.58	49.58		199.53		
	64.42	3.36	3.75	8.88	8.95	8.95	11.50	12.55	12.55	42.01	42.01		160.09		
	69.63	3.33	3.72	12.18	12.27	12.27	14.85	15.60	15.60	48.84	48.84		198.02		
	80.01	3.33	3.71	8.77	8.82	8.82	11.15	12.12	12.12	40.18	40.18		152.93		
	91.41	2.68	3.07		8.72	8.72	10.91			42.92	42.92		158.42		
	99.38	3.32	3.71	8.76	8.80	8.80	11.07	12.02	12.02	39.80	39.80		152.16		
	111.5	2.7	3.0	8.68	8.71	8.71	10.85	11.73	11.73	38.62	38.62		146.89		
138.5	2.66	3.04	8.67	8.70	8.70	10.81	11.68	11.68	38.43	38.43		146.49			
193.1	2.58	2.97	8.66	8.69	8.69	10.78			38.27	38.27		146.16			
Quad / Quint	121.4	4.27	4.65		4.69	4.69	14.84	15.06	15.06	19.10	19.10		66.62		
	138.50			4.66	4.68	4.68	12.47	12.61	12.61	15.93	15.93		53.53		
	159.8 ①	2.64	3.03	3.67	3.68	3.68	12.24	12.35	12.35	15.16	15.16		49.83		
	206.2	4.18	4.57	3.53	3.53	3.53	8.90	8.98	8.98	11.62	11.62		42.20		
	238.2	3.36	3.75	2.40	2.40	2.40	12.20	12.30	12.30	14.95	14.95		49.00		
	265.4	3.33	3.71	3.52	3.52	3.52	8.79	8.84	8.84	11.23	11.23		40.30		
	295.7	3.32	3.71	2.76	2.77	2.77	12.19	12.28	12.28	14.91	14.91		48.91		
	330.1	2.68	3.06	3.52	3.52	3.52	8.77	8.81	8.81	11.12	11.12		39.88		
	369.8	3.32	3.71	2.76	2.76	2.76	8.68	8.72	8.72	10.89	10.89		38.68		
	412.1	2.66	3.04	2.70	2.70	2.70	8.76	8.81	8.81	11.10	11.10		39.83		
	459.0	3.32	3.71	2.76	2.76	2.76	8.67	8.70	8.70	10.84	10.84		38.47		
	532.5	2.66	3.04	2.70	2.70	2.70	8.67	8.70	8.70	10.83	10.83		38.44		
	617.9	2.64	3.03	2.70	2.70	2.70	8.66	8.69	8.69	10.79	10.79		38.28		
	660.6	2.66	3.04				2.11	2.12	2.12	16.03	16.03		13.42		
	741.2	2.64	3.03	2.70	2.70	2.70	8.66	8.69	8.69	10.78	10.78		38.27		
	900.3	2.64	3.03	2.70	2.70	2.70	3.52	3.53	3.53	11.93	11.93		9.38		
	1057	2.64	3.03	2.92	2.92	2.92	8.66	1.86	1.86	10.78	10.78		38.26		
	1255	2.64	3.03	2.70	2.70	2.70	2.01	2.03	2.03	11.84	11.84		8.99		
1785	2.64	3.03				1.96	1.97	1.97	11.82	11.82		8.97			

To attain WR² at reducer low speed shaft (output), multiply WR² of reducer high speed shaft by the exact ratio squared.

① Mercury/Mars 159.8 ratio is a triple reduction.

NOTE: All values are approximate, contact factory for exact values.

Introduction

The following instructions apply to all standard horizontally mounted Planetgear speed reducers. To assure long life and performance of Planetgear speed reducers, the following practices should be followed.

NAMEPLATE



Rexnord® Planetgear™ 7000
Speed Reducers

REXNORD INDUSTRIES, LLC
WWW.REXNORD.COM



MODEL NO.

SERIAL NO.

CUST. PO.

SIZE

RPM IN

RATIO

RPM OUT

REDUCER ONLY

MAX. TORQUE OUT LB. IN.

SERVICE HP

SERVICE FACTOR

MOTORIZED REDUCER

MOTOR HP DATE

SERVICE CLASS OIL CAP. APPROX. U.S. GAL.

OUTPUT SPEED	AMBIENT TEMPERATURES			
	15F TO 60F (-10C TO 15C)		50F TO 125F (10C TO 52C)	
1500	ISO-VG	AGMA	ISO-VG	AGMA
BELOW 20	100	3	150	4
20 RPM AND ABOVE	100	3	150	4

OUTPUT SPEED	AMBIENT TEMPERATURES			
	15F TO 60F (-10C TO 15C)		50F TO 125F (10C TO 52C)	
1500	ISO-VG	AGMA	ISO-VG	AGMA
BELOW 20	150 EP	4 EP	320 EP	6 EP
20 RPM AND ABOVE	150 EP	4 EP	220 EP	5 EP

IMPORTANT: FILL TO THE LEVEL INDICATED WITH A PREMIUM QUALITY INDUSTRIAL TYPE PETROLEUM EXTREME PRESSURE LUBRICANT (SULFER-PHOSPHORUS TYPE) CONTAINING OXIDATION, RUST AND FOAM INHIBITORS. FOR DETAILED LUBRICATION INSTRUCTIONS, SEE LUBRICATION BULLETIN, UNDER NORMAL CONDITIONS, THE INITIAL LUBRICANT CHANGE SHOULD BE PERFORMED AFTER 250 HOURS. ALL CHANGES THEREAFTER SHOULD BE PERFORMED EVERY 2500 HOURS OR EVERY SIX MONTHS WHICHEVER COMES FIRST.

P/N 1886026201

Operation of the reducer shall not differ from the application data warranted on the nameplate. Any change from this data requires submittal of new application information along with all nameplate data to the factory for engineering approval. All data changes require a new nameplate be issued and installed on the reducer. Note location of serial number and model number on the nameplate. When contacting the factory or sales representative, have the serial number and model number available as these unique numbers fully describe the reducer and allow for the fastest and most accurate exchange of information.

SPARE AND REPAIR PARTS

When ordering parts, always give complete data from the nameplate on the Planetgear reducer. Model number and serial number information is necessary. Complete nameplate data will assure that you are receiving the correct parts. If a new nameplate is received with the new parts (as when a drive ratio is changed), replace the old nameplate on the drive with the new nameplate for future reference. Sun gears and carrier assemblies are stamped with a part number for easy identification.

INSTALLATION

All speed reducers should be mounted on a vibration-free, solid, level foundation. The normal method of mounting is horizontal. However, the unit may be oriented in other positions, including vertical. Relocation of the oil fill, oil drain, and oil level plugs may be necessary. Vertical mounting requires an oil reservoir kit. Please indicate mounting orientation if other than horizontal when ordering.

Foundation, Steel

When mounting the unit on structural steel, use of a rigid baseplate is strongly recommended. The baseplate should be designed to minimize bending, twisting and localized bending between stiffeners. The baseplate must be flat to prevent distortion of the reducer. The baseplate should extend the entire length of the unit. Bolt the unit securely to the structural steel support.

Foundation, Concrete

For best results, grout structural steel mounting pads into the mounting base. The reducer is then installed and shimmed off the structural pads. If shims are used to level or align the unit, they should be distributed evenly under all mounting pads to equalize the support load. Use a feeler gauge to determine thickness of required shims. All pads must be squarely supported to prevent distortion of the housing when the unit is bolted down.

ALIGNMENT

Align reducer with driven equipment by placing broad flat shims under all mounting pads of the reducer. Start at the low speed end and level across the length and width of the reducer. Check with feeler gauge to make certain that all pads are supported to prevent distortion of housing when reducer is bolted down. After reducer is aligned with driven equipment and bolted down, align prime mover to the reducer input shaft.

If reducer is received coupled to a motor, it has been aligned at the factory. However, because alignment may have been disturbed in shipment, it is best to check alignment and realign if necessary. The reliability and long life of the reducer requires careful installation of accessories and accurate alignment of the connecting shafts.

If the reducer is mounted onto a Planetgear baseplate and must be direct coupled to a drive shaft, shimming should be done underneath the baseplate. Shim under the baseplate until the baseplate is level and all feet are on the same plane.

After first week — Check alignment of the total system and realign if necessary. Also tighten all bolts and plugs as required. Remember to remove the load from the system before attempting to service the reducer. This action reduces the possibility of unexpected motion in the system. Check coupling for alignment to make sure that setting or vibration has not caused excessive misalignment.

COUPLING ALIGNMENT

Detailed instruction for installation of Rexnord Elastomer couplings is available from the factory, your Sales Engineer, or local distributor. The following are general instruction:

- Correct for angular misalignment by measuring the distance from coupling hub (on motor shaft) to coupling hub (on reducer input shaft) at four places each 90 degrees apart. Adjust or shim until the four readings are equal.
- Correct for parallel offset misalignment by placing a straight edge across the hub flange in two places 90 degrees apart. Adjust or shim until the straight edge lays flat on both ends.
- Recheck for angular misalignment, adjust if necessary and tighten down the connected equipment.
- Install Elastomer center member elements. Tighten all cap screws to the correct torque value listed in the coupling installation sheet.

FACE MOUNTED SCOOPS

The scoops have been designed to accommodate the motor weight and the starting torque based on the correct selections in this catalog and using standard 1750, 1430, 1170 and 950 AC motors. If a customer feels deflection is excessive, we suggest either placing a support under the end of the scoop, or drilling a hole in the end of the face scoop and installing a jack screw.

SPROCKET, PULLEY AND SHEAVE CONNECTIONS

Mount power takeoff as close as possible to the gear case in order to reduce the cantilever effect of overhung loads on the shaft bearings. If the power takeoff has only one hub, that hub should be on the outside with the plate closest to the seal cage of the reducer. Adjust belts or chains to manufacturer specifications to prevent overtightening.

Lubrication

LUBRICATION SYSTEMS

Standard horizontal shaft foot mounted drives are splash lubricated. The lubricant is picked up by the revolving elements and distributed to the bearings and gear meshes.

LUBRICATION RECOMMENDATIONS

Carefully follow lubrication instructions on the gear drive nameplate, warning tags and installation manuals furnished with the gear drive.

Lubricants listed in the manual are typical ONLY and should not be construed as exclusive recommendations. Industrial type petroleum based rust and oxidation inhibited (R & O) gear lubricants are the recommended lubricants for Mercury and Mars series drives at ambient temperatures of 15°F to 125°F (-9°C to +50°C). Industrial type sulfur-phosphorus extreme pressure (EP) gear lubricants are the recommended lubricants for Venus through Jupiter Plus series drives at ambient temperatures of 15°F to 125°F (-9°C to +50°C).

For drives operating outside the above temperature range, refer to “Synthetic Lubricants” paragraphs. Synthetic lubricants can also be used in normal climates.

VISCOSITY (IMPORTANT)

The proper grade for R & O and EP lubricants are found in **Table 37** & **Table 38**. For cold climate conditions refer to **Table 36** and the “Synthetic Lubricant” paragraphs.

Comparative Viscosity Classifications

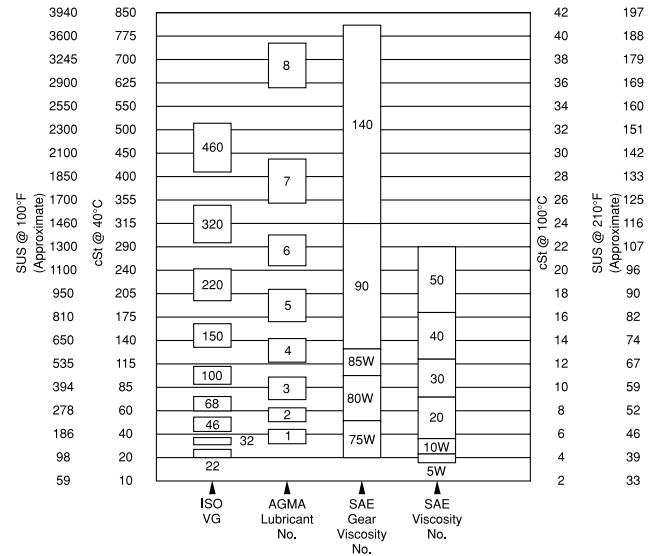

TABLE 36

Petroleum Based R & O Gear Oils ①

ISO Viscosity Grade	150	220	320	460
AGMA Viscosity Grade (Ref. Only)	4	5	6	7
Viscosity cSt @ 40°C	135-165	198-242	288-352	414-506
Viscosity SSU @ 100°F	626-765	918-1122	1335-1632	1919-2346
Manufacturer	Lubricant	Lubricant	Lubricant	Lubricant
Amoco Oil Co.	Amer. Ind. Oil 150	Amer. Ind. Oil 220	Amer. Ind. Oil 320	Amer. Ind. Oil 460
BP Oil Co.	...	Energol HLP-HD 220
Chevron U.S.A. Inc.	Machine Oil AW 150	Machine Oil AW220	Machine Oil AW 320	...
Citgo Petroleum Corp.	Citgo Pacemaker 150	Citgo Pacemaker 220	Citgo Pacemaker 320	Citgo Pacemaker 460
Conoco Inc.	Dectol R & O Oil 150	Dectol R & O Oil 220	Dectol R & O Oil 320	Dectol R & O Oil 460
Exxon Co. U.S.A.	Terresstic 150	Terresstic 220	Terresstic 320	Terresstic 460
Houghton International, Inc.	Hydro-Drive HP 750	Hydro-Drive HP 1000
Imperial Oil Ltd.	Teresso 150	Teresso 220	Teresso 320	...
Kendall Refining Co.	Four Seasons AW 150
Keystone Lubricants	KLC-40	KLC-50
Lyondell Petrochemical (ARCO)	Duro 150	Duro 220	Duro 32	...
Mobil Oil Corp.	DTE Oil Extra Heavy	DTE Oil BB	DTE Oil AA	DTE Oil HH
Pennzoil Products Company	Pennzbell AW Oil 150	Pennzbell AW Oil 220	Pennzbell AW Oil 320	Pennzbell AW Oil 460
Petro-Canada Products	Premium R & O 150	Premium R & O 220	Premium R & O 320	...
Philips 66 Co.	Magnus Oil 150	Magnus Oil 220	Magnus Oil 320	...
Shell Oil Co.	Morlina 150	Morlina 220	Morlina 320	Morlina 460
Shell Canada Limited	Tellus 150	Tellus 220	Tellus 320	...
Sun Oil Co.	Sunvis 9150	Sunvis 9220
Texaco Lubricants	Regal Oil R & O 150	Regal Oil R & O 220	Regal Oil R & O 320	Regal Oil R & O 460
Unical 76 (East)	Unax RX 150	Unax RX 220	Unax RX 320	Unax RX 460
Unical 76 (West)	Turbine Oil 150	Turbine Oil 220	Turbine Oil 320	Turbine Oil 460
Valvoline Oil Co.	Valvoline AW ISO 150	Valvoline AW ISO 220	Valvoline AW ISO 320	...

Petroleum Based Extreme Pressure Lubricants ①

ISO Viscosity Grade	150 EP	220 EP	320 EP	460 EP
AGMA Viscosity Grade (Ref. Only)	4 EP	5 EP	6 EP	7 EP
Viscosity cSt @ 40°C	135-165	198-242	288-352	414-506
Viscosity SSU @ 100°F	626-765	918-1122	1335-1632	1919-2346
Manufacturer	Lubricant	Lubricant	Lubricant	Lubricant
BP Oil Co.	Energol GR-XP 150	Energol GR-XP 220	Energol GR-XP 320	Energol GR-XP 460
Chevron U.S.A. Inc.	Gear Compounds EP 150	Gear Compounds EP 220	Gear Compounds EP 320	Gear Compounds EP 460
Citgo Petroleum Corp.	EP Compound 150	EP Compound 220	EP Compound 320	EP Compound 460
Conoco Inc.	Hydroclear EP Gear Oil 150	Hydroclear EP Gear Oil 220	Hydroclear EP Gear Oil 320	Hydroclear EP Gear Oil 460
Exxon Co. U.S.A.	Spartan EP 150	Spartan EP 220	Spartan EP 320	Spartan EP 460
Imperial Oil Ltd.	Spartan EP 150	Spartan EP 220	Spartan EP 320	Spartan EP 460
Keystone Div. Pennwalt Corp.	Carter EP Gear Oil 150	Carter EP Gear Oil 220	Carter EP Gear Oil 320	Carter EP Gear Oil 460
Mobil Oil Corp.	Mobilgear 600 XP 150	Mobilgear 600 XP 220	Mobilgear 600 XP 320	Mobilgear 600 XP 460
Petro-Canada Products	Enduratex EP 150	Enduratex EP 220	Enduratex EP 320	Enduratex EP 460
Philips 66 Co.	Philgear 150	Philgear 220	Philgear 320	Philgear 460
Shell Oil Co.	Omala Oil 150	Omala Oil 220	Omala Oil 320	Omala Oil 460
Shell Canada Limited	Omala Oil 150	Omala Oil 220	Omala Oil 320	Omala Oil 460
Sun Oil Co.	Sunep 150	Sunep 220	Sunep 320	Sunep 460
Texaco Lubricants	Meropa 150	Meropa 220	Meropa 320	Meropa 460
Valvoline Oil Co.	AGMA EP 150	AGMA EP 220	AGMA EP 320	AGMA EP 460

① Minimum viscosity index of 90. Maximum Operating Temperature 200°F (93°C).

Lubrication

TABLE 37

Viscosity Grade

Recommendations for Petroleum Based R & O Lubricants ①

Output RPM	Normal Climates			
	15° to 60°F (-9° to +16°C)		50° to 125°F (10° to +52°C)	
	ISO-VG	AGMA	ISO-VG	AGMA
Output RPM Below 20	100	3	150	4
Output RPM 20 & Above	100	3	150	4

① Recommended for Mercury and Mars series drives.

TABLE 39

Viscosity Grade Recommendations for Synthetic EP Lubricants ①

Output RPM	Cold Climates				Normal Climates			
	-30° to +10°F (-34° to -12°C)		-15° to 50°F (-26° to +10°C)		0° to 80°F (-18° to +27°C)		+10° to 125°F (-12° to +52°C)	
	ISO-VG	AGMA	ISO-VG	AGMA	ISO-VG	AGMA	ISO-VG	AGMA
Output RPM Below 20	32 EP	0 EP	68 EP	2 EP	150 EP	4 EP	320 EP	6 EP
Output RPM 20 & Above	32 EP	0 EP	68 EP	2 EP	150 EP	4 EP	220 EP	5 EP

① Refer to the Factory for viscosity recommendation when ambient temperatures are below -34°C (-30°F) or above 52°C (125°F).

TABLE 40

Synthetic Extreme Pressure Lubricants - Polyalphaolefin Type

ISO Viscosity Grade	68 EP	150 EP	220 EP	320 EP	460 EP
AGMA Viscosity Grade (Ref. Only)	2 EP	4 EP	5 EP	6 EP	7 EP
Viscosity cSt @ 40°C	61.2-74.8	135-165	198-242	288-352	414-506
Viscosity SSU @ 100°F	284-347	626-765	918-1122	1335-1632	1919-2346
Manufacturer	Lubricant	Lubricant	Lubricant	Lubricant	Lubricant
Chevron U.S.A. Inc.	...	Syn. Gear Lube Tegra 150	Syn. Gear Lube Tegra 220	Syn. Gear Lube Tegra 320	Syn. Gear Lube Tegra 460
Conoco Inc.	...	Syncon EP 150	Syncon EP 220	Syncon EP 320	Syncon EP 460
Mobil Oil Corp.	...	Mobilgear SHC 150	Mobilgear SHC 220	Mobilgear SHC 320	Mobilgear SHC 460
Mobil Oil Corp.	...	Mobilgear SHC XMP 150	Mobilgear SHC XMP 220	Mobilgear SHC XMP 320	Mobilgear SHC XMP 460
Penzoil Products Co.	Super Maxol "S" 68	Super Maxol "S" 150	Super Maxol "S" 220	Super Maxol "S" 320	Super Maxol "S" 460
Petro-Canada Products	...	Enduralex Synthetic EP 150	Enduralex Synthetic EP 220	Enduralex Synthetic EP 320	Enduralex Synthetic EP 460
Phillips 66 Company	Syndustrial EP Gear Oil 68	Syndustrial EP Gear Oil 150	Syndustrial EP Gear Oil 220	Syndustrial EP Gear Oil 320	Syndustrial EP Gear Oil 460
Shell Oil Co.	...	Omala HD 150	Omala HD 220	Omala HD 320	Omala HD 460
Sun Oil Co.	Sunoco Challenge EP 68	Sunoco Challenge EP 150	Sunoco Challenge EP 220	Sunoco Challenge EP 320	Sunoco Challenge EP 460
Texaco Lubricants Co.	...	Pinnacle EP 150	Pinnacle EP 220	Pinnacle EP 320	Pinnacle EP 460
Whitmore Mfg. Co.	...	Decathlon HD 150	Decathlon HD 220	Decathlon HD 320	Decathlon HD 460

NOTE: Minimum viscosity index of 90.

OIL LEVELS

Determine specific oil quantity needed. From the nameplate or the oil capacity chart below, determine the quantity of oil in gallons needed to operate the reducer.

Reducer Series	Reduction Type				
	Single	Double	Triple	Quadruple	Quintuple
Mercury	0.25 (0.50)	0.25 (0.50)	0.25 (0.50)	0.38 (0.61)	—
Mars	0.25 (0.50)	0.25 (0.50)	0.25 (0.50)	0.38 (0.61)	—
Venus	3.8 (5.0)	3.8 (5.0)	3.8 (5.0)	3.5 (4.5)	—
Atlas, Luna	3.8 (5.0)	3.8 (5.0)	3.8 (5.0)	3.5 (4.5)	—
Earth	5.0 (7.0)	5.0 (7.0)	5.0 (7.0)	5.0 (7.0)	5.0 (7.0)
Polaris, Delta	6.8 (8.8)	6.8 (8.8)	6.8 (8.8)	6.8 (8.8)	6.8 (8.8)
Neptune, Neptune Plus	7.8 (14.0)	7.8 (14.0)	7.8 (14.0)	8.5 (15.5)	8.3 (15.3)
Orion Plus	12.0 (19.0)	12.0 (19.0)	12.0 (19.0)	12.7 (20.0)	12.8 (21.0)
Saturn Plus	13.0 (22.5)	13.0 (22.5)	13.0 (22.5)	15.0 (25.5)	—
Titan Plus	—	15.5 (34.0)	15.5 (34.0)	17.5 (38.0)	—
Jupiter Plus	—	32.0	32.0	—	—

() - Gallon capacities for vertically orientated speed reducers

Petroleum Based R & O and Extreme Pressure (EP) Lubricants

Industrial type petroleum R & O and extreme pressure (EP) lubricants are common and readily available general purpose gear lubricants. The EP lubricants currently recommended are of the sulfur-phosphorus type.

WARNING: EP LUBRICANTS IN FOOD PROCESSING INDUSTRY - EP Lubricants may contain toxic substances and should not be used in the food processing industry without the lubricant manufacturers' approval. Lubricants which meet NSF (formerly USDA) "H1" classification are suitable for food processing applications.

Synthetic Extreme Pressure (EP) Lubricants

Synthetic Extreme Pressure (EP) lubricants of the polyalphaolefin type are recommended for all operating conditions and are particularly well suited for cold climate operations, high temperature applications, extended temperature range (all season) operations, and/or extended lubricant change intervals. The proper viscosity grade of synthetic lubricant is given in **Table 39**. Refer to **Table 40** for Synthetic lubricants.

TABLE 38

Viscosity Grade

Recommendations for Petroleum Based EP Lubricants ①

Output RPM	Normal Climates			
	15° to 60°F (-9° to +16°C)		50° to 125°F (10° to +52°C)	
	ISO-VG	AGMA	ISO-VG	AGMA
Output RPM Below 20	150 EP	4 EP	320 EP	6 EP
Output RPM 20 & Above	150 EP	4 EP	220 EP	5 EP

① Recommended for Venus through Jupiter Plus series drives.

WARNING: SYNTHETIC LUBRICANTS IN FOOD PROCESSING INDUSTRY -

Synthetic Lubricants may contain toxic substances and should not be used in the food processing industry without the lubricant manufacturers' approval. Lubricants which meet NSF (formerly USDA) "H1" classification are suitable for food processing applications.

TABLE 41

Greases for Seals 0°F to 200°F (-18° to 93°C)

Manufacturer	Lubricant
Amco Oil Co.	Amolith Grease No. 2
BP Oil Co.	Energrese LS-EP2
Chevron U.S.A. Inc.	Industrial Grease Medium
Citgo Petroleum Corp.	Premium Lithium Grease No. 2
Conoco Inc.	EP Conolith Grease No. 2
Exxon Company, U.S.A.	Unirex N2
E.F. Houghton & Co.	Cosmolube 2
Imperial Oil Ltd.	Unirex N2L
Kendall Refining Co.	Multi-Purpose Lithium Grease L421
Keystone Div. Pennwalt Corp.	Zeniplex 2
Lyondell Petrochemical (ARCO)	Litholine H Ep 2 Grease
Mobil Oil Corp.	Mobilith 22
Mobil Oil Corp.	Mobilith SHC 460 ①
Petro-Canada Limited	Multipurpose EP2
Phillips 66 Co.	Philube Blue EP
Shell Oil Co.	Alvania Grease 2
Shell Canada Limited	Alvania Grease 2
Sun Oil Co.	Ultra Prestige EP2
Texaco Lubricants	Premium RB Grease
Unocal 76 (East & West)	Unoba EP2
Valvoline Oil Co.	Multilube Lithium EP Grease

① High performance synthetic alternate.

Grease Lubricated Seals

Planetgear 7000 drives are furnished with grease purged seals which minimize the entry of contaminants into the drive. Drives are shipped with K2K #2 grease in the seal housing cavities unless otherwise specified. If grease could contaminate the product, as in the food and drug industries, it should be removed. A grease that meets NSF (formerly USDA) "H1" classification is suitable for food processing applications. Refer to **Table 41** for grease recommendations.

LUBRICANT CHANGES

Oil

For normal conditions, **change oil every six months or 2,500 hours**, whichever comes first. If operating under abnormal conditions such as high temperature, severe duty, moisture or particle contamination, oil may need to be changed more frequently. **Reference Owners' Manual** for maintenance.

NOTE: Most lubricant suppliers can test oil from the unit periodically and recommend economical oil change schedules. Oil samples should be taken from the oil level hole, not the drain hole.

Grease

All reducers are furnished with grease purgeable seals, thus minimizing entry of water or abrasive dust into the reducer. The reducers are shipped with the grease cavity filled with K2K (No. 2). For normal conditions, change grease every six months or 2,500 hours, whichever comes first. Under extreme conditions, grease may need to be changed more frequently.

STORED AND INACTIVE REDUCERS

Preparation for Storage — If a reducer is to be stored or is inactive after installation, drain oil from housing and spray all internal parts with a rust preventative oil that is soluble in a lubricating oil. Seal the reducer completely, and replace the vent plug with a solid pipe plug to keep rust inhibiting atmosphere sealed inside.

Periodically inspect stored or inactive reducers and add rust inhibitor every six months or more often if necessary. Dry indoor storage is recommended.

Rotate shafts every three months to keep the bearings from becoming lacquered.

Preparation for Start-up — Fill reducer to proper oil level, using enclosed oil capacity chart, with the recommended lubricant. Remember, reducers are supplied from the factory without oil. Rotate shafts until the bearings move freely. You are now ready to start the unit up.

Non-Horizontal Service

Planetgear speed reducers can be installed on an incline or in the vertical orientation. Contact factory or sales representative if the reducer is mounted in a rotated position with respect to the drive line.

MAXIMUM REDUCER TILT ANGLES DURING OPERATION
(STANDARD UNITS)

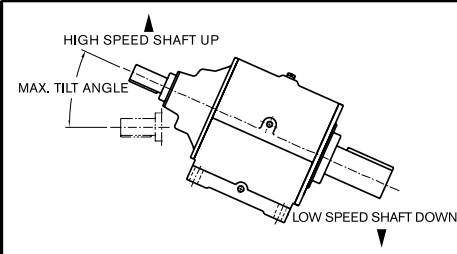
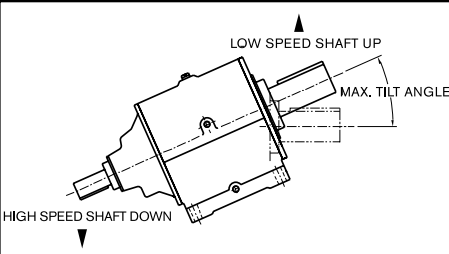
			
REDUCER SERIES	MAX. REDUCER TILT (DEGREES) HIGH SPEED SHAFT UP	REDUCER SERIES	MAX. REDUCER TILT (DEGREES) LOW SPEED SHAFT UP
MERCURY/MARS SHORT	14°	MERCURY/MARS SHORT	30°
MERCURY/MARS STANDARD	11°	MERCURY/MARS STANDARD	30°
MERCURY/MARS QUAD	8°	MERCURY/MARS QUAD	30°
VENUS (S,D,T)	10°	VENUS (S,D,T)	20°
VENUS QUAD	9°	VENUS QUAD	20°
ATLAS/LUNA (S,D,T)	10°	ATLAS/LUNA (S,D,T)	20°
ATLAS/LUNA QUAD	9°	ATLAS/LUNA QUAD	20°
EARTH (S,D,T)	9°	EARTH (S,D,T)	26°
EARTH QUAD	7°	EARTH QUAD	26°
POLARIS/DELTA (S,D,T)	7°	POLARIS/DELTA (S,D,T)	20°
POLARIS/DELTA QUAD	5°	POLARIS/DELTA QUAD	20°
NEPTUNE/NEPTUNE PLUS (S,D,T)	0°	NEPTUNE/NEPTUNE PLUS (S,D,T)	8°
NEPTUNE/NEPTUNE PLUS QUAD	0°	NEPTUNE/NEPTUNE PLUS QUAD	8°
ORION PLUS (S,D,T)	0°	ORION PLUS (S,D,T)	8°
ORION PLUS QUAD	0°	ORION PLUS QUAD	8°
SATURN PLUS (S,D,T)	0°	SATURN PLUS (S,D,T)	10°
SATURN PLUS QUAD	0°	SATURN PLUS QUAD	10°
TITAN PLUS (S,D,T)	0°	TITAN PLUS (S,D,T)	10°
TITAN PLUS QUAD	0°	TITAN PLUS QUAD	10°
JUPITER PLUS	0°	JUPITER PLUS	13°

NOTE: If any reducer application exceeds max. allowable tilt, consult factory or sales representative for possible modifications.

Vertical Service

Mercury, Mars, Venus, Atlas, Luna, Earth, Polaris and Delta speed reducers can be mounted vertically with the high speed shaft up or down. Vertical service for the Neptune, Neptune Plus and Orion Plus speed reducers is available with input shaft up only. Contact factory or sales representative for all other vertical options. Standard reducers are not designed for vertical applications. **Modifications are made at the factory to convert a standard reducer for vertical service. Contact factory or sales representative with any other applications.**

Planetgear speed reducers used in a vertical orientation or most inclined orientations require an oil reservoir lubrication system. Any mounting orientation other than horizontal must be stated during order placement so Planetgear can determine if a reservoir kit is required.

The reservoir kit works by providing an adequate head of oil to lubricate the uppermost bearing, while allowing for oil expansion. A plastic tube acts as a purge line to eliminate trapped air below the seals.

Assemble components as shown in the figure below. It is difficult to determine all potential field installation interference points. If necessary, please substitute different pipe fittings as required. In doing so, **it is important that the bottom of the reservoir is at or above the uppermost bearing.** Holes have been drilled by the factory to facilitate both right-hand or left-hand oil reservoir mounting. Apply pipe sealant to all threaded connections during assembly.

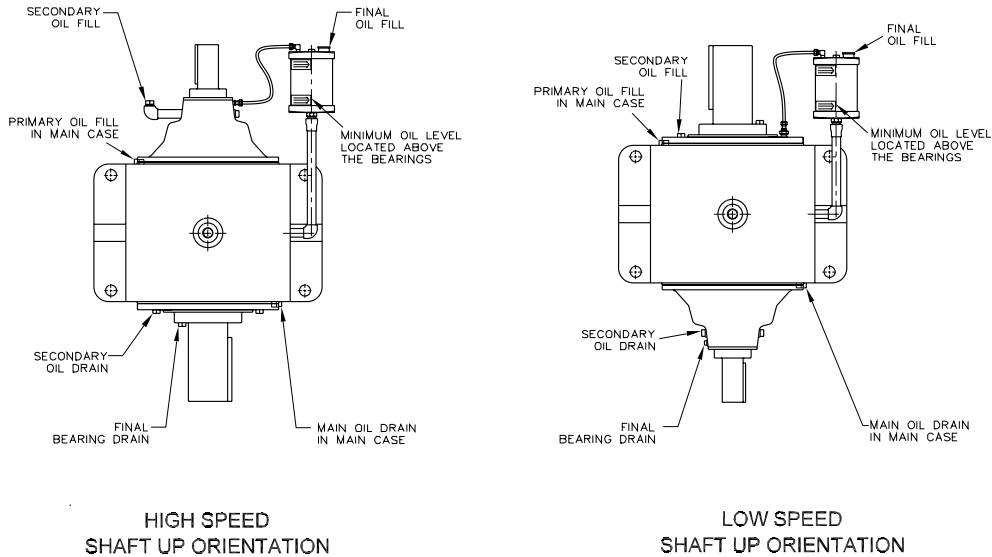
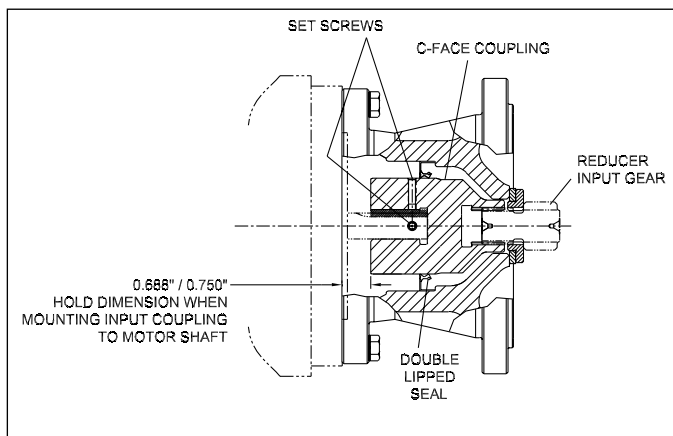
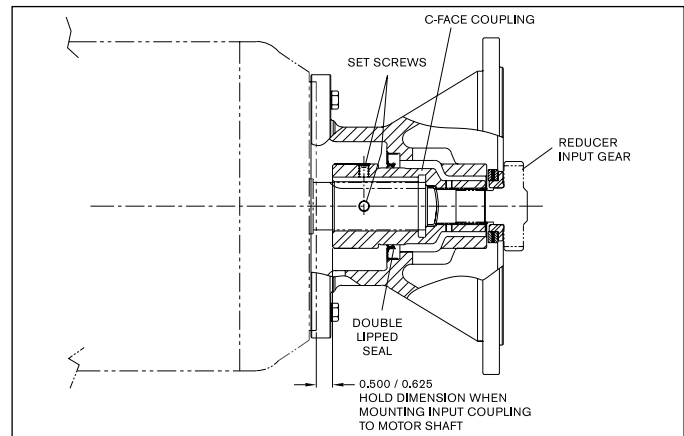

FIGURE 1
C-FACE SECTIONAL VIEWS



Mercury/Mars (single, double, triple & quadruple reductions)
Venus/Atlas/Luna (quadruple reduction)



Venus/Atlas/Luna (single, double & triple reductions)
Earth/Polaris/Delta (single, double, triple & quadruple reductions)
Neptune/Neptune Plus/Orion Plus (quadruple & quintuple reductions)

Feed Roll Drives



FEED ROLL DRIVE REPLACEMENT

- No timing of gears required
- Durable, reliable operation due to self-aligning gear train
- Drop-in replacement
- Vertical or horizontal service
- Exact ratios: (10.24, 14.06, 17.50, 18.29, 21.78, 24.38, 26.67 or 30.33)

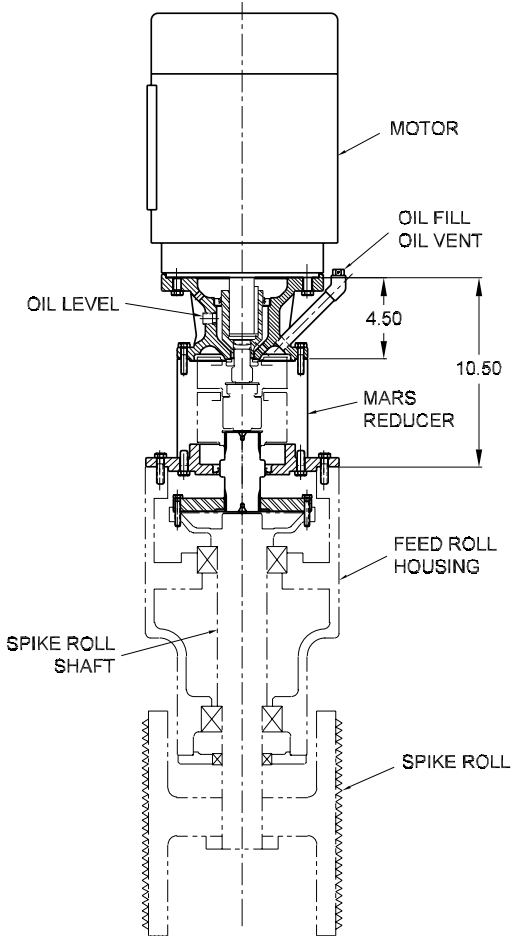

Inching Drives

PURPOSE

Primarily used for inspection of equipment to eliminate shock to the system caused by jogging the main motor.

- Available in all sizes and ratios
- Supplied with or without motors
- Consult Factory for detailed information

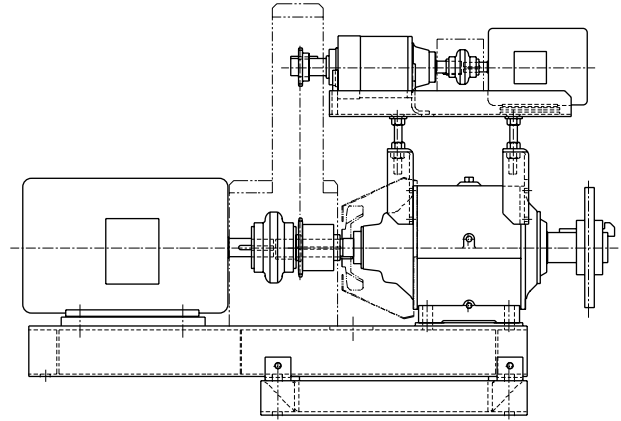

Secondary reducer/motor package offers an additional 10:1 reduction in inching mode.

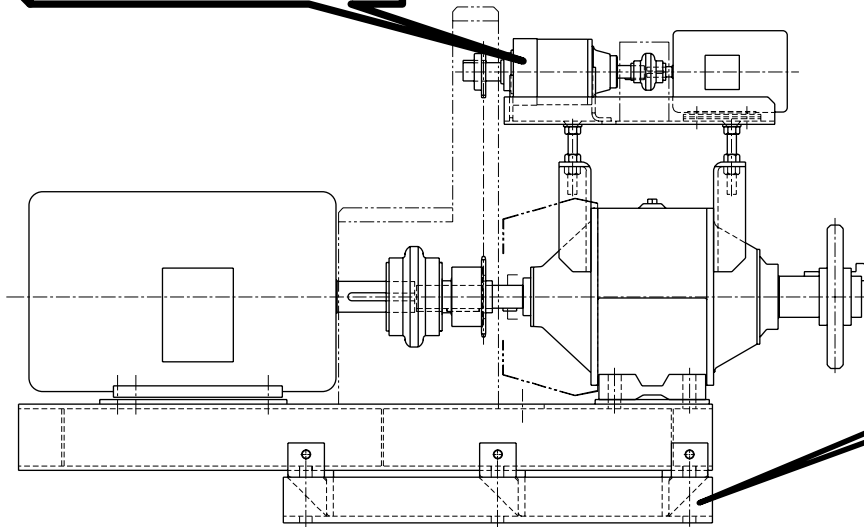

If drive shaft is chain driven, our Slidebase facilitates tensioning of the chain.

Overriding clutch disengages inching feature when not in use.

Structurally reinforced fabricated Baseplates provide for excellent foundation to mount equipment.

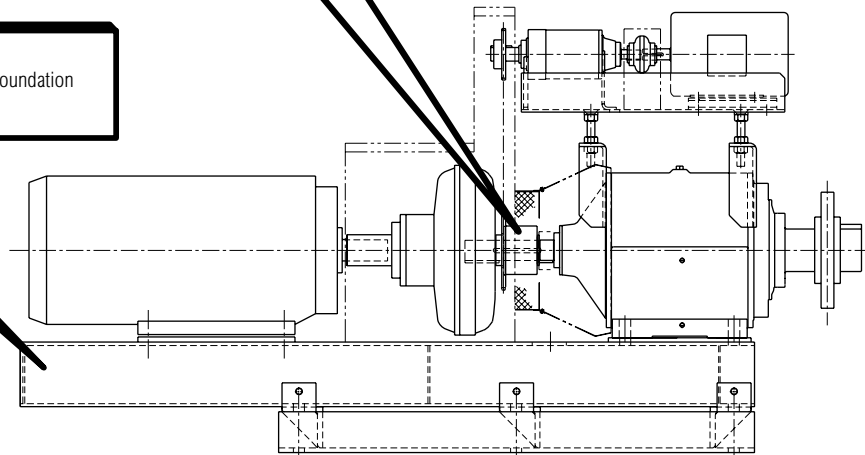

Custom Designed Adapters

Planetgear 7000 can offer special and standard input, output and reducer mounting adapters to meet most customer needs. Contact Factory with requirements.

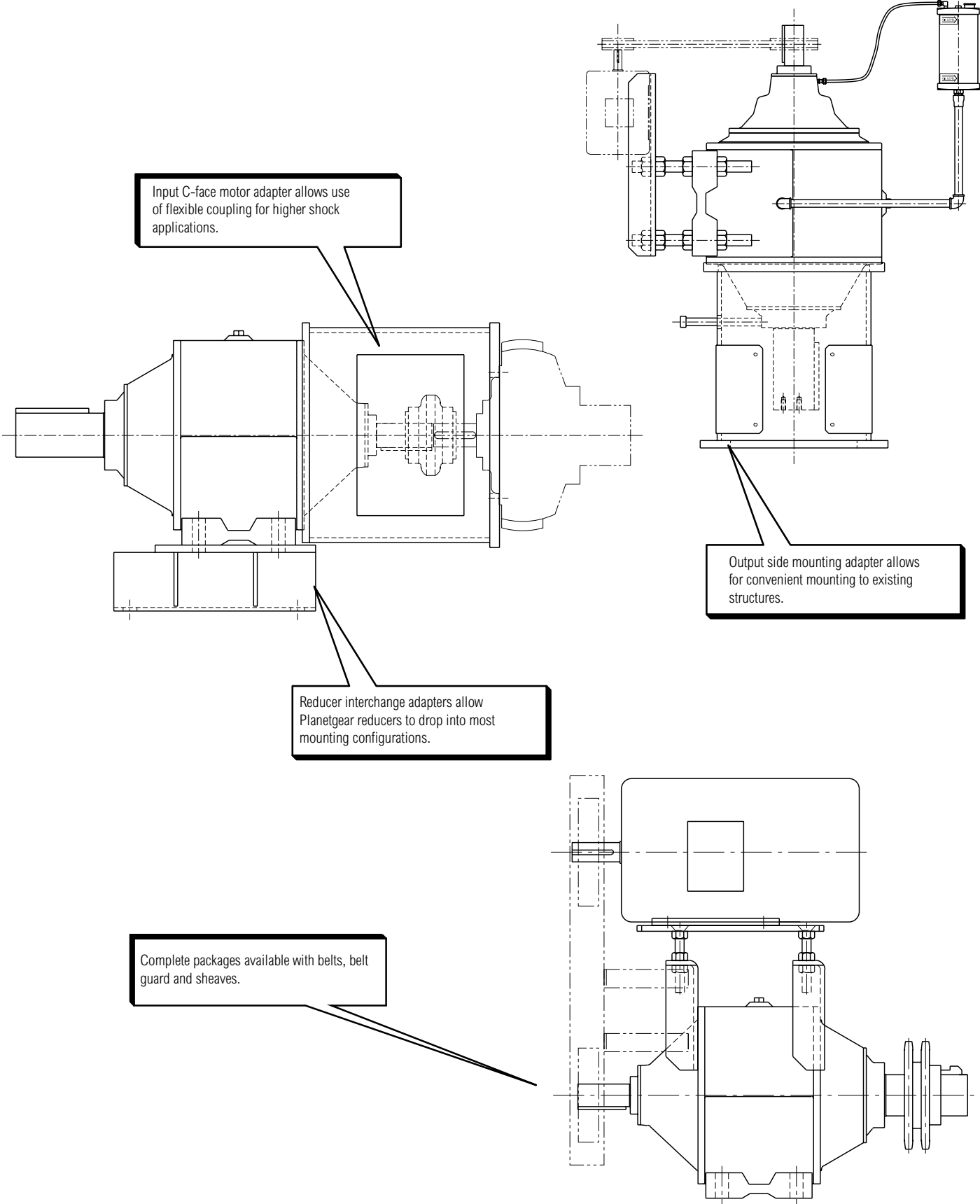

Hollow Shaft and Certified Drawings

SPECIALLY DESIGNED REDUCERS

- Hollow shaft output available with top motor mounting option
- Torque arm
- Orion, Titan and Jupiter sizes available

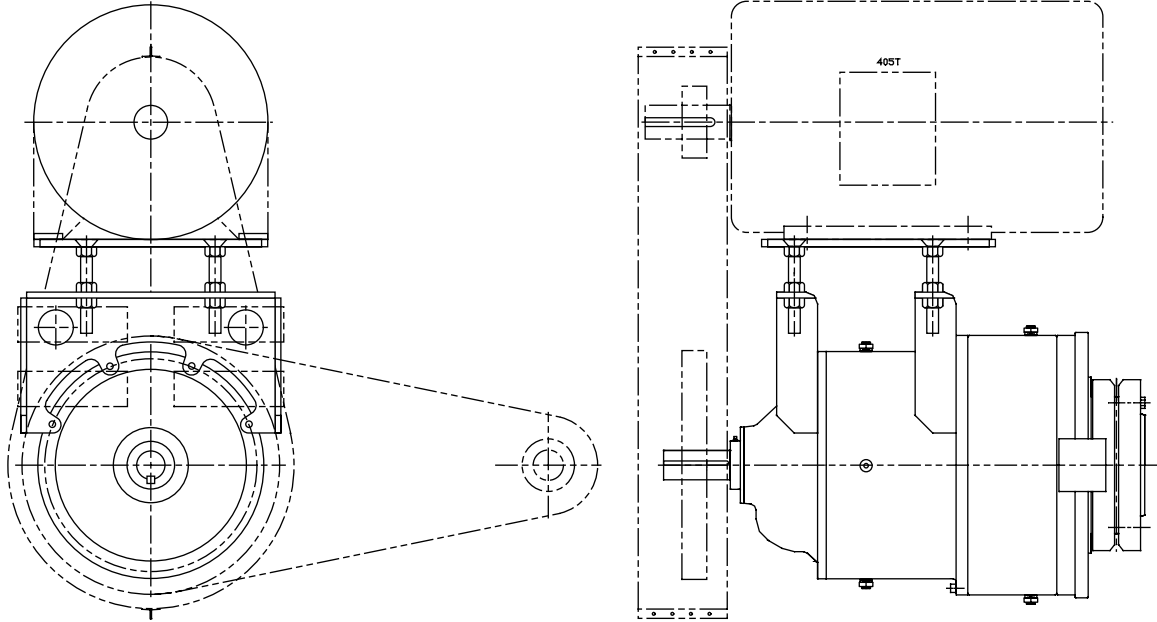



CERTIFIED REDUCER DRAWINGS

- Available upon request

<p>Customer _____ Reducer Serial No. _____ Customer PO _____ Model No. YKKG0075-_____ Installation _____ Reducer Series MARS _____ Quantity Required 24</p>	<p style="font-size: small;">CONFIDENTIAL - ALL RIGHTS RESERVED - PROPERTY OF Rexnord Corp. PLANETGEAR OPERATIONS MILWAUKEE, WISCONSIN 53201-2022 (414) 643-2584</p> <table border="1" style="width: 100%; border-collapse: collapse;"> <tr> <td style="width: 20%;">Drawing No.</td> <td style="width: 20%;">Certified By</td> <td style="width: 20%;">Date</td> <td style="width: 20%;">REV.</td> <td style="width: 20%;">DATE</td> <td style="width: 20%;">BY</td> <td style="width: 20%;">CHK.</td> </tr> <tr> <td> </td> <td> </td> <td> </td> <td> </td> <td> </td> <td> </td> <td> </td> </tr> </table>	Drawing No.	Certified By	Date	REV.	DATE	BY	CHK.							
Drawing No.	Certified By	Date	REV.	DATE	BY	CHK.									
<p>REDUCER: Max. Torque 11,000 Service Hp 2.5 Svc Factor/Class 2.1 Nominal Ratio 30.33 RPM in 872 RPM out 28.8</p>	<p>MOTOR: Frame Size CDL186ATD Hp 2.5 RPM 872 Enclosure _____ Furnished By OTHERS Mounted By OTHERS</p>	<p>ACCESSORIES: Fan & Shroud: NONE CPLG. SLEEVE 1882001101 INTG. CPLG. ASSY. MR2100202A INTG. SUB-ASSY. MR2100606A D FLNG. ADAP. INTG. 1884001601 OP ADAPTER M/M 1884001701 OP SUB-ASSY. MR2500114A</p>													
<p>Special Instructions: OP SHAFT TO BE MODIFIED PER DETAIL SHOWN.</p>															

General Power Transmission Formulas

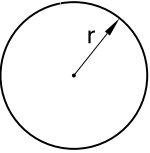
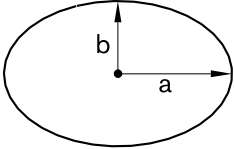
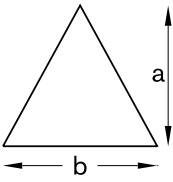
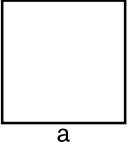
The following information helps to solve technical problems frequently encountered in the selection of power transmission components.

AREAS OF PLANE FIGURES	
FIGURE	AREA
Circle 	πr^2 circumference = $2\pi r$
Ellipse 	πab
Triangle 	$\frac{1}{2}ab$
Square 	a^2
Rectangle 	lw

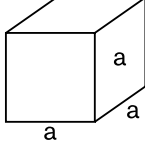
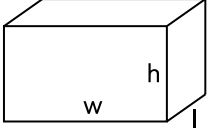
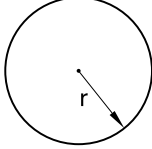
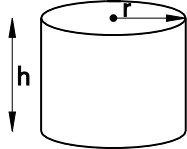
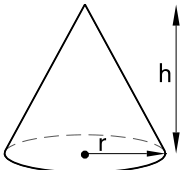
VOLUMES AND SURFACE AREAS OF SOLIDS		
SOLID	SURFACE AREA	VOLUME
Cube 	$6a^2$	a^3
Rectangular Prism 	$2hw + 2hl + 2lw$	$l \times w \times h$
Sphere 	$4\pi r^2$	$\frac{4\pi r^3}{3}$
Cylinder 	$2\pi rh + 2\pi r^2$	$\pi r^2 h$
Cone 	$\pi r \sqrt{r^2 + h^2}$ (+ πr^2 if you add the base)	$\frac{\pi r^2 h}{3}$

General Power Transmission Formulas

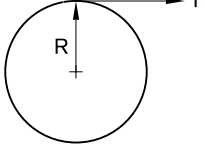
WEIGHT	
FORMULA	VARIABLES
WEIGHT (W) = V x ρ (lbs)	V = Volume (cubic inches) ρ = Material density (lbs per cubic inches)
TORQUE	
TORQUE (T) = F x R (lb-in)	F = Force (lbs) R = Perpendicular distance from the center of rotation to the force (in)
	
HORSEPOWER (HP)	
<ul style="list-style-type: none"> Rotating Objects $HP = \frac{T \times RPM}{63,025}$	T = Torque in inch-pounds (lb-in) RPM = Shaft speed revolutions per minute (rpm)
<ul style="list-style-type: none"> Objects in Linear Motion $HP = \frac{F \times V}{33,000}$	F = Force in pounds (lbs) V = Velocity in feet per minute (fpm)
<ul style="list-style-type: none"> Hydraulic $HP = \frac{GPM \times PSI}{1,714}$	GPM = Flow rate in gallons per minute (gal/min) PSI = Pressure in pounds per square inch (lb/in ²)

LINEAR TO ROTARY MOTION	
FORMULA	VARIABLES
$N = \frac{V}{0.262D}$	N = Speed of shaft rotation (rpm) V = Velocity of material (fpm) D = Diameter of pulley or sprocket (in)
ACCELERATION / DECELERATION OF TORQUE AND FORCE	
<ul style="list-style-type: none"> Rotating Objects $T = \frac{(WK^2)\Delta N}{308t}$	T = Torque required (lb-ft) WK ² = Total inertia of load to be accelerated (lb-ft ²) ΔN = Change in speed (rpm) t = Time to accelerate load
<ul style="list-style-type: none"> Objects in Linear Motion $F = \frac{W\Delta V}{1,933t}$	F = Force required (lbs) W = Weight (lbs) ΔV = Change in velocity (fpm) t = Time to accelerate load

TEMPERATURE		
TO CONVERT FROM	TO	USE FORMULA
temperature Celsius, t _C	temperature Kelvin, t _K	t _K = t _C + 273.15
temperature Fahrenheit, t _F	temperature Kelvin, t _K	t _K = (t _F + 459.67) / 1.8
temperature Celsius, t _C	temperature Fahrenheit, t _F	t _F = 1.8 t _C + 32
temperature Fahrenheit, t _F	temperature Celsius, t _C	t _C = (t _F - 32) / 1.8
temperature Kelvin, t _K	temperature Celsius, t _C	t _C = t _K - 273.15
temperature Kelvin, t _K	temperature Fahrenheit, t _F	t _F = 1.8 t _K - 459.67
temperature Kelvin, t _K	temperature Rankine, t _R	t _R = 9/5 t _K
temperature Rankine, t _R	temperature Kelvin, t _K	t _K = 5/9 t _R

Metric Conversion Factors

LENGTH		
MULTIPLY:	BY	TO OBTAIN:
centimeters	0.0328084	feet
centimeters	0.3937008	inches
feet	0.3048 ①	meters
feet	30.48 ①	centimeters
feet	304.8 ①	millimeters
inches	0.0254 ①	meters
inches	2.54 ①	centimeters
inches	25.4 ①	millimeters
kilometers	0.6213712	miles (U.S.)
meters	39.37008	inches
meters	3.280840	feet
meters	1.093613	yards
meters	0.00062137	miles (U.S.)
miles (U.S.)	1609.344 ①	meters
miles (U.S.)	1.609344 ①	kilometers
millimeters	0.003280840	feet
millimeters	0.03937008	inches
yards	0.9144 ①	meters

AREA		
MULTIPLY:	BY	TO OBTAIN:
square centimeters	0.1550003	square inches
square centimeters	0.001076391	square feet
square feet	0.09290304 ①	square meters
square feet	929.0304	square centimeters
square feet	92,903.04 ①	square millimeters
square inches	645.16 ①	square millimeters
square inches	6.4516 ①	square centimeters
square inches	0.00064516 ①	square meters
square meters	1550.003	square inches
square meters	10.763910	square feet
square meters	1.195990	square yards
square millimeters	0.00001076391	square feet
square millimeters	0.001550003	square inches

VOLUME		
MULTIPLY:	BY	TO OBTAIN:
cubic centimeters	0.06102376	cubic inches
cubic feet	0.02831685	cubic meters
cubic feet	28.31685	liters
gallons (U.K.)	0.004546092	cubic meters
gallons (U.K.)	4.546092	liters
gallons (U.S.)	0.003785412	cubic meters
gallons (U.S.)	3.785412	liters
cubic inches	16,387.06	cubic millimeters
cubic inches	16.38706	cubic centimeters
cubic inches	0.000016387	cubic meters
liters	0.001 ①	cubic meters
liters	0.2199692	gallons (U.K.)
liters	0.2641720	gallons (U.S.)
liters	0.03531466	cubic feet
cubic meters	219.9692	gallons (U.K.)
cubic meters	264.172	gallons (U.S.)
cubic meters	35.31466	cubic feet
cubic meters	1000. ①	liters
cubic meters	61,023.76	cubic inches
cubic millimeters	0.00006102	cubic inches

VELOCITY, ACCELERATION, AND FLOW		
MULTIPLY:	BY	TO OBTAIN:
centimeters/second	1.968504	feet/minute
centimeters/second	0.03280840	feet/second
centimeters/minute	0.3937008	inches/minute
feet/hour	0.00008467	meters/second
feet/hour	0.00508 ①	meters/minute
feet/hour	0.3048	meters/hour
feet/minute	0.508 ①	centimeters/second
feet/minute	18.288 ①	meters/hour
feet/minute	0.3048 ①	meters/minute
feet/minute	0.00508 ①	meters/second
feet/second	30.48 ①	centimeters/second
feet/second	18.288 ①	meters/minute
feet/second	0.3048 ①	meters/second
feet/second squared	0.3048 ①	meters/second squared
cubic feet/minute	28.31685	cubic liters/minute
cubic feet/minute	0.000471947	cubic meters/second
gallons (U.S.)/min.	0.003785412	cubic meters/minute
gallons (U.S.)/min.	0.00006309000	cubic meters/second
gallons (U.S.)/min.	0.06309020	liters/second
gallons (U.S.)/min.	3.785412	liters/minute
gallons (U.K.)/min.	0.004546092	cubic meters/minute
gallons (U.K.)/min.	0.000075768	cubic meters/second
inches/minute	25.4 ①	millimeters/minute
inches/minute	2.54 ①	centimeters/ minute
inches/minute	0.0254 ①	meters/minute
inches/second squared	0.0254 ①	meters/second squared
kilometer/hour	0.6213712	miles/hour (U.S.)
liters/minute	0.03531466	cubic feet/minute
liters/minute	0.2641720	gallons (U.S.)/minute
liters/second	15.85032	gallons (U.S.)/minute
miles/hour	1.609344 ①	kilometers/hour
millimeters/minute	0.03937008	inches/minute
meters/second	11,811.02	feet/hour
meters/second	196.8504	feet/minute
meters/second	3.28084	feet/second
meters/second squared	3.280840	feet/second squared
meters/second squared	39.37008	inches/second squared
meters/minute	3.280840	feet/minute
meters/minute	0.05468067	feet/second
meters/minute	39.37008	inches/minute
meters/hour	3.280840	feet/hour
meters/hour	0.5468067	feet/minute
cubic meters/second	2118.880	cubic feet/minute
cubic meters/second	13,198.15	gallons (U.K.)/minute
cubic meters/second	15,850.32	gallons (U.S.)/minute
cubic meters/minute	219.9692	gallons (U.K.)/minute
cubic meters/minute	264.1720	gallons (U.S.)/minute

① Where an asterisk is shown, the figure is exact.

Metric Conversion Factors Continued

MASS AND DENSITY		
MULTIPLY:	BY	TO OBTAIN:
grams	15.43236	grains
grams	0.001 ①	kilograms
grams/cubic centimeter	0.03612730	pounds/cubic inch
kilograms	1000 ①	grams
kilograms	35.27397	ounces
kilograms	32.15074	ounces (troy)
kilograms	2.204622	pounds
kilograms	0.06852178	slugs
kilograms	0.0009842	tons (long)
kilograms	0.0011023	tons (short)
kilograms	0.001 ①	tons (metric)
kilograms/cubic meter	0.06242797	pounds/cubic foot
kilograms/cubic meter	0.01002242	pounds/gallon (U.K.)
kilograms/cubic meter	0.008345406	pounds/gallon (U.S.)
ounces	28.34952	grams
ounces	0.02834952	kilograms
pounds	0.4535924	kilograms
pounds/cubic foot	16.01846	kilograms/cubic meter
pounds/cubic inch	27.67990	grams/cubic centimeter
pounds/gallon (U.S.)	119.8264	kilograms/cubic meter
pounds/gallon (U.K.)	99.77633	kilograms/cubic meter
slug	14.59390	kilograms
tons (long 2240 lbs)	1016.047	kilograms
tons (short 2000 lbs)	907.1847	kilograms
tons (metric)	1000. ①	kilograms

FORCE AND FORCE/LENGTH		
MULTIPLY:	BY	TO OBTAIN:
kilograms-force	9.806650 ①	newtons
newtons	0.1019716	kilograms-force
newtons	0.2248089	pounds-force
newtons/meter	0.00571015	pounds/inch
newtons/meter	0.06852178	pounds/foot
pounds-force	4.448222	newtons
pounds/inch	175.1268	newtons/meter
pounds/foot	14.59390	newtons/meter

BENDING MOMENT OR TORQUE		
MULTIPLY:	BY	TO OBTAIN:
kilogram-meters	9.806650 ①	newton-meters
ounce-inches	7.061552	newton-millimeters
ounce-inches	0.00706155	newton-meters
newton-meters	0.7375621	pound-feet
newton-meters	0.1019716	kilogram-meters
newton-meters	141.6119	ounce-inches
newton-millimeters	0.1416119	ounce-inches
pound-feet	1.355818	newton-meters

MOMENT OF INERTIA		
MULTIPLY:	BY	TO OBTAIN:
kilogram-meters squared	23.73036	pound-feet squared
kilogram-meters squared	3417.171	pound-inches squared
pound-feet squared	0.04214011	kilogram-meters squared
pound-inches squared	0.00029264	kilogram-meters squared

MOMENTUM		
MULTIPLY:	BY	TO OBTAIN:
kilogram-meters/second	7.233011	pound-feet/second
kilogram-meters/second	86.79614	pound-inches/second
pound-feet/second	0.1382550	kilogram-meters/second
pound-inches/second	0.01152125	kilogram-meters/second

PRESSURE AND STRESS		
MULTIPLY:	BY	TO OBTAIN:
bars	14.50377	pounds/square inch
kilograms/square centimeter	14.22334	pounds/square inch
kilograms/square meter	9.806650 ①	newtons/square meter
kilograms/square meter	0.2048161	pounds/square foot
newtons/square centimeter	1.450377	pounds/square inch
newtons/square meter	0.00014504	pounds/square inch
newtons/square meter	0.1019716	kilograms/square meter
pounds/cubic foot	4.882429	kilograms/square meter
pounds/cubic inch	0.07030697	kilograms/square centimeter
pounds/cubic inch	0.6894757	newtons/square centimeter
pounds/cubic inch	6.894757	kilonewtons/square meter
pounds/cubic inch	6894.757	newtons/square meter
pounds/cubic inch	0.00689476	newtons/square millimeter

ENERGY AND WORK		
MULTIPLY:	BY	TO OBTAIN:
Btu (mean)	1055.87	joule
calorie (mean)	4.19002	joule
foot-pound	1.355818	joule
joule	0.0009471	Btu (mean)
joule	0.2386623	calorie (mean)
joule	0.7375621	foot-pound
joule	0.999818	joule (International U.S.)
joule	0.999983	joule (U.S. legal, 1948)
joule (International U.S.)	1.000182	joule
joule (U.S. legal, 1948)	1.000017	joule
joule	0.00027778	watt-hour
watt-hour	3600. ①	joule

POWER		
MULTIPLY:	BY	TO OBTAIN:
Btu (International Table) hour	0.2930711	watt
foot-pound/hour	0.000376616	watt
foot-pound/minute	0.02259697	watt
horsepower (550 ft-lb/s)	0.7456999	kilowatt
horsepower (550 ft-lb/s)	745.6999	watt
horsepower (electric)	746 ①	watt
horsepower (metric)	735.499	watt
horsepower (U.K.)	745.7	watt
kilowatt	1.341022	horsepower (550 ft-lb/s)
watt	2655.224	foot-pound/hour
watt	44.25372	foot-pound/minute
watt	0.001341022	horsepower (550 ft-lb/s)
watt	0.001340483	horsepower (electric)
watt	0.001359621	horsepower (metric)
watt	0.001341022	horsepower (U.K.)
watt	3.412141	Btu (International Table)/hour

VISCOSITY		
MULTIPLY:	BY	TO OBTAIN:
centipoise	0.001 ①	pascal-second
centistoke	0.000001 ①	meters squared/second
meters squared/second	1,000,000	centistoke
meters squared/second	10,000. ①	stoke
pascal-second	1000. ①	centipoise
pascal-second	10. ①	poise
poise	0.1 ①	pascal-second
stoke	0.0001	meters squared/second

① Where an asterisk is shown, the figure is exact.

Standard Key and Setscrew Sizes

KEYSEATS AND KEYS

Drawings and formulas at right illustrate how the depth and width of standard keyseats in shafts and hubs are determined. Refer below to explanation of symbols.

SYMBOLS:

C = Allowance or clearance for key (normally 0.005" for parallel keys).

D = Nominal shaft or bore diameter (in)

H = Nominal key height (in)

W = Nominal key width (in)

Y = Chordal height (in)

$$Y = \frac{D - \sqrt{D^2 - W^2}}{2}$$

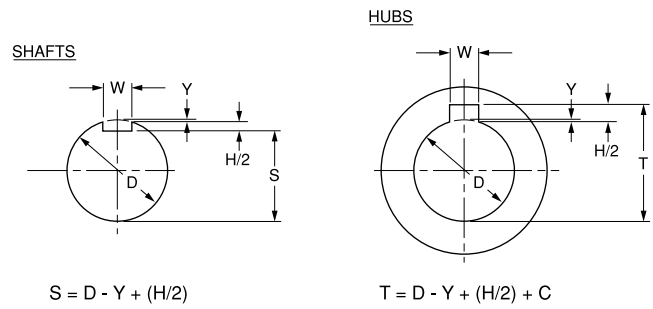

$$S = D - Y + (H/2)$$

$$T = D - Y + (H/2) + C$$

Shaft Diameters		Key W x H	Set Screw	Shaft Diameters		Key W x H	Set Screw	Shaft Diameters		Key W x H	Set Screw	Shaft Diameters		Key W x H
Over	Thru			Over	Thru			Over	Thru			Over	Thru	
7/16	9/16	1/8 x 1/8	#10	1-3/4	2-1/4	1/2 x 1/2	1/2	4-1/2	5-1/2	1-1/4 x 1-1/4	7/8	11	13	3 x 2
9/16	7/8	3/16 x 3/16	1/4	2-1/4	2-3/4	5/8 x 5/8	1/2	5-1/2	6-1/2	1-1/2 x 1-1/2	1	13	15	3-1/2 x 2-1/2
7/8	1-1/4	1/4 x 1/4	5/16	2-3/4	3-1/4	3/4 x 3/4	5/8	6-1/2	7-1/2	1-3/4 x 1-1/2	Ñ-	15	18	4 x 3
1-1/4	1-3/8	5/16 x 5/16	3/8	3-1/4	3-3/4	7/8 x 7/8	3/4	7-1/2	9	2 x 1-1/2	Ñ-	18	22	5 x 3-1/2
1-3/8	1-3/4	3/8 x 3/8	3/8	3-3/4	4-1/2	1 x 1	3/4	9	11	2-1/2 x 1-3/4	Ñ-	22	26	6 x 4

DIAMETERS AND AREAS OF UNIFIED SCREW THREADS UNC & UNF

Size Designation	Nominal Major Diameter (in)	Coarse Series — UNC			Fine Series — UNF		
		Threads per inch (N)	Tensile Stress Area (in ²)	Area of Minor Dia. (in ²)	Threads per inch (N)	Tensile Stress Area (in ²)	Area of Minor Dia. (in ²)
0	0.0600				80	0.00180	0.00151
1	0.0730	64	0.00263	0.00218	72	0.00278	0.00237
2	0.0860	56	0.00370	0.00310	64	0.00394	0.00339
3	0.0990	48	0.00487	0.00406	56	0.00523	0.00451
4	0.1120	40	0.00604	0.00496	48	0.00661	0.00566
5	0.1250	40	0.00796	0.00672	44	0.00830	0.00716
6	0.1380	32	0.00909	0.00745	40	0.01015	0.00874
8	0.1640	32	0.0140	0.01196	36	0.01474	0.01285
10	0.1900	24	0.0175	0.01450	32	0.0200	0.0175
12	0.2160	24	0.0242	0.0206	28	0.0258	0.0226
1/4	0.2500	20	0.0318	0.0269	28	0.0364	0.0326
5/16	0.3125	18	0.0524	0.0454	24	0.0580	0.0524
3/8	0.3750	16	0.0775	0.0678	24	0.0878	0.0809
7/16	0.4375	14	0.1063	0.0933	20	0.1187	0.1090
1/2	0.5000	13	0.1419	0.1257	20	0.1599	0.1486
9/16	0.5625	12	0.182	0.162	18	0.203	0.189
5/8	0.6250	11	0.226	0.202	18	0.256	0.240
3/4	0.7500	10	0.334	0.302	16	0.373	0.351
7/8	0.8750	9	0.462	0.419	14	0.509	0.480
1	1.0000	8	0.606	0.551	12	0.663	0.625
1-1/4	1.2500	7	0.969	0.890	12	1.073	1.024
1-1/2	1.5000	6	1.405	1.294	12	1.581	1.521

BOLT TORQUES

SAE DIA.	TORQUE REQUIREMENTS FOR DRY BLACK FASTENERS	
	GENERAL PURPOSE GRADE 2 TORQUE (lb-ft)	HIGH STRENGTH GRADE 5 TORQUE (lb-ft)
1/4	6	9
5/16	12	18
3/8	21	33
7/16	34	53
1/2	52	80
9/16	75	116
5/8	104	160
3/4	184	285
7/8	178	460
1	265	690
1-1/8	380	850
1-1/4	530	1200
1-3/8	700	1570
1-1/2	930	2080

- The torques shown produce a clamp load of 80% of proof load. They assume clean, dry threads with a torque coefficient of 0.2.
- Plated threads need only 3/4 torque shown.
- Well lubricated threads need only 1/2 torque shown.

ALL PLANETGEAR SPEED REDUCERS USE GRADE 5 FASTENERS.

Motor Operating Parameters and Formulas

NEMA STANDARDS

Electric motors are required to meet certain industrial safety and manufacturing standards. The accepted authority in the U.S.A. is the National Electrical Manufacturers Association — an organization that sets voluntary standards for acceptable practice for the motor industry. For example, they specify standard frame sizes, ratings, torque and horsepower classifications — as well as dimensions, performance, testing, etc.

MOTOR ELECTRICAL FORMULAS

TO FIND	Alternating Current		TO FIND	ALTERNATING OR DIRECT CURRENT
	Single-Phase	Three-Phase		
Amperes when Horsepower is known	$\frac{HP \times 746}{E \times \text{Eff} \times \text{pf}}$	$\frac{HP \times 746}{1.73 \times E \times \text{Eff} \times \text{pf}}$	Amperes when voltage and resistance are known:	E / R
Amperes when kilowatts are known	$\frac{KW \times 1,000}{E \times \text{pf}}$	$\frac{KW \times 1,000}{1.73 \times E \times \text{pf}}$	Voltage when resistance and current are known:	IR
Amperes when Kva are known	$\frac{Kva \times 1,000}{E}$	$\frac{Kva \times 1,000}{1.73 \times E}$	Resistance when voltage and current are known:	E / I
Kilowatts	$\frac{I \times E \times \text{pf}}{1,000}$	$\frac{1.73 \times I \times E \times \text{pf}}{1,000}$	I = Amperes E = Volts Eff = Efficiency pf = Power Factor KW = Kilowatts R = Ohms Kva = Kilovolt Amperes	
Kva	$\frac{I \times E}{1,000}$	$\frac{1.73 \times I \times E}{1,000}$	General Information (Approximation) All Voltages at 100% Load At 1,800 rpm, a motor develops a 36 lb-in per HP At 1,200 rpm, a motor develops a 54 lb-in per HP At 575 volts, a three-phase motor draws 1 amp per HP At 460 volts, a three-phase motor draws 1.25 amp per HP At 230 volts, a three-phase motor draws 2.5 amp per HP At 230 volts, a single-phase motor draws 5 amp per HP At 115 volts, a single-phase motor draws 10 amp per HP	
Horsepower = (Output)	$\frac{I \times E \times \text{Eff} \times \text{pf}}{746}$	$\frac{1.73 \times I \times E \times \text{Eff} \times \text{pf}}{746}$		
For variable descriptions, see chart at right.				

MOTOR AMPS AT FULL LOAD

HP	Alternating Current		DC	HP	Alternating Current		DC	HP	Alternating Current		DC	HP	Alternating Current		DC
	Single Phase	Three Phase			Single Phase	Three Phase			Single Phase	Three Phase			Single Phase	Three Phase	
1/2	4.9	2.0	2.7	5	28	14.4	20	25	—	60	92	75	—	180	268
1	8.0	3.4	4.8	7-1/2	40	21.0	29	30	—	75	110	100	—	240	355
1-1/2	10.0	4.8	6.6	10	50	26.0	38	40	—	100	146	125	—	300	443
2	12.0	6.2	8.5	15	—	38.0	56	50	—	120	180	150	—	360	534
3	17.0	8.6	12.5	20	—	50.0	74	60	—	150	215	200	—	480	712

Values are for all speeds and frequencies at 230 volts.

Amperage for other than 230 volts can be calculated as follows:

$$T = \frac{230 \times \text{Amps from Table}}{\text{New Voltage}}$$

Example: For 40 HP, three-phase at 550 volts

$$I = \frac{230 \times 100}{550} = 42 \text{ amps}$$

Power Factor estimated at 80% for most motors. Efficiency is usually 80-90%.

OBSELETE MOTOR SHAFT DIMENSIONS

Motor ratings and dimensions shown in the table below are the obsolete or 1953 NEMA "U" frame standards. These were replaced by the 1963 re-rating program which established the present "T" frames. In effect, a larger motor shaft and hp rating is obtained compared to the corresponding "U" frame sizes.

U-FRAME NEMA ASSIGNMENTS AND DIMENSIONS

Horsepower Ratings		U-Frame No.	U	Shaft Keyseat		Key Length	N-W	Horsepower Ratings		U-Frame No.	U	Shaft Keyseat		Key Length	N-W
1800	1200			Width	Depth			1800	1200			Width	Depth		
1	3/4	182	7/8	3/16	3/32	1-3/8	2-1/4	40	25	364U	2-1/8	1/2	1/4	5	6-3/8
1-1/2 & 2	1 & 1-1/2	184	7/8	3/16	3/32	1-3/8	2-1/4	—	—	364US	1-7/8	1/2	1/4	2	3-3/4
3	2	213	1-1/8	1/4	1/8	2	3	50	30	365U	2-1/8	1/2	1/4	5	6-3/8
5	3	215	1-1/8	1/4	1/8	2	3	—	—	365US	1-7/8	1/2	1/4	2	3-3/4
7-1/2	5	254U	1-3/8	1/4	1/8	2-3/4	3-3/4	60	40	404U	2-3/8	5/8	1/4	5-1/2	7-1/8
10	7-1/2	256U	1-3/8	1/4	1/8	2-3/4	3-3/4	—	—	404US	2-1/8	1/2	1/4	2-3/4	4-1/4
15	10	284U	1-5/8	3/8	3/16	3-3/4	4-7/8	75	50	405U	2-3/8	5/8	1/4	5-1/2	7-1/8
20	—	286U	1-5/8	3/8	3/16	3-3/4	4-7/8	—	—	405US	2-1/8	1/2	1/4	2-3/4	4-1/4
25	15	324U	1-7/8	1/2	1/4	4-1/4	5-5/8	100	60	444U	2-7/8	3/4	3/8	7	8-5/8
—	—	324S	1-5/8	3/8	3/16	1-7/8	3-1/4	—	—	444US	2-1/8	1/2	1/4	2-3/4	4-1/4
30	20	326U	1-7/8	1/2	1/4	4-1/4	5-5/8	125	75	445U	2-7/8	3/4	3/8	7	8-5/8
—	—	326S	1-5/8	3/8	3/16	1-7/8	3-1/4	—	—	445US	2-1/8	1/2	1/4	2-1/4	4-1/4

NEMA Electric T-Frame & TS-Frame Motor Dimensions

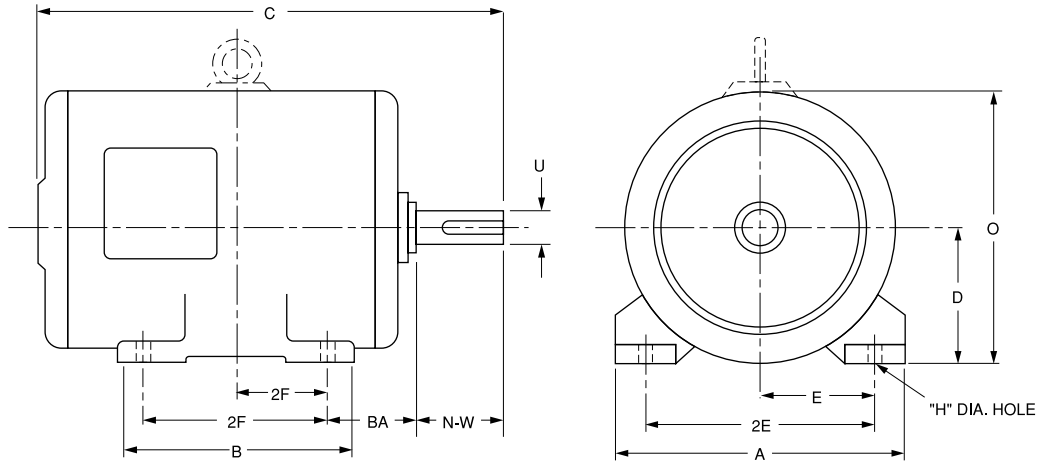

T-Frame & TS-Frame NEMA Assignments and Dimensions

Horsepower Ratings				T-Frame No.	U	Shaft Keyseat			N-W ^②	A Max.	B Max.	C ^①	D	E	F	H	BA	O ^①
TEFC	Open	Open & TEFC				Width	Depth	Key Length										
1800	1800	1200	900															
1	1	3/4	1/2	143T	0.875	0.19	0.09	1.38	2.25	7.00	6.00	12.63	3.50	2.75	2.00	0.34	2.25	7.00
1-1/2 & 2	1-1/2 & 2	1	3/4	145T	0.875	0.19	0.09	1.38	2.25	7.00	6.00	12.63	3.50	2.75	2.50	0.34	2.25	7.00
3	3	1-1/2	1	182T	1.125	0.25	0.13	1.75	2.75	9.00	6.50	12.75	4.50	3.75	2.25	0.41	2.75	9.00
5	5	2	1-1/2	184T	1.125	0.25	0.13	1.75	2.75	9.00	7.50	13.75	4.50	3.75	2.75	0.41	2.75	9.00
7-1/2	7-1/2	3	2	213T	1.375	0.31	0.16	2.38	3.38	10.50	7.50	15.81	5.25	4.25	2.75	0.41	3.50	10.50
10	10	5	3	215T	1.375	0.31	0.16	2.38	3.38	10.50	9.00	17.31	5.25	4.25	3.50	0.41	3.50	10.50
15	15	7-1/2	5	254T	1.625	0.38	0.19	2.88	4.00	12.50	10.75	20.50	6.25	5.00	4.13	0.53	4.25	12.50
20	20	10	7-1/2	256T	1.625	0.38	0.19	2.88	4.00	12.50	12.50	22.25	6.25	5.00	5.00	0.53	4.25	12.50
25	25	15	10	284T	1.875	0.50	0.25	3.25	4.63	14.00	12.50	23.31	7.00	5.50	4.75	0.53	4.75	14.00
25	25	15	10	284TS	1.625	0.38	0.19	1.88	3.25	14.00	12.50	22.00	7.00	5.50	4.75	0.53	4.75	14.00
30	30	20	15	286T	1.875	0.50	0.25	3.25	4.63	14.00	14.00	24.88	7.00	5.50	5.50	0.53	4.75	14.00
30	30	20	15	286TS	1.625	0.38	0.19	1.88	3.25	14.00	14.00	23.50	7.00	5.50	5.50	0.53	4.75	14.00
40	40	25	20	324T	2.125	0.50	0.25	3.88	5.25	16.00	14.00	26.50	8.00	6.25	5.25	0.66	5.25	16.00
40	40	25	20	324TS	1.875	0.50	0.25	2.00	3.75	16.00	14.00	24.63	8.00	6.25	5.25	0.66	5.25	16.00
50	50	30	25	326T	2.125	0.50	0.25	3.88	5.25	16.00	15.50	27.75	8.00	6.25	6.00	0.66	5.25	16.00
50	50	30	25	326TS	1.875	0.50	0.25	2.00	3.75	16.00	15.50	26.13	8.00	6.25	6.00	0.66	5.25	16.00
60	60	40	30	364T	2.375	0.63	0.31	4.25	5.88	18.00	15.25	28.75	9.00	7.00	5.63	0.66	5.88	18.00
60	60	40	30	364TS	1.875	0.50	0.25	2.00	3.75	18.00	15.25	26.56	9.00	7.00	5.63	0.66	5.88	18.00
75	75	50	40	365T	2.375	0.63	0.31	4.25	5.88	18.00	16.25	29.75	9.00	7.00	6.13	0.66	5.88	18.00
75	75	50	40	365TS	1.875	0.50	0.25	2.00	3.75	18.00	16.25	27.56	9.00	7.00	6.13	0.66	5.88	18.00
—	100	60	50	404T	2.875	0.75	0.38	5.63	7.25	20.00	16.25	32.63	10.00	8.00	6.13	0.81	6.63	20.00
—	100	60	50	404TS	2.125	0.50	0.25	2.75	4.25	20.00	16.25	29.63	10.00	8.00	6.13	0.81	6.63	20.00
100	125	75	60	405T	2.875	0.75	0.38	5.63	7.25	20.00	17.75	34.13	10.00	8.00	6.88	0.81	6.63	20.00
100	125	75	60	405TS	2.125	0.50	0.25	2.75	4.25	20.00	17.75	31.13	10.00	8.00	6.88	0.81	6.63	20.00
125	150	100	75	444T	3.375	0.88	0.44	6.88	8.50	22.00	18.50	37.88	11.00	9.00	7.25	0.81	7.50	22.00
125	150	100	75	444TS	2.375	0.63	0.31	3.00	4.75	22.00	18.50	34.13	11.00	9.00	7.25	0.81	7.50	22.00
150	200	125	100	445T	3.375	0.88	0.44	6.88	8.50	22.00	20.50	39.88	11.00	9.00	8.25	0.81	7.50	22.00
150	200	125	100	445TS	2.375	0.63	0.31	3.00	4.75	22.00	20.50	36.13	11.00	9.00	8.25	0.81	7.50	22.00
—	—	—	—	447T	3.375	0.88	0.44	6.88	8.50	22.00	23.00	43.25	11.00	9.00	10.00	0.81	7.50	22.00
—	—	—	—	447TS	2.375	0.63	0.31	3.00	4.75	22.00	23.00	39.50	11.00	9.00	10.00	0.81	7.50	22.00
—	—	—	—	449T	3.375	0.88	0.44	6.88	8.50	22.00	28.00	48.25	11.00	9.00	12.50	0.81	7.50	22.00
—	—	—	—	449TS	2.375	0.63	0.31	3.00	4.75	22.00	28.00	44.50	11.00	9.00	12.50	0.81	7.50	22.00

NOTE: Suffix “S” indicates short shaft for direct coupled service only. Motors of 25 HP and up listed as T-Frame may also be available in TS-Frames.

- ① These dimensions are not NEMA standard, but they are average and common to a number of manufactures for Open (Drip Proof) motors. TEFC motors will be up to 5 inches longer, and may be slightly taller (less than an inch difference).
- ② Usable length of shaft “V” is 1/4 inch shorter than “N-W”.

NEMA Electric TC-Frame Motor Dimensions

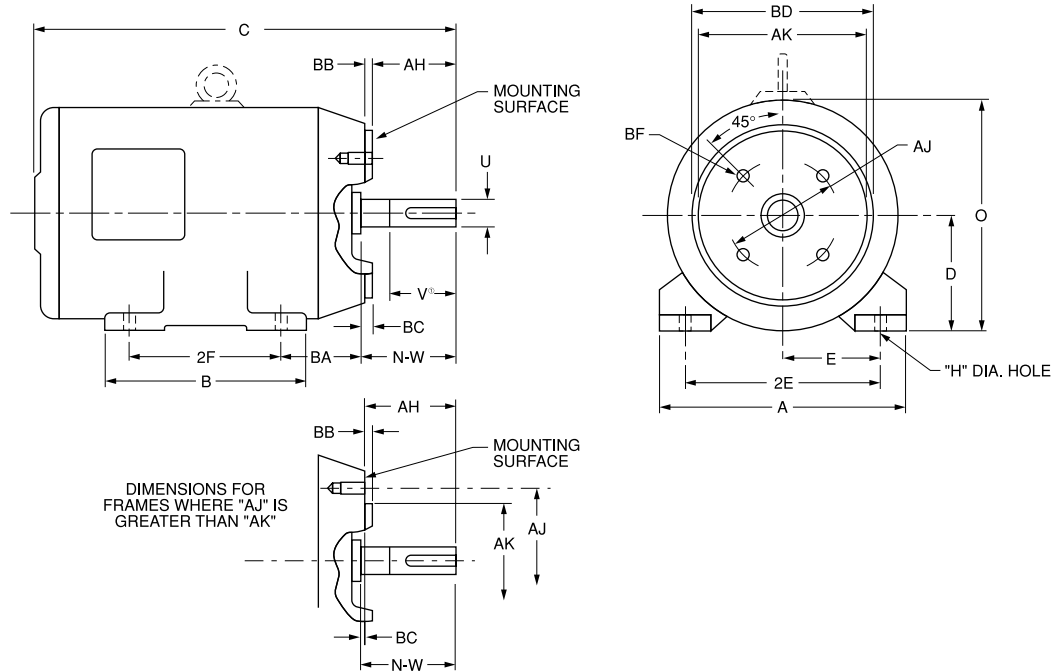

TC-Frame NEMA Assignments and Dimensions ②

Frame No.	AJ	AK	BA	BB min.	BC	BD max.	BF (hole)			AH	U	Shaft Keyseat		Key Length
							Number of Holes	Tap Size	Bolt Penetration Allowance			Width	Depth	
56C	5.875	4.500	2.75	0.16	-0.19	6.50	4	3/8-16	N-	2.06	0.625	0.19	0.09	1.38
143TC and 145TC	5.875	4.500	2.75	0.16	0.12	6.50	4	3/8-16	0.56	2.12	0.875	0.19	0.09	1.38
182TC and 184TC	7.250	8.500	3.50	0.25	0.12	9.00	4	1/2-13	0.75	2.62	1.125	0.25	0.13	1.75
182TCH and 184TCH	5.875	4.500	3.50	0.16	0.12	6.50	4	3/8-16	0.56	2.62	1.125	0.25	0.13	1.75
213TC and 215TC	7.250	8.500	4.25	0.25	0.25	9.00	4	1/2-13	0.75	3.12	1.375	0.31	0.16	2.38
254TC and 256TC	7.250	8.500	4.75	0.25	0.25	10.00	4	1/2-13	0.75	3.75	1.625	0.38	0.19	2.88
284TC and 286TC	9.000	10.500	4.75	0.25	0.25	11.25	4	1/2-13	0.75	4.38	1.875	0.50	0.25	3.25
284TSC and 286TSC	9.000	10.500	4.75	0.25	0.25	11.25	4	1/2-13	0.75	3.00	1.625	0.38	0.19	1.88
324TC and 326TC	11.000	12.500	5.25	0.25	0.25	14.00	4	5/8-11	0.94	5.00	2.125	0.50	0.25	3.88
324TSC and 326TSC	11.000	12.500	5.25	0.25	0.25	14.00	4	5/8-11	0.94	3.50	1.875	0.50	0.25	2.00
364TC and 365TC	11.000	12.500	5.88	0.25	0.25	14.00	8	5/8-11	0.94	5.62	2.375	0.63	0.31	4.25
364TSC and 365TSC	11.000	12.500	5.88	0.25	0.25	14.00	8	5/8-11	0.94	3.50	1.875	0.50	0.25	2.00
404TC and 405TC	11.000	12.500	6.62	0.25	0.25	15.50	8	5/8-11	0.94	7.00	2.875	0.75	0.38	5.63
404TSC and 405TSC	11.000	12.500	6.62	0.25	0.25	15.50	8	5/8-11	0.94	4.00	2.125	0.50	0.25	2.75
444TC and 445TC	14.000	16.000	7.50	0.25	0.25	18.00	8	5/8-11	0.94	8.25	3.375	0.88	0.44	6.88
444TSC and 445TSC	14.000	16.000	7.50	0.25	0.25	18.00	8	5/8-11	0.94	4.50	2.375	0.63	0.31	3.00

① Usable length of shaft "V" is 1/4 inch shorter than "N-W".
 ② Refer to T-Frame chart (page 81) for dimensions not listed.

IEC Electric Motor Dimensions

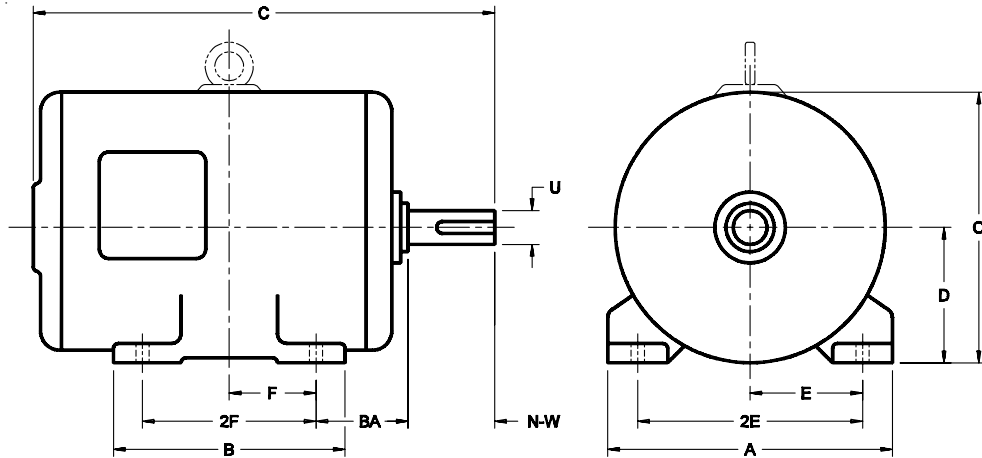

IEC STANDARDS

Many countries have adopted IEC Standards, IEC stands for “The International Electrotechnical Commission”. The object of the commission is to facilitate the coordination and unification of National Electrotechnical Standards.

IEC motors are in service worldwide. The standards have been incorporated into individual national standards. Outputs are in KW and dimensions are in millimeters. Table below shows the common IEC frame sizes of one motor manufacturer.

Mechanically, the major mounting dimensions of NEMA vs IEC are similar. Each standard has adopted units of dimensions predominant within the country it's used in.

IEC THREE-PHASE MOTORS WITH SQUIRREL CAGE ROTOR

KW Rating				IEC Frame No. ①			N - W (mm)	E (mm)	F (mm)	BA (mm)
RPM				D (mm)	C	U (mm)				
3000	1500	1000	750							
0.75	—	0.25, 0.37	—	80	—	19	40	63	50	50
1.5	1.1	0.75	—	90	S	24	50	70	50	56
2.2	1.5	1.1	—	90	L	24	50	70	62	56
3	2.2, 3	1.5	0.75, 1.1	100	L	28	60	80	70	63
4	4	2.2	1.5	112	M	28	60	95	70	70
5.5, 7.5	5.5	3	2.2	132	S	38	80	108	70	89
—	7.5	4, 5.5	3	132	M	38	80	108	89	89
11, 15	11	7.5	4, 5.5	160	M	42	110	127	105	108
18.5	15	11	7.5	160	L	42	110	127	127	108
22	18.5	—	—	180	M	48	110	140	120	121
—	22	15	11	180	L	48	110	140	140	121
30, 37	30	18.5, 22	15	200	L	55	110	159	152	133
—	37	—	18.5	225	S	60	140	178	143	149
45	—	—	—	225	M	55	110	178	156	149
—	45	30	22	225	M	60	140	178	156	149
55	—	—	—	250	M	60	140	203	174	168
—	55	37	30	250	M	65	140	203	174	168
75	—	—	—	280	S	65	140	229	184	190
—	75	45	37	280	S	75	140	229	184	190
90	—	—	—	280	M	65	140	229	210	190
—	90	55	45	280	M	75	140	229	210	190
110	—	—	—	315	S	65	140	254	203	216
—	110	75	55	315	S	80	170	254	203	216
132	—	—	—	315	M	65	140	254	228	216
—	132	90	75	315	M	80	170	254	228	216

KEY SIZES

Shaft Size Dia. U ② (mm)	Shaft Length (N-W) ② (mm)	Key Size (Square: W, H) (mm)
7	16	2
9	20	3
11	23	4
14	30	5
16	40	5
18	40	6
19	40	6
22	50	6
24	50	8
28	60	8
32	80	10
38	80	10
42	110	12
48	110	14
55	110	16
60	140	18
65	140	18
70	140	20
75	140	20
80	170	22
85	170	22
90	170	25
95	170	25
100	210	28
110	210	28

② From motor sketch.

① IEC frame sizes are made up of shaft height (mm), length (letter) and shaft diameter (mm), for example 90S-24. Three frame lengths may be offered, S = Short, M = Medium, L = Long.

Dimensional Information and Nominal Ratio Listing

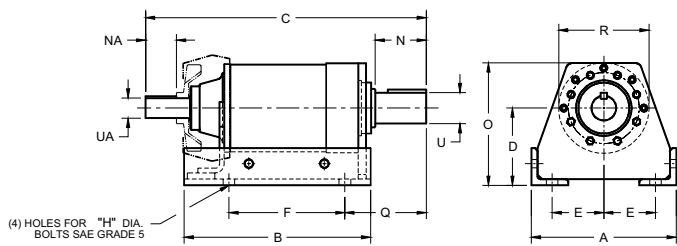

MERCURY AND MARS

Nominal Ratios Available ① with Corresponding Output Torque Range

Nominal Ratio	Maximum Output Torque (lb-in)
3.53	117,000
4.39	144,000
6.12	150,000
9.30	64,000
11.02	405,000
13.85	555,000
17.21	592,000
20.41	610,000
24.00	522,000
31.63	512,000
36.56	580,000
43.78	794,000
54.45	800,000
64.42	807,000
69.63	811,000
80.01	703,000
91.41	819,000
99.38	551,000
111.5	712,000
121.4	825,000
138.5	831,000
159.8	724,000
193.1	564,000
206.2	730,000
238.2	849,000
265.4	852,000
295.7	856,000
330.1	858,000
369.8	863,000
412.1	865,000
459.0	869,000
532.5	874,000
617.9	761,000
660.6	763,000
741.2	885,000
900.3	892,000
1057	899,000
1255	903,000
1785	905,000

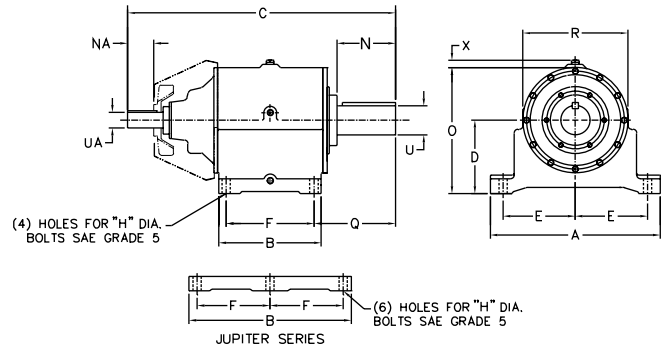

VENUS, ATLAS, LUNA, EARTH, POLARIS, DELTA, NEPTUNE PLUS, ORION PLUS, SATURN PLUS, TITAN PLUS AND JUPITER PLUS

Series	A	B	C ②			D	E	F	H bolt	O	Q	R
			s,d	t	quad							
Mercury	11.75	15.13	19.88	22.13	24.38	6.25	4.19	9.41	7/8	9.91	6.59	7.32
Mars	11.75	15.13	21.25	23.50	25.75	6.25	4.19	9.41	7/8	9.91	7.46	7.32
Venus	18.00	11.75	29.73	29.73	28.52	7.75	8.00	9.53	1	13.50	8.63	11.50
Atlas	18.00	11.75	30.73	30.73	29.52	7.75	8.00	9.53	1	13.50	9.63	11.50
Luna	18.00	11.75	30.73	30.73	29.52	7.75	8.00	9.53	1	13.50	9.63	11.50
Earth	23.25	11.75	34.08	34.08	35.71	8.75	9.88	9.53	1	15.94	11.38	14.38
Polaris	23.25	14.00	36.30	36.30	37.92	10.00	9.88	11.75	1	17.19	11.29	14.38
Delta	23.25	14.00	36.30	36.30	37.92	10.00	9.88	11.75	1	17.19	11.29	14.38
Neptune	29.25	11.69	42.80	42.80	42.69	11.25	12.88	8.19	1-1/4	20.94	18.83	19.38
Neptune Plus	29.25	11.69	42.80	42.80	42.69	11.25	12.88	8.19	1-1/4	20.94	18.83	19.38
Orion Plus	29.25	19.62	46.21	46.21	46.11	11.25	12.88	16.00	1-1/4	20.94	14.37	19.38
Saturn Plus	33.25	19.86	51.78	51.78	54.25	12.88	14.63	11.00	1-1/2	24.25	22.04	22.75
Titan Plus	33.25	19.86	51.78	51.78	54.25	12.88	14.63	16.00	1-1/2	24.25	18.74	22.75
Jupiter Plus	33.25	28.88	62.94	62.94	62.94	16.50	14.63	12.50	1-1/2	31.50	20.88	30.00

Series	X	Low Speed Shaft		High Speed Shaft				UA		Avg. Wt. Lbs.
		N	U	NA		UA				
				w/o fan	w/ fan	s,d,t	quad			
Mercury	—	4.15	2.000	3.00	3.00	1.88	1.88	1.375	1.375	144
Mars	—	4.98	2.500	3.50	3.50	2.38	2.38	1.625	1.625	150
Venus	1.00	5.50	2.750	4.25	3.50	2.88	2.50	1.875	1.625	295
Atlas	1.00	6.50	3.250	4.25	3.50	2.88	2.50	1.875	1.625	325
Luna	1.00	6.50	3.250	4.25	3.50	2.88	2.50	1.875	1.625	325
Earth	1.00	7.00	3.500	4.50	4.25	3.25	2.88	2.125	1.875	481
Polaris	1.00	8.00	4.000	4.50	4.25	2.88	2.88	2.125	1.875	702
Delta	1.00	8.00	4.000	4.50	4.25	2.88	2.88	2.125	1.875	702
Neptune	1.00	9.00	4.500	5.68	4.50	3.56	3.25	2.500	2.125	923
Neptune Plus	1.00	9.00	4.500	5.68	4.50	3.56	3.25	2.500	2.125	923
Orion Plus	1.00	10.00	5.000	5.68	4.50	3.56	3.25	2.500	2.125	1146
Saturn Plus	1.00	11.25	6.500	6.50	5.68	4.38	3.56	3.000	2.500	2000
Titan Plus	1.00	11.25	6.500	6.50	5.68	4.38	3.56	3.000	2.500	2000
Jupiter Plus	3.50	12.25	7.250	6.50	6.50	4.38	4.38	3.000	3.000	3470

- SEE Table 12 to Table 19, pages 46-53 -

① Ratios listed may not be available in all speed reducer series.

② Mercury and Mars: Add 0.66 in. with backstop.
 Venus Quad: Add 0.66 in. with backstop.
 Atlas Quad: Add 0.66 in. with backstop.



866-REXNORD/866-739-6673 (Within the US)
414-643-2366 (Outside the US)
www.rexnord.com

Why Choose Rexnord?

When it comes to providing highly engineered products that improve productivity and efficiency for industrial applications worldwide, Rexnord is the most reliable in the industry. Commitment to customer satisfaction and superior value extend across every business function.

Delivering Lowest Total Cost of Ownership

The highest quality products are designed to help prevent equipment downtime and increase productivity and dependable operation.

Valuable Expertise

An extensive product offering is accompanied by global sales specialists, customer service and maintenance support teams, available anytime.

Solutions to Enhance Ease of Doing Business

Commitment to operational excellence ensures the right products at the right place at the right time.

Rexnord Corporation

Rexnord is a growth-oriented, multi-platform industrial company with leading market shares and highly trusted brands that serve a diverse array of global end markets.

Process and Motion Control

The Rexnord Process and Motion Control platform designs, manufactures, markets and services specified, highly engineered mechanical components used within complex systems where our customers' reliability requirements and the cost of failure or downtime are extremely high.

Water Management

The Rexnord Water Management platform designs, procures, manufactures and markets products that provide and enhance water quality, safety, flow control and conservation.

REXNORD

Rex **FALK** **Link-Belt** **mar/bett** **MCC** **BERG** **highfield** **Stearns**